



V961PBC Rev. B1

LOCAL BUS TO PCI BRIDGE
FOR i960®Jx AND PowerPC™ 401Gx
PROCESSORS

- Glueless interface between i960Jx, PPC401Gx processors and the PCI bus
- Large, 576-byte FIFOs using V3's unique *DYNAMIC BANDWIDTH ALLOCATION™* architecture
- Up to 33MHz PCI bus operation, independent of local processor speed
- Configurable for PCI system master, bus master, or target modes
- Bi-Directional address space remapping
- On-the-fly byte order (endian) conversion
- 2 channel DMA controller
- Bi-directional mailboxes w/doorbell interrupts
- Support for real-mode DOS configuration
- Flexible PCI and local interrupt management
- Serial EEPROM configuration interface
- Fully compliant with PCI 2.1 specification
- Available in 33 and 40MHz versions
- Low cost 160-pin EIAJ PQFP package

The V961PBC provides the highest performance, most flexible, and most economical method to connect i960Jx or PPC401Gx processors to the PCI bus. V3 Semiconductor's "no glue logic" approach makes the V961PBC the fastest route to adding PCI to your i960Jx or PPC401Gx system. The V961PBC may also be used in systems without a CPU for a generic PCI master/target interface.

The V961PBC supports independent interface speeds allowing the PCI bus to run at the full 33MHz frequency, regardless of processor clock rate. The V961PBC uses the unique *DYNAMIC BANDWIDTH ALLOCATION™* FIFOs to decouple the processor and PCI bus, while dramatically improving the overall throughput of the system.

The i960Jx processor gains access to the PCI bus through two programmable address apertures. Two more apertures are provided for PCI-to-local bus accesses. The V961PBC also includes bi-directional address remapping capabilities, and on-the-fly byte order conversion.

Two DMA channels are provided for autonomous PCI-to-Local/Local-to-PCI transfers. Mailbox registers are also included to provide a simple mechanism to emulate PCI device control ports. The V961PBC's PCI interrupt control mechanism is the most flexible of any bridge on the market.

The V961PBC operates up to 40MHz, and is packaged in a low cost, 160-pin EIAJ Plastic Quad Flat Pack (PQFP) package.

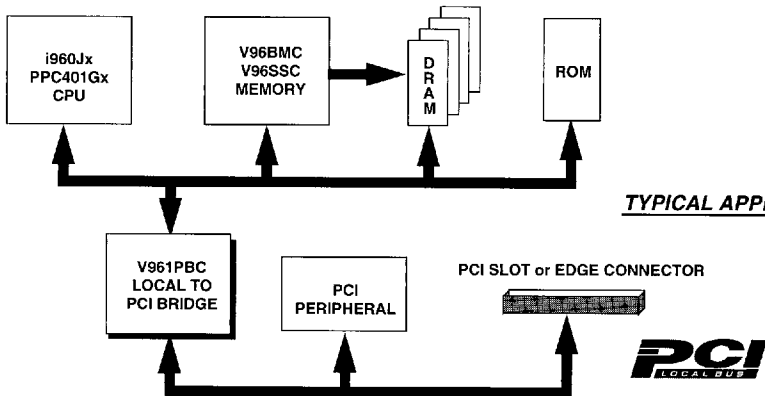

V961PBC

This document contains the product codes, pinouts, package mechanical information, DC characteristics, and AC characteristics for the V961PBC. Detailed functional information is contained in the User's Manual.

V3 Semiconductor retains the rights to change documentation, specifications, or device functionality at any time without notice. Please verify that you have the latest copy of all documents before finalizing a design.

1.0 Product Codes

Table 1: Product Codes

Product Code	Processor	Bus Type	Package	Frequency
V961PBC-33LP	i960JA/JD/JF PPC401GF	32-bit multiplexed	160-pin EIAJ PQFP	33MHz
V961PBC-40LP	i960JA/JD/JF PPC401GF	32-bit multiplexed	160-pin EIAJ PQFP	40MHz

2.0 Pin Description and Pinout

Table 2 below lists the pin types found on the V961PBC. Table 3 describes the function of each pin on the V961PBC. Table 5 lists the pins by pin number. Figure 1 shows the pinout for the 160-pin EIAJ PQFP package and Figure 2 shows the mechanical dimensions of the package.

Table 2: Pin Types

Pin Type	Description
PCI I	PCI input only pin.
PCI O	PCI output only pin.
PCI I/O	PCI tri-state I/O pin.
PCI I/OD	PCI input with open drain output.
I/O ₄	TTL I/O pin with 4mA output drive.
I	TTL input only pin.
O ₄	TTL output pin with 4mA output drive.

Table 3: Signal Descriptions

PCI Bus Interface			
Signal	Type	R ^a	Description
AD[31:0]	PCI I/O	Z	Address and data, multiplexed on the same pins.
C/BE[3:0]	PCI I/O	Z	Bus Command and Byte Enables, multiplexed on the same pins.
PAR	PCI I/O	Z	Parity represents even parity across AD[31:0] and C/BE[3:0].
FRAME	PCI I/O	Z	Cycle Frame indicates the beginning and burst length of an access.
IRDY	PCI I/O	Z	Initiator Ready indicates the initiating agent's (bus master's) ability to complete the current data phase of the transaction.
TRDY	PCI I/O	Z	Target Ready indicates the target agent's (selected device's) ability to complete the current data phase of the transaction.
STOP	PCI I/O	Z	Stop indicates the current target is requesting the master to stop the current transaction (retry or disconnect).
DEVSEL	PCI I/O	Z	Device Select, when actively driven by a target, indicates the driving device has decoded its address as the target of the current access. As an input to the initiator, DEVSEL indicates whether any device on the bus has been selected.
IDSEL	PCI I		Initialization Device Select is used as a chip select during configuration read and write transactions. It must be driven high in order to access the chip's internal configuration space.
REQ	PCI O	H	Request indicates to the arbiter that this agent requests use of the bus.
GNT	PCI I		Grant indicates to the agent that access to the bus has been granted.
PCLK	PCI I		PCLK provides timing for all transactions on the PCI bus.
PRST	PCI I/O	Z/L	Acts as an input when RDIR is high, an output when RDIR is low. As an input it is asserted low to bring all internal PBC operation to a reset state.
PERR	PCI I/O	Z	Parity Error is used to report data parity errors during all PCI transactions except a Special Cycle.
SERR	PCI I/OD	Z	System Error is used to report address parity errors, data parity errors on the Special Cycle command, or any other system error where the result will be catastrophic.
INT[A:D]	PCI I/OD	Z	Level-sensitive interrupt requests may be received or generated.

Table 3: Signal Descriptions (cont'd)

Local Bus Interface			
Signal	Type	R	Description
LAD[31:0]	I/O4	Z	Local multiplexed address and data bus.
LA[5:2]	I/O4	Z	Local address bus.
$\overline{\text{BE}}[3:0]$	I/O4	Z	Local bus byte enables.
W/ $\overline{\text{R}}$	I/O4	Z	Write/Read.
ALE	I/O4	Z	Address Latch Enable: used to latch the address during the address phase.
$\overline{\text{ADS}}$	I/O4	Z	Asserted low to indicate the beginning of a bus cycle.
$\overline{\text{RDYRCV}}$	I/O4	Z	Local Bus data ready.
HOLD	O4	L	Local bus hold request: asserted by the chip to initiate a local bus master cycle.
HOLDA	I		Local bus hold acknowledge.
LPAR[3:0]	I/O4	Z	Local bus parity.
$\overline{\text{BLAST}}$	I/O4	Z	Burst last.
$\overline{\text{BTERM}}$	I/O4	Z	Bus Time-out. Burst terminate.
LINT	O4	H	Local interrupt request.
$\overline{\text{LRST}}$	I/O4	L/Z	Local bus RESET signal.
LCLK	I		Local bus clock.

Serial EEPROM Interface			
Signal	Type	R	Description
SCL/ $\overline{\text{LPERR}}$	O4	X	EEPROM clock. Local parity error.
SDA	I/O4	X	EEPROM data.

Configuration			
Signal	Type	R	Description
RDIR	I		Reset direction. Tie low to drive $\overline{\text{PRST}}$ out and $\overline{\text{LRST}}$ in, high to drive $\overline{\text{LRST}}$ out and $\overline{\text{PRST}}$ in.

Table 3: Signal Descriptions (cont'd)

Power and Ground Signals			
Signal	Type	R	Description
V _{CC}	-		POWER leads intended for external connection to a V _{CC} board plane.
GND	-		GROUND leads intended for external connection to a GND board plane.

a. R indicates state during reset.

2.1 Test Mode Pins

Several device pins are used during manufacturing test to put the V961PBC device into various test modes. **These pins must be maintained at proper levels during reset to insure proper operation.** This is typically handled through pull-up or pull-down resistors (typically 1K to 10K) on the signal pins if they are not guaranteed to be at the proper level during reset. Table 4 below shows the reset states for test mode pins:

Table 4: RESET State for Test Mode Pins

PIN#	134	135	153
Connection	Pull-Down	Pull-Up	Pull-Down

Table 5: Pin Assignments

PIN #	Signal	PIN #	Signal	PIN #	Signal	PIN #	Signal
1	V _{CC}	41	V _{CC}	81	V _{CC}	121	V _{CC}
2	INTD	42	AD14	82	NC	122	NC
3	PRST	43	AD13	83	LAD8	123	LAD25
4	PCLK	44	AD12	84	NC	124	LA5
5	GNT	45	AD11	85	LAD9	125	LAD26
6	REQ	46	AD10	86	NC	126	LA4
7	AD31	47	AD9	87	LAD10	127	LAD27
8	AD30	48	AD8	88	NC	128	LA3

Table 5: Pin Assignments (cont'd)

PIN #	Signal	PIN #	Signal	PIN #	Signal	PIN #	Signal
9	AD29	49	C/BE $\overline{0}$	89	LAD11	129	LAD28
10	AD28	50	V _{CC}	90	NC	130	LA2
11	GND	51	GND	91	LAD12	131	LAD29
12	AD27	52	AD7	92	NC	132	LAD30
13	AD26	53	AD6	93	LAD13	133	LAD31
14	AD25	54	AD5	94	NC	134	ALE
15	AD24	55	AD4	95	LAD14	135	BTERM
16	C/BE $\overline{3}$	56	AD3	96	NC	136	RDYRCV
17	IDSEL	57	AD2	97	LAD15	137	HOLD
18	AD23	58	AD1	98	NC	138	HOLDA
19	AD22	59	AD0	99	LAD16	139	ADS
20	V _{CC}	60	V _{CC}	100	V _{CC}	140	V _{CC}
21	GND	61	GND	101	GND	141	GND
22	AD21	62	LAD0	102	NC	142	LCLK
23	AD20	63	NC	103	LAD17	143	GND
24	AD19	64	LAD1	104	NC	144	V _{CC}
25	AD18	65	NC	105	LAD18	145	BE $\overline{3}$
26	AD17	66	LAD2	106	NC	146	BE $\overline{2}$
27	AD16	67	NC	107	LAD19	147	BE $\overline{1}$
28	C/BE $\overline{2}$	68	LAD3	108	NC	148	BE $\overline{0}$
29	FRAME	69	NC	109	LAD20	149	BLAST
30	GND	70	LAD4	110	NC	150	W/R
31	IRDY	71	NC	111	LAD21	151	RDIR
32	TRDY	72	LAD5	112	NC	152	LRST
33	DEVSEL	73	NC	113	LAD22	153	'0'
34	STOP	74	LAD6	114	NC	154	LINT
35	PERR	75	NC	115	LAD23	155	SDA

Table 5: Pin Assignments (cont'd)

PIN #	Signal	PIN #	Signal	PIN #	Signal	PIN #	Signal
36	$\overline{\text{SERR}}$	76	LAD7	116	NC	156	$\text{SCL}/\overline{\text{LPERR}}$
37	PAR	77	NC	117	LPAR2	157	$\overline{\text{INTA}}$
38	$\text{C}/\overline{\text{BET}}$	78	LPAR0	118	LPAR3	158	$\overline{\text{INTB}}$
39	AD15	79	LPAR1	119	LAD24	159	$\overline{\text{INTC}}$
40	GND	80	GND	120	GND	160	GND

Figure 1: Pinout for 160-pin EIAJ PQFP (top view)

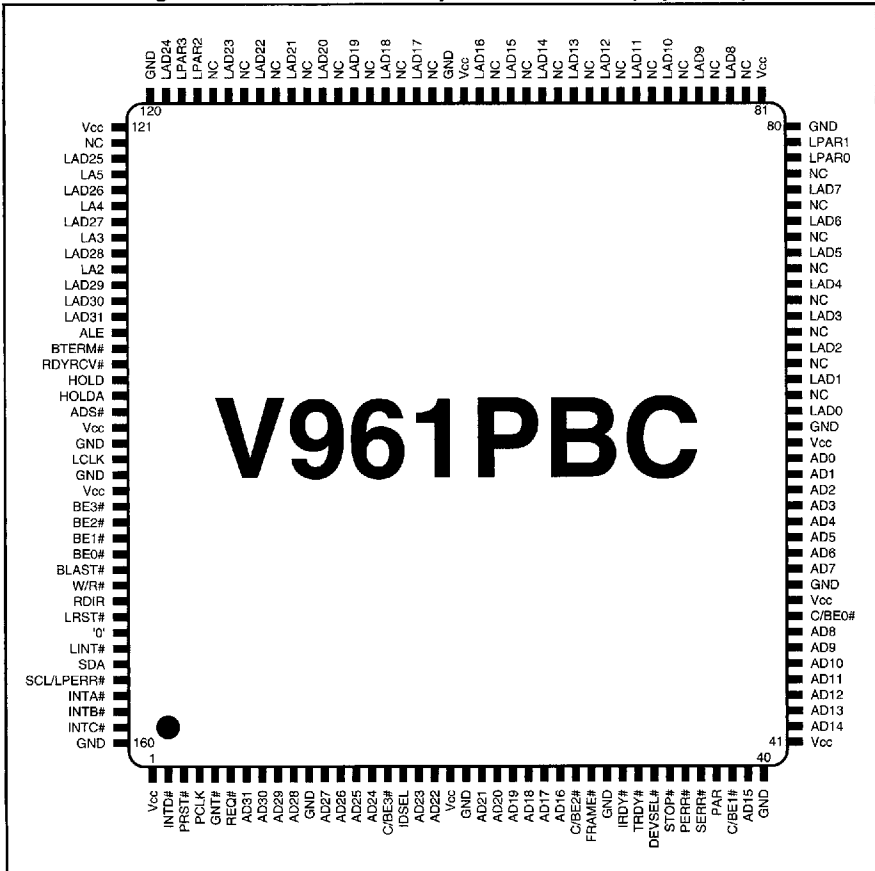
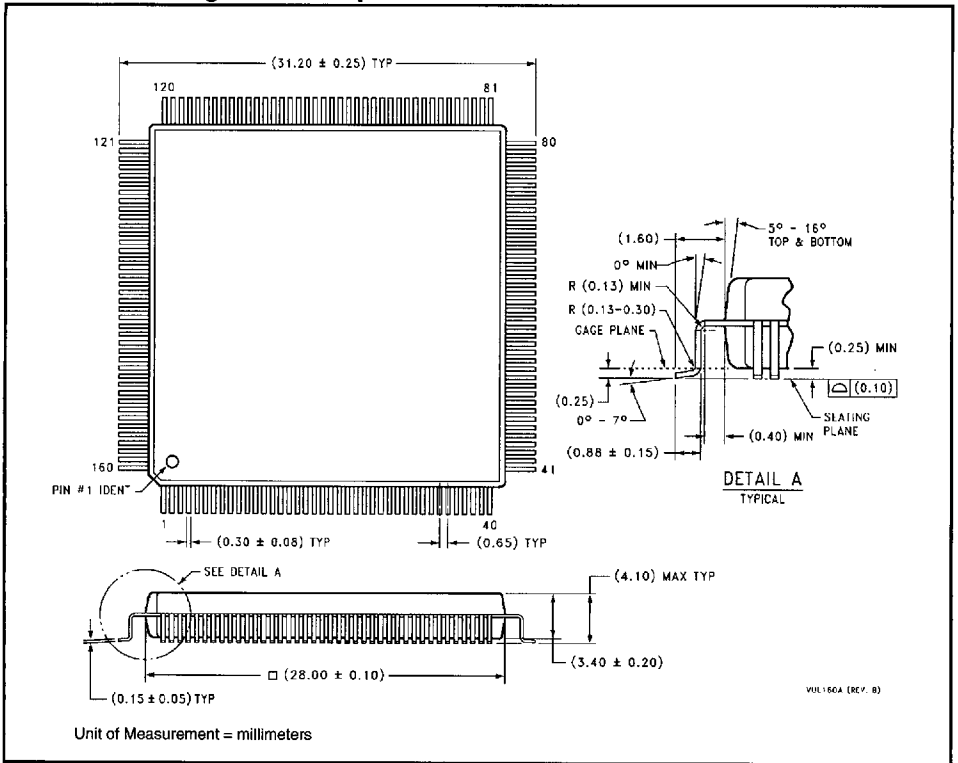

Figure 2: 160-pin EIAJ PQFP mechanical details



3.0 DC Specifications

The DC specifications for the PCI bus signals match exactly those given in the PCI Specification, Rev. 2.1, Section 4.2.1.1. For more information on the PCI DC specifications, see the PCI Specification.

Table 6: Absolute Maximum Ratings

Symbol	Parameter	Value	Units
V_{CC}	Supply voltage	-0.3 to +7	V
V_{IN}	DC input voltage	-0.3 to $V_{CC}+0.3$	V
I_{IN}	DC input current	± 10	mA
T_{STG}	Storage temperature range	-40 to +125	$^{\circ}C$

8

Table 7: Guaranteed Operating Conditions

Symbol	Parameter	Value	Units
V_{CC}	Supply voltage	4.75 to 5.25	V
T_A	Ambient temperature range	0 to 70	$^{\circ}C$

3.1 PCI Bus DC Specifications

Table 8: PCI Bus Signals DC Operating Specifications

Symbol	Parameter	Condition	Min	Max	Units	Notes
V_{IH}	Input high voltage		2.0	$V_{CC}+0.5$	V	
V_{IL}	Input low voltage		-0.5	0.8	V	
I_{IH}	Input high leakage current	$V_{IN} = 2.7V$		70	μA	1
I_{IL}	Input low leakage current	$V_{IN} = 0.5V$		-70	μA	1
V_{OH}	Output high voltage	$I_{OUT} = -2mA$	2.4		V	
V_{OL}	Output low voltage	$I_{OUT} = 3mA, 6mA$		0.55	V	2
C_{IN}	Input pin capacitance			10	pF	3
C_{CLK}	PCLK pin capacitance		5	12	pF	
C_{IDSEL}	IDSEL pin capacitance			8	pF	4
L_{PIN}	Pin inductance			20	nH	

V961PBC

Notes:

1. Input leakage currents include high impedance output leakage for all bi-directional buffers with tri-state outputs.
2. Signals without pullup resistors have greater than 3mA low output current. Signals requiring pull resistors have greater than 6mA output current. The latter include **FRAME**, **TRDY**, **IRDY**, **STOP**, **SERR**, **PERR**.
3. Absolute maximum pin capacitance for a PCI unit is 10pF (except for CLK).
4. Lower capacitance on this input-only pin allows for non-resistive coupling to AD[xx].

3.2 Local Bus DC Specifications

Table 9: Local Bus Signals DC Operating Specifications

Symbol	Description	Conditions	Min	Max	Units
V _{IL}	Low level input voltage	V _{CC} = 4.75V		0.8	V
V _{IH}	High level input voltage	V _{CC} = 5.25V	2.0		V
I _{IL}	Low level input current	V _{IN} =GND, V _{CC} =5.25V	-10		μA
I _{IH}	High level input current	V _{IN} = V _{CC} = 5.25V		10	μA
V _{OL4}	Low level output voltage for 4 mA outputs and I/O pins	I _{OL} = -4 mA		0.4	V
V _{OH4}	High level output voltage for 4 mA outputs and I/O pins	I _{OH} = 4 mA	2.4		V
I _{OZL}	Low level float input leakage	V _{IN} = GND	-10		μA
I _{OZH}	High level float input leakage	V _{IN} = V _{CC}		10	μA
I _{CC} (max)	Maximum supply current	V _{CC} = 5.25V PCLK = LCLK = 33MHz		150	mA
I _{CC} (typ)	Typical supply current	V _{CC} = 5.0V PCLK = LCLK = 33MHz		120	mA
C _{IO}	Input and output capacitance			10	pF

4.0 AC Specifications

The AC specifications for the PCI bus signals match exactly those given in the PCI Specification, Rev. 2.1, Section 4.2.1.2. For more information on the PCI AC specifications, including the V/I curves for 5V signalling, see section 4.2.1.2 of Rev 2.1 PCI Specification.

4.1 PCI Bus Timings

Table 10: PCI Bus Signals AC Operating Specifications

Symbol	Parameter	Condition	Min	Max	Units	Notes
$I_{OH(AC)}$	Switching current high	$0V < V_{OUT} \leq 1.4V$	-44		mA	1
		$1.4V < V_{OUT} < 2.4V$	$-44 + (V_{OUT} - 1.4)/0.024$	Equation A	mA	1, 2, 3
	(Test point)	$V_{OUT} = 3.1V$		-142	mA	3
$I_{OL(AC)}$	Switching current low	$V_{OUT} \geq 2.2V$	95		mA	1
		$2.2V > V_{OUT} > 0.55V$	$V_{OUT}/0.023$	Equation B	mA	1, 3
	(Test point)	$V_{OUT} = 0.71V$		206	mA	3
I_{CL}	Low clamp current	$-5 < V_{IN} \leq -1$	$-25 + (V_{IN} + 1)/0.015$		mA	
t_R	Unloaded output rise time	0.4V to 2.4V	1	5	V/ns	4
t_F	Unloaded output fall time	2.4V to 0.4V	1	5	V/ns	4

Notes:

- Refer to the V/I curves in Section 4.2.1 of the PCI Specification. This specification does not apply to CLK and RST which are system outputs. "Switching Current High" specifications are not relevant to open drain outputs such as SERR and INTA-INTD.
- Note that this segment of the minimum current curve is drawn from the AC drive point directly to the DC drive point rather than toward the voltage rail (as it does in the pull-down curve). This difference is intended to allow for an optional N-channel pullup.
- Maximum current requirements are met as drivers pull beyond the first step voltage (AC drive point). Equations defining these maximums (A and B) are provided with the respective V/I curves given in the PCI Spec. The equation defined maxima is met by design.
- The minimum slew rate (slowest signal edge) is met by the PCI drivers. The maximum slew rate (fastest signal edge) is a guideline. Motherboard designers must bear in mind that rise and fall times faster than this maximum guideline could occur, and should ensure that signal integrity modeling accounts for this.

$$\text{Equation A: } I_{OH} = 11.9 \cdot (V_{OUT} - 5.25V) \cdot (V_{OUT} + 2.45V) \text{ for } V_{CC} > V_{OUT} > 3.1V$$

$$\text{Equation B: } I_{OL} = 78.5 \cdot V_{OUT} (4.4V - V_{OUT}) \text{ for } 0V < V_{OUT} < 0.71V$$

4.2 Local Bus Timings

Table 11: i960Jx Local Bus AC Test Conditions

Symbol	Parameter	Limits	Units
V_{CC}	Supply voltage	4.75 to 5.25	V
V_{IN}	Input low and high voltages	0.4 and 2.0	V
C_{OUT}	Capacitive load on output and I/O pins	50	pF

Table 12: Capacitive Derating for Output and I/O Pins

Output Drive Limit	Derating
4mA	0.058 ns/pF for loads > 50pF

Figure 3: Clock and Synchronous Signals

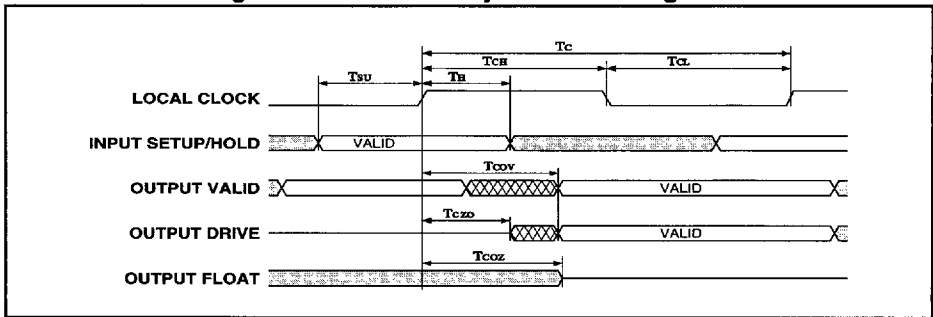

Figure 4: ALE Signal

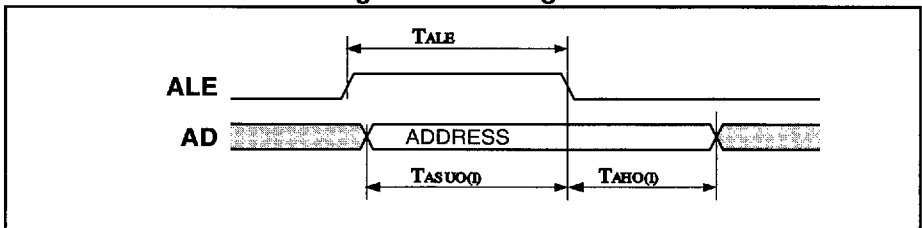

Table 13: Local Bus Timing Parameters for Vcc = 5 Volts +/- 5%

			33MHz		40MHz			
#	Symbol	Description	Notes	Min	Max	Min	Max	Units
1	T _C	LCLK period		30		25		ns
2	T _{CH}	LCLK high time	1	12		11		ns
3	T _{CL}	LCLK low time	1	12		11		ns
4	T _{SU}	Synchronous input setup	2	11		10		ns
4a	T _{SU}	Synchronous input setup (BLAST)		13		11		ns
5	T _H	Synchronous input hold			3		3	ns
6	T _{COV}	LCLK to output valid delay	3	3	14	3	13	ns
7a	T _{COV}	LCLK to output valid delay (address, data, byte enable, parity)		4	19	4	17	ns
8	T _{CZO}	LCLK to output driving delay		5	18	4	16	ns
9	T _{COZ}	LCLK to high impedance delay	4	5	18		16	ns
10	T _{RST}	Reset period when LRST used as input		16·T _C		16·T _C		ns

Notes:

1. Measured at 1.5V.
2. All local bus signals except those in 4a.
3. All local bus signals except those in 7a.
4. RDYRCV, BLAST, ADS are driven to high impedance at the falling edge of LCLK.

Table 14: ALE Timing Parameters for Vcc = 5 Volts +/- 5%

			33MHz		40MHz			
#	Symbol	Description	Min	Max	Min	Max	Units	
1	T _{ALE}	ALE Pulse Width	T _{CH} -4		T _{CH} -4		ns	
2	T _{ASUO}	Address setup to ALE falling (ALE as output)	T _{CH} -5		T _{CH} -4		ns	
3	T _{AHO}	Address hold from ALE falling (ALE as output)	T _{CL} -5		T _{CL} -4		ns	
4	T _{ASUI}	Address setup to ALE falling (ALE as input)	5		5		ns	
5	T _{AHI}	Address hold from ALE falling (ALE as input)	5		5		ns	

Table 15: PCI Bus Timing Parameters for Vcc = 5 Volts +/- 5%

#	Symbol	Description	Notes	Min	Max	Units
1	T_C	PCLK period		30		ns
2	T_{SU}	Synchronous input setup to PCLK	1	7		ns
2a	T_{SU}	Synchronous input setup to PCLK (\overline{GNT})		10		ns
3	T_H	Synchronous input hold from PCLK		0		ns
4	T_{COV}	PCLK to output valid delay	2	3	11	ns
4a	T_{COV}	PCLK to output valid delay (\overline{REQ})		4	12	ns
5	T_{CZO}	PCLK to output driving delay		4	11	ns
6	T_{COZ}	PCLK to high impedance delay		5	18	ns
7	T_{RST}	Reset period when PRST used as input		$16 \cdot T_C$		

Notes:

1. All PCI bus signals except those in 2a.
2. All PCI bus signals except those in 4a.

4.3 Serial EEPROM Port Timings

The clock for the serial EEPROM interface is derived by dividing the PCI bus clock. The waveforms generated are shown in Figure 5.

Figure 5: Serial EEPROM Waveforms and Timings

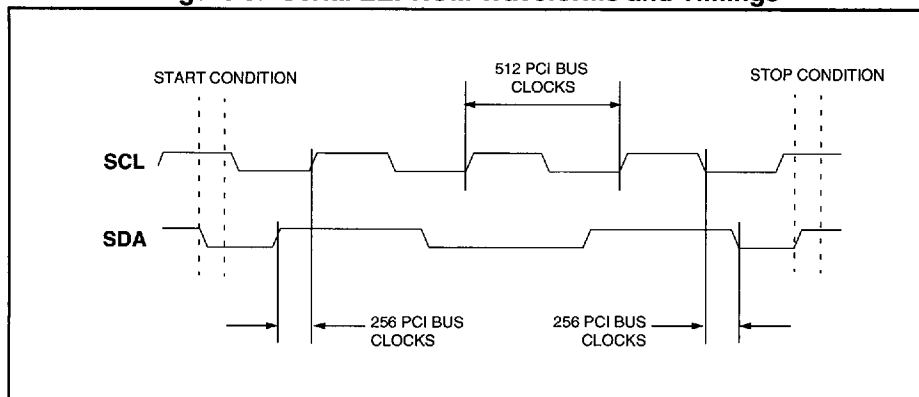

5.0 Revision History

Table 16: Revision History

Revision Number	Date	Comments and Changes
2.3	10/96	Data Book revision. 1. In Table 3, changed " <u>LPAR[3:0]</u> " to " <u>LPAR[3:0]</u> ".
2.2	06/96	1. In Table 3, changed "PERR I/OD" to "PERR I/O". 2. In Table 3, added " <u>V_{CC}</u> " and " <u>GND</u> " description. 3. In Table 13 and 14 , added min <u>T_{COV}</u> and min <u>T_{CZO}</u> timing.
2.1	03/96	1. Updated timings to final B1-step values. 2. Simplified data sheet format.
2.0	11/95	Removed operational description (found in User's Manual). Device related changes: 1. LA5, LA4, LA3, LA2 pins added to pinout for V960PBC and V961PBC. 2. Changed references to PCI 2.0 to PCI 2.1 spec level compliance. 3. Updated timings to final B0-step values. 4. Added new <u>T_{CZO}</u> timing. 5. Added test mode pin description.
1.3	4/95	1. In Table 1, changed Draining Strategy to "3 or more words" from "4 or more writes". 2. In Table 3, changed Base Address 3 to Unimplemented. 3. In Table 5, changed " <u>PAR</u> " to " <u>PAR</u> ". 4. In Table 6, changed " <u>SCL</u> " to " <u>SCL/PERR</u> ". 5. In Table 6, changed SDA to " <u>I/O₄</u> from " <u>O₄</u> ". 6. In Table 6, changed <u>ROMCSx</u> , <u>LREQ</u> , and <u>ADS</u> to " <u>I/O₄</u> " from " <u>O₄</u> " (device dependent). 7. In Table 6, changed <u>GREQ</u> , <u>LBREQ</u> , and <u>HOLD</u> to " <u>O₄</u> " from " <u>I/O₄</u> " (device dependent). 8. In Table 6, changed <u>BURST</u> and <u>BLAST</u> to " <u>I/O₄</u> " from " <u>O₄</u> " (device dependent). 9. In Table 6, changed <u>ERR</u> and <u>BTERM</u> to " <u>I/O₄</u> " from " <u>O₄</u> " (device dependent). 10. In Table 14, added timings for 16MHz and 40MHz (device dependent).
1.2	3/95	First released version of the data sheet. Some changes to AC and DC specifications and to waveforms. All future changes to the data sheet will be documented in detail in this section.
1.1	2/95	Clean pinouts. Some DC and AC specs. Sent only to a limited number of customers.
1.0	1/95	First pre-silicon revision of preliminary data sheet. DC and AC specs TBD. Sent only to a limited number of customers.

Package Specifications

Package outlines are listed in ascending pin count order. For information on device ordering codes, see *Ordering Information* in this data book. Package outline dimensions are shown in each diagram.

Package Selection Guide

DEVICE	PQFP	BGA
V960PBC V961PBC V962PBC V292PBC	160	
V96DPC		313
V96BMC V292BMC	132	
V96SSC	100	

100-pin EIAJ PQFP (Plastic Quad Flat Pack) Mechanical Details

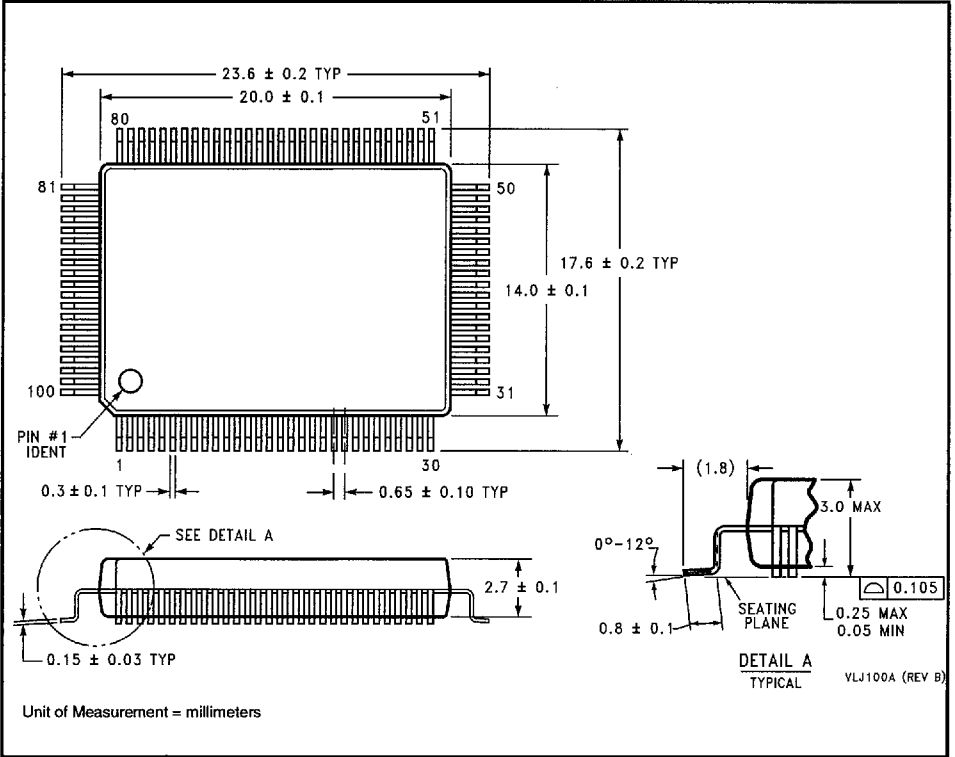

Products: V96SSC

132-pin PQFP (Plastic Quad Flat Pack) Mechanical Details

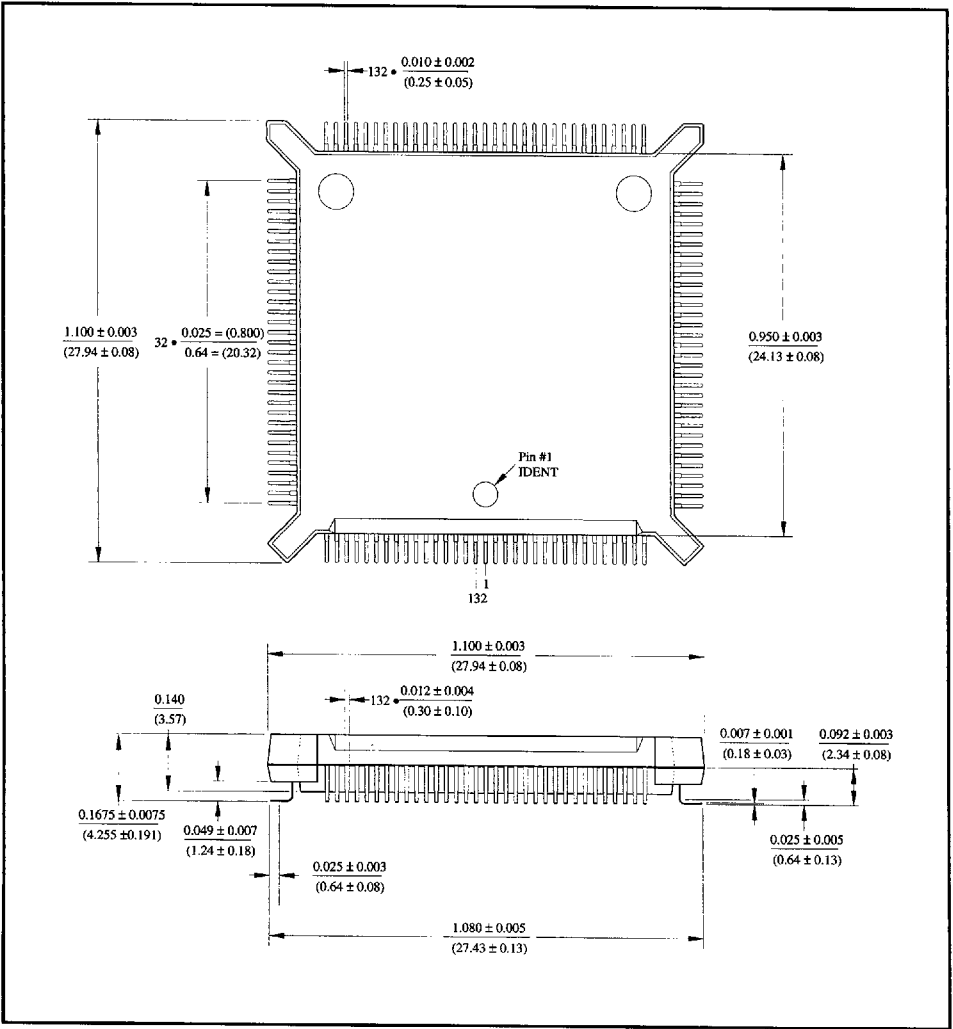

Products: V96BMC, V292BMC

Note: Controlling measurement is in inches. Millimeter measurement, shown in parentheses, are for reference only.

160-pin EIAJ PQFP (Plastic Quad Flat Pack) Mechanical Details

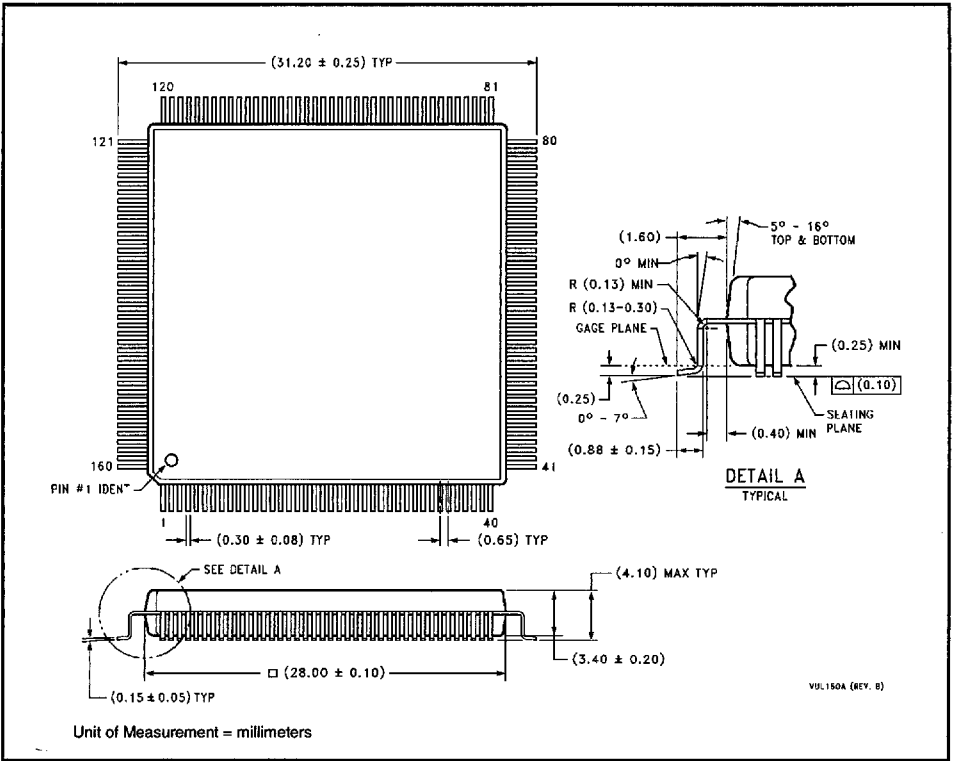

Products: V960PBC, V961PBC, V962PBC, V292PBC

313-pin BGA (Ball Grid Array) Mechanical Details

Dimensions are in millimeters.

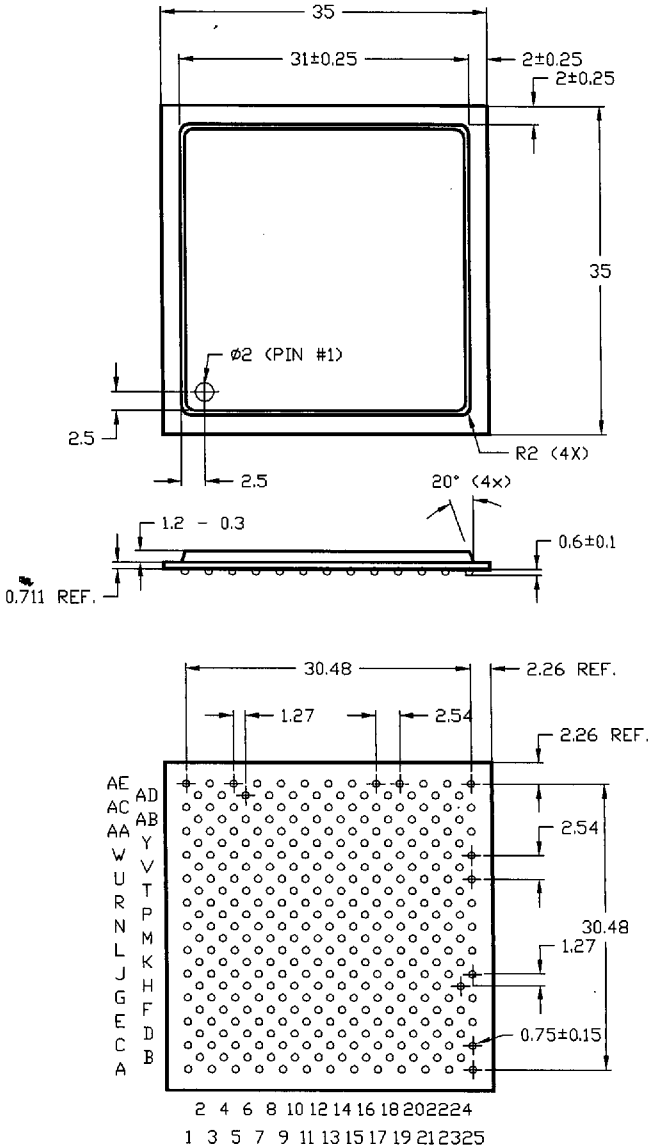

Products: V96DPC