

National Semiconductor is now part of  
Texas Instruments.

Search <http://www.ti.com/> for the latest technical  
information and details on our current products and services.

## 3-Terminal Negative Regulators

### General Description

The LM320L/LM79LXXAC dual marked series of 3-terminal negative voltage regulators features fixed output voltages of  $-5V$ ,  $-12V$ , and  $-15V$  with output current capabilities in excess of  $100mA$ . These devices were designed using the latest computer techniques for optimizing the packaged IC thermal/electrical performance. The LM79LXXAC series, even when combined with a minimum output compensation capacitor of  $0.1\mu F$ , exhibits an excellent transient response, a maximum line regulation of  $0.07\% V_O/V$ , and a maximum load regulation of  $0.01\% V_O/mA$ .

The LM320L/LM79LXXAC series also includes, as self-protection circuitry: safe operating area circuitry for output transistor power dissipation limiting, a temperature independent short circuit current limit for peak output current limiting, and a thermal shutdown circuit to prevent excessive junction temperature. Although designed primarily as fixed voltage regulators, these devices may be combined with simple external circuitry for boosted and/or adjustable voltages and currents. The LM79LXXAC series is available in the 3-lead TO-92

package, 8-lead SOIC package, and the 6-Bump micro SMD package. The LM320L series is available in the 3-lead TO-92 package.

For output voltage other than  $-5V$ ,  $-12V$  and  $-15V$ , the LM137L series provides an output voltage range from  $1.2V$  to  $47V$ .

### Features

- Preset output voltage error is less than  $\pm 5\%$  overload, line and temperature
- Specified at an output current of  $100mA$
- Easily compensated with a small  $0.1\mu F$  output capacitor
- Internal short-circuit, thermal and safe operating area protection
- Easily adjustable to higher output voltages
- Maximum line regulation less than  $0.07\% V_{OUT}/V$
- Maximum load regulation less than  $0.01\% V_{OUT}/mA$
- See AN-1112 for micro SMD considerations

### Typical Applications

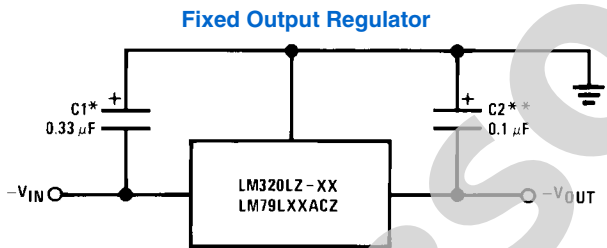

774801

\*Required if the regulator is located far from the power supply filter. A  $1\mu F$  aluminum electrolytic may be substituted.

\*\*Required for stability. A  $1\mu F$  aluminum electrolytic may be substituted.

### Adjustable Output Regulator

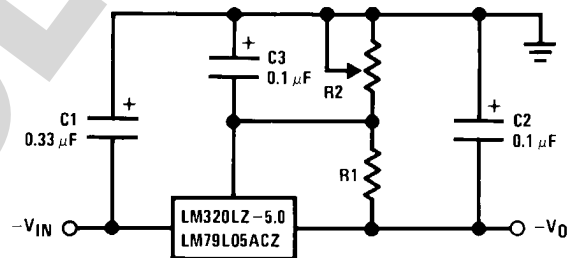

774803

$$-V_0 = -5V - (5V/R1 + I_O) \cdot R2,$$

$$5V/R1 > 3 I_O$$

### Connection Diagrams

#### 6-Bump micro SMD

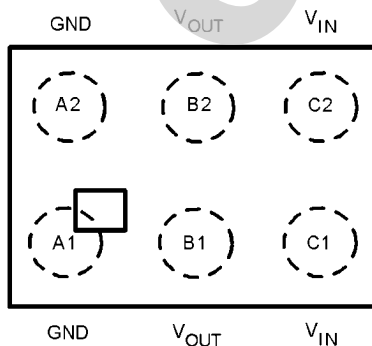

774820

Bump Side Down

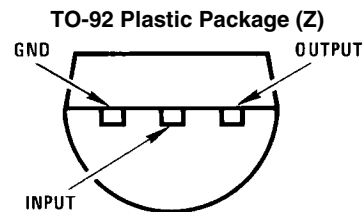

Bottom View

774802

## SO-8 Plastic (Narrow Body)

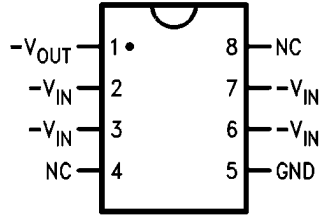

Top View

774804

## Ordering Information

Package	Part Number	Package Marking	Transport Media	NSC Drawing
8-Lead SOIC	LM79L05ACM	LM79L05ACM	95 Units/Rail	M08A
	LM79L05ACMX		2.5k Units Tape and Reel	
	LM79L12ACM	LM79L12ACM	95 Units/Rail	
	LM79L12ACMX		2.5k Units Tape and Reel	
	LM79L15ACM	LM79L15ACM	95 Units/Rail	
	LM79L15ACMX		2.5k Units Tape and Reel	
3-Pin TO-92	LM79L05ACZ	320L79L05	1800 Units Per Box	Z03A
	LM79L12ACZ	320L79L12	1800 Units Per Box	
	LM79L15ACZ	320L79L15	1800 Units Per Box	
6-Bump micro SMD	LM79L15ACTL	XTPB	250 Units Tape and Reel	TLA06AMA
	LM79L05ACTLX		3k Units Tape and Reel	

**Absolute Maximum Ratings** (Note 1)

If Military/Aerospace specified devices are required, please contact the National Semiconductor Sales Office/Distributors for availability and specifications.

Input Voltage  
 $V_O = -5V, -12V, -15V$  -35V

Internal Power Dissipation (Note 2)

Operating Temperature Range

Maximum Junction Temperature

Storage Temperature Range

Lead Temperature

(Soldering, 10 sec.)

Internally Limited

0°C to +70°C

+125°C

-55°C to +150°C

260°C

**Electrical Characteristics** (Note 3)

$T_A = 0^\circ\text{C}$  to  $+70^\circ\text{C}$  unless otherwise noted.

Output Voltage			-5V			-12V			-15V			Units
Input Voltage (unless otherwise noted)			-10V			-17V			-20V			
Symbol	Parameter	Conditions	Min	Typ	Max	Min	Typ	Max	Min	Typ	Max	
$V_O$	Output Voltage	$T_J = 25^\circ\text{C}, I_O = 100\text{mA}$	-5.2	-5	-4.8	-12.5	-12	-11.5	-15.6	-15	-14.4	V
		$1\text{mA} \leq I_O \leq 100\text{mA}$	-5.25		-4.75	-12.6		-11.4	-15.75		-14.25	
		$V_{\text{MIN}} \leq V_{\text{IN}} \leq V_{\text{MAX}}$			$(-20 \leq V_{\text{IN}} \leq -7.5)$			$(-27 \leq V_{\text{IN}} \leq -14.8)$			$(-30 \leq V_{\text{IN}} \leq -18)$	
		$1\text{mA} \leq I_O \leq 40\text{mA}$	-5.25		-4.75	-12.6		-11.4	-15.75		-14.25	
		$V_{\text{MIN}} \leq V_{\text{IN}} \leq V_{\text{MAX}}$			$(-20 \leq V_{\text{IN}} \leq -7)$			$(-27 \leq V_{\text{IN}} \leq -14.5)$			$(-30 \leq V_{\text{IN}} \leq -17.5)$	
$\Delta V_O$	Line Regulation	$T_J = 25^\circ\text{C}, I_O = 100\text{mA}$			60			45			45	mV
		$V_{\text{MIN}} \leq V_{\text{IN}} \leq V_{\text{MAX}}$			$(-20 \leq V_{\text{IN}} \leq -7.3)$			$(-27 \leq V_{\text{IN}} \leq -14.6)$			$(-30 \leq V_{\text{IN}} \leq -17.7)$	V
		$T_J = 25^\circ\text{C}, I_O = 40\text{mA}$			60			45			45	mV
		$V_{\text{MIN}} \leq V_{\text{IN}} \leq V_{\text{MAX}}$			$(-20 \leq V_{\text{IN}} \leq -7)$			$(-27 \leq V_{\text{IN}} \leq -14.5)$			$(-30 \leq V_{\text{IN}} \leq -17.5)$	V
$\Delta V_O$	Load Regulation	$T_J = 25^\circ\text{C}$			50			100			125	mV
		$1\text{mA} \leq I_O \leq 100\text{mA}$										
$\Delta V_O$	Long Term Stability	$I_O = 100\text{mA}$		20			48		60			mV/ khrs
$I_Q$	Quiescent Current	$I_O = 100\text{mA}$		2	6		2	6		2	6	mA
$\Delta I_Q$	Quiescent Current Change	$1\text{mA} \leq I_O \leq 100\text{mA}$			0.3			0.3			0.3	mA
		$1\text{mA} \leq I_O \leq 40\text{mA}$			0.1			0.1			0.1	
		$I_O = 100\text{mA}$			0.25			0.25			0.25	mA
		$V_{\text{MIN}} \leq V_{\text{IN}} \leq V_{\text{MAX}}$			$(-20 \leq V_{\text{IN}} \leq -7.5)$			$(-27 \leq V_{\text{IN}} \leq -14.8)$			$(-30 \leq V_{\text{IN}} \leq -18)$	V
$V_n$	Output Noise Voltage	$T_J = 25^\circ\text{C}, I_O = 100\text{mA}$		40			96		120			$\mu\text{V}$
		$f = 10\text{Hz} - 10\text{kHz}$										
$\frac{\Delta V_{\text{IN}}}{\Delta V_O}$	Ripple Rejection	$T_J = 25^\circ\text{C}, I_O = 100\text{mA}$ $f = 120\text{Hz}$	50			52			50			dB
	Input Voltage Required to Maintain Line Regulation	$T_J = 25^\circ\text{C}, I_O = 100\text{mA}$			-7.3			-14.6			-17.7	V
		$I_O = 40\text{mA}$			-7.0			-14.5			-17.5	V

**Note 1:** Absolute Maximum Ratings indicate limits beyond which damage to the device may occur. Operating Ratings indicate conditions for which the device is functional, but do not guarantee specific performance limits.

**Note 2:** Thermal resistance of Z package is  $60^\circ\text{C}/\text{W}$   $\theta_{\text{JC}}$ ,  $232^\circ\text{C}/\text{W}$   $\theta_{\text{JA}}$  at still air, and  $88^\circ\text{C}/\text{W}$  at 400 ft/min of air. The M package  $\theta_{\text{JA}}$  is  $180^\circ\text{C}/\text{W}$  in still air. The maximum junction temperature shall not exceed  $125^\circ\text{C}$  on electrical parameters.

**Note 3:** To ensure constant junction temperature, low duty cycle pulse testing is used.

# Typical Performance Characteristics

Maximum Average Power Dissipation (TO-92)

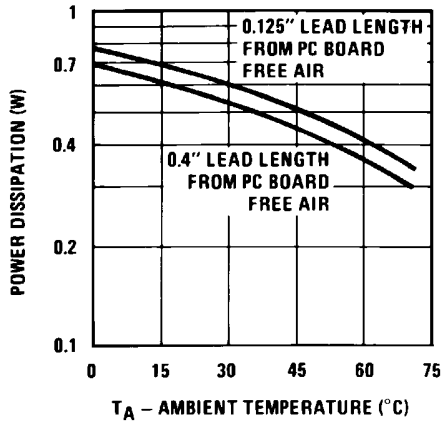

774811

Peak Output Current

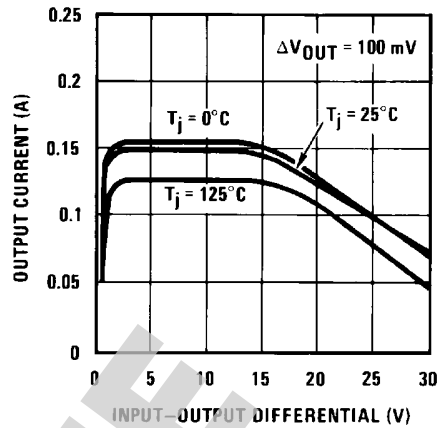

774812

Short Circuit Output Current

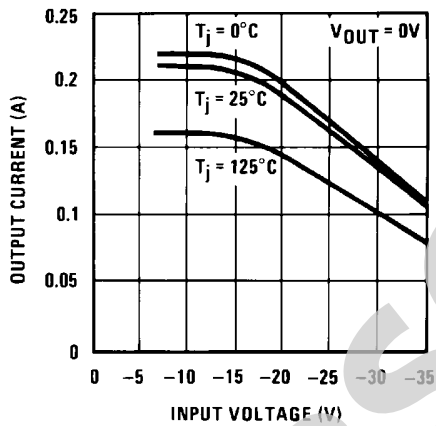

774813

Dropout Voltage

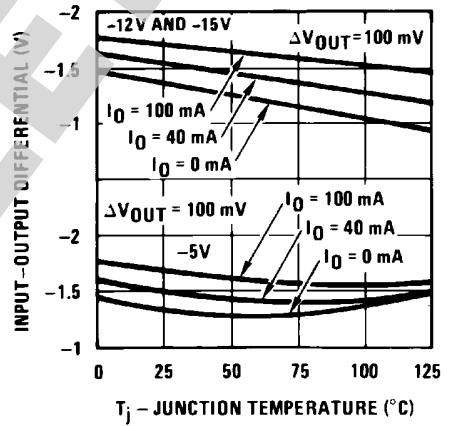

774814

Ripple Rejection

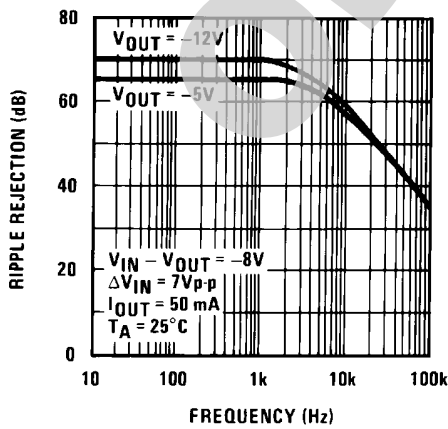

774815

Output Voltage vs. Temperature (Normalized to 1V @ 25°C)

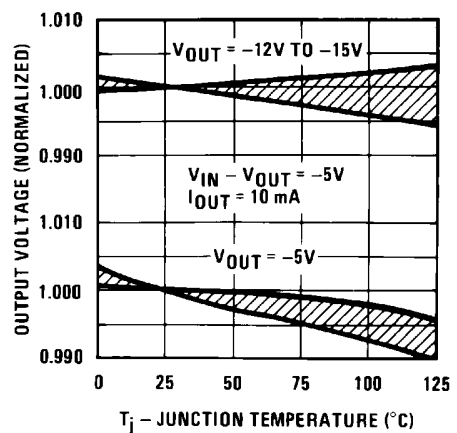

774816

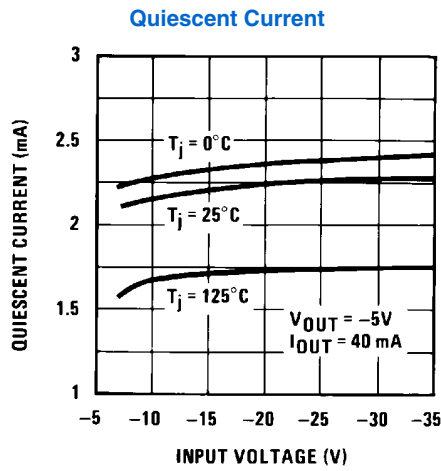

774817

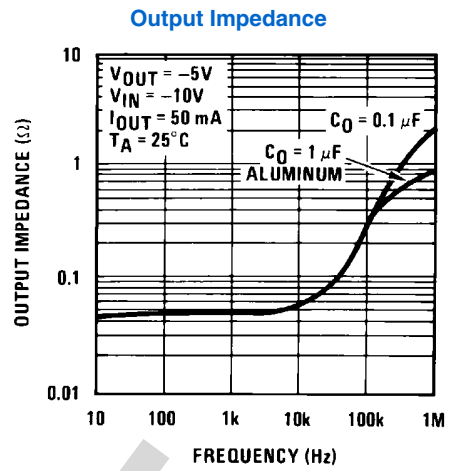

774818

## Typical Applications

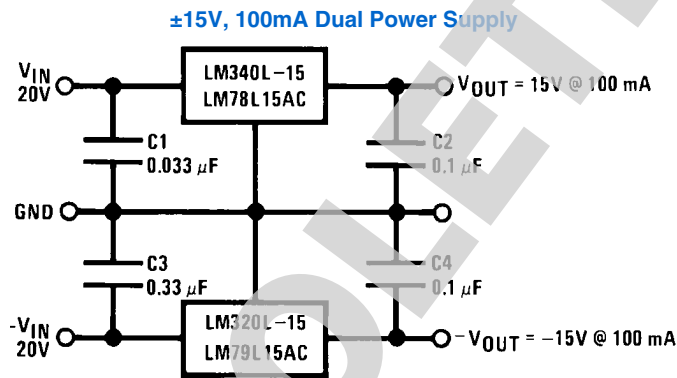

774806

# Schematic Diagrams

-5V

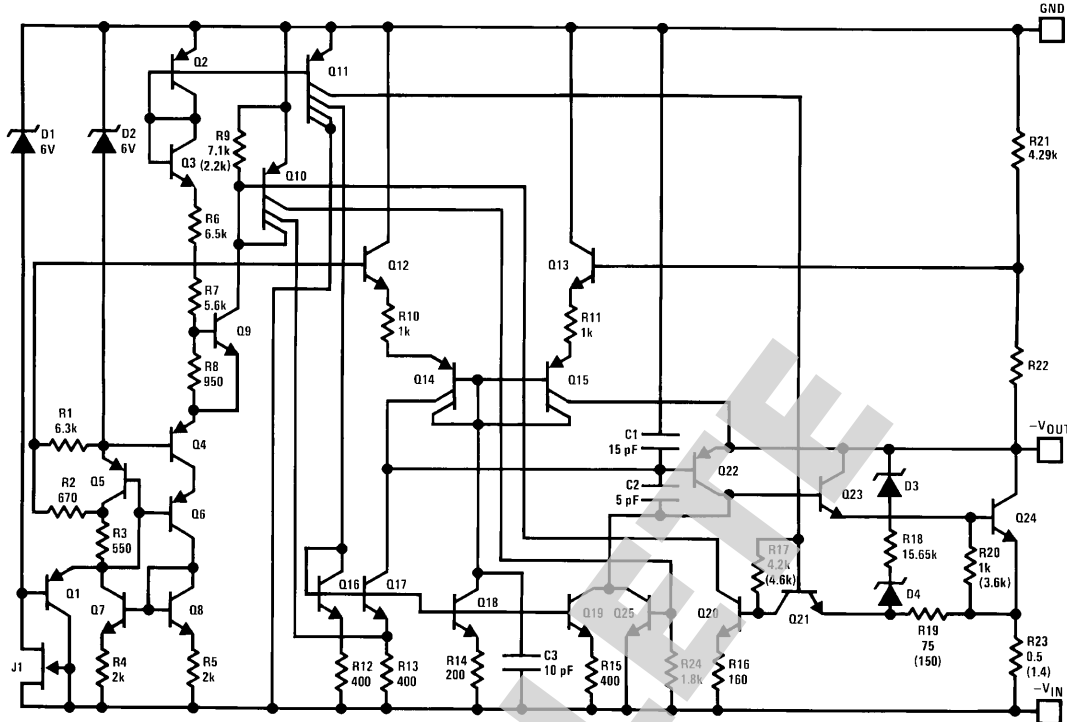

774809

-12V and -15V

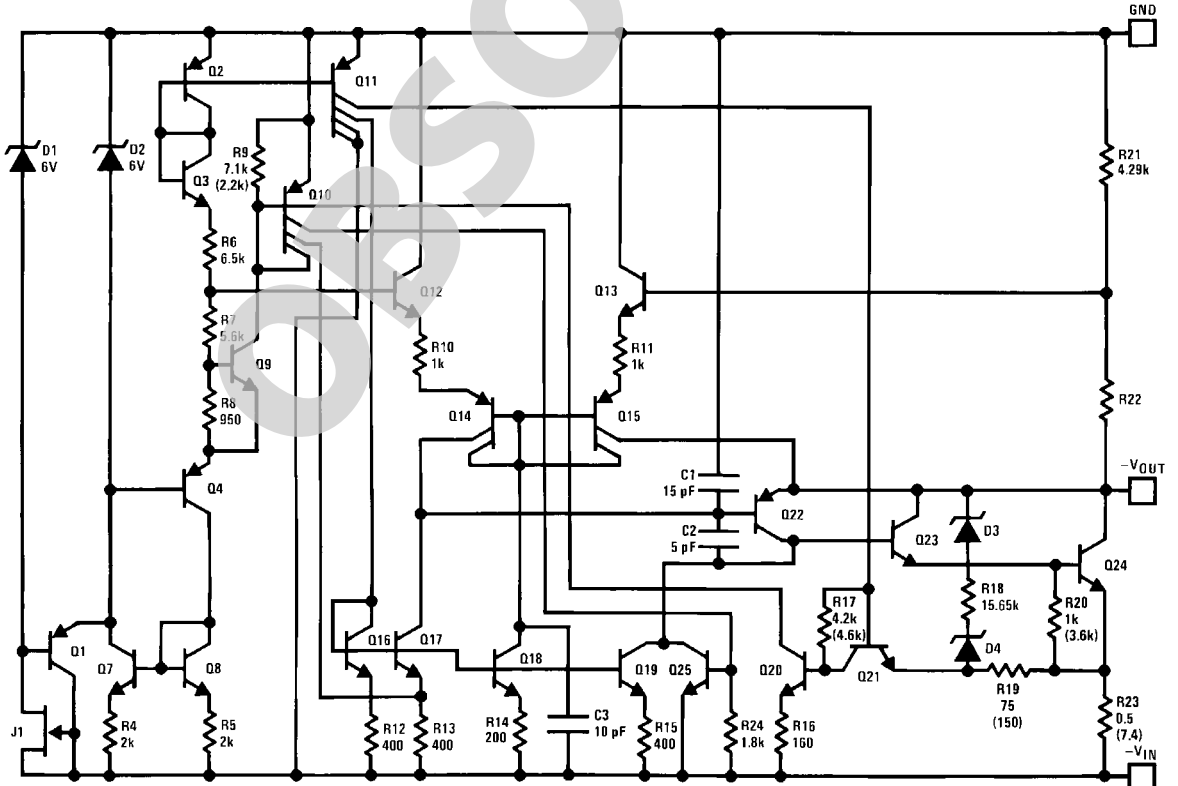

774810

**Physical Dimensions** inches (millimeters) unless otherwise noted

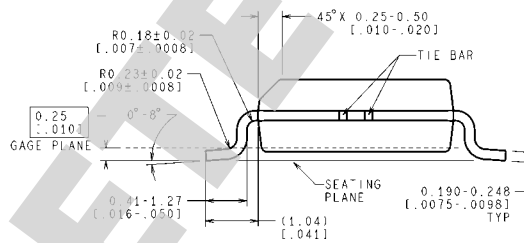
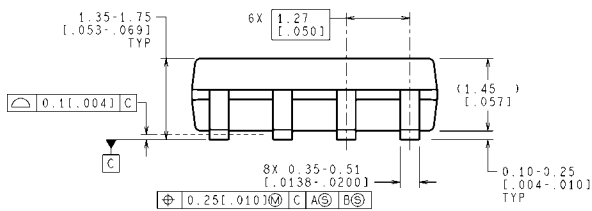
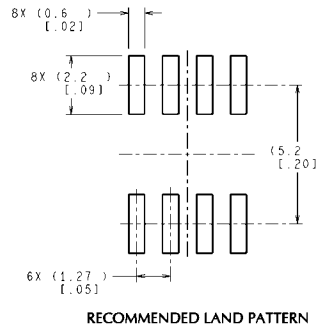
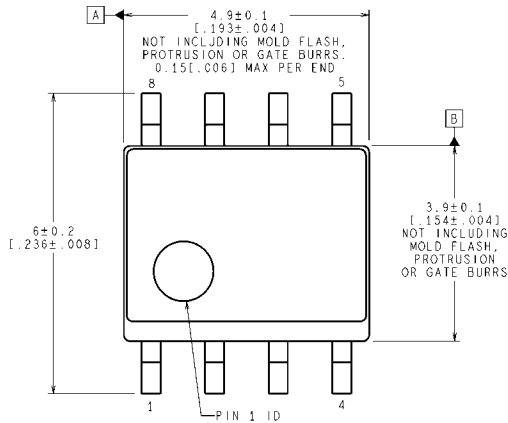

CONTROLLING DIMENSION IS MILLIMETER  
VALUES IN [ ] ARE INCHES  
DIMENSIONS IN ( ) FOR REFERENCE ONLY

M08A (Rev M)

**SOIC Package (M)**  
**NS Package Number M08A**

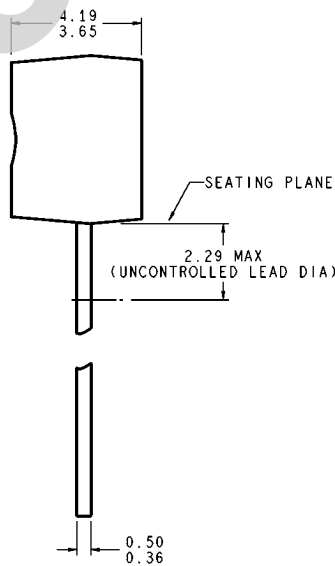
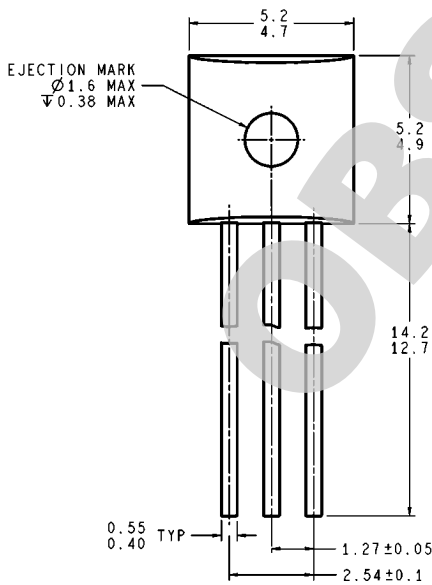

DIMENSIONS ARE IN MILLIMETERS

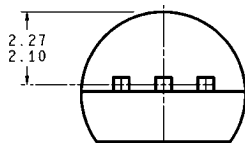

Z03A (Rev G)

**Molded Offset TO-92 (Z)**  
**NS Package Number Z03A**



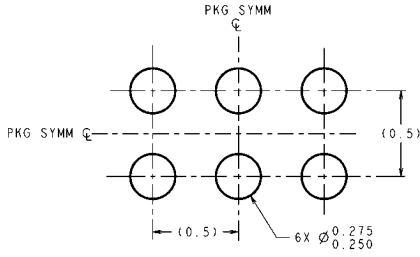

DIMENSIONS ARE IN MILLIMETERS  
DIMENSIONS IN ( ) FOR REFERENCE ONLY

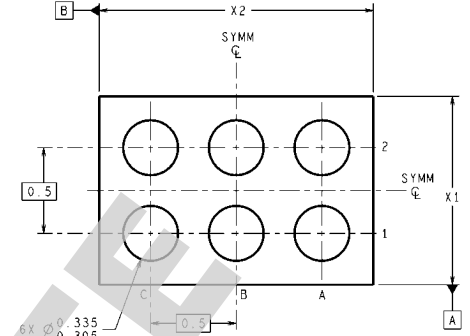
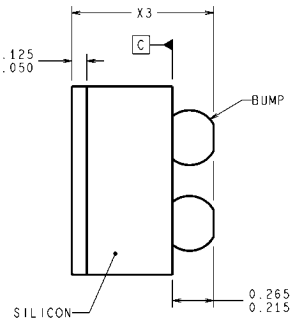
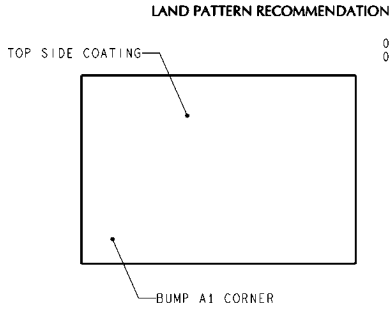

⊕ 0.005 | C | A | B

TLA06XXX (Rev C)

NOTES: UNLESS OTHERWISE SPECIFIED

1. EPOXY COATING.
2. 63Sn/67Pb EUTECTIC BUMP.
3. RECOMMEND NON-SOLDER MASK DEFINED LANDING PAD.
4. PIN A1 ESTABLISHED BY LOWER LEFT CORNER WITH RESPECT TO TEXT ORIENTATION.
5. XXX IN DRAWING NUMBER REPRESENTS PACKAGE SIZE VARIATION WHERE X1 IS PACKAGE WIDTH, X2 IS PACKAGE LENGTH AND X3 IS PACKAGE HEIGHT.
6. REFERENCE JEDEC REGISTRATION MO-211, VARIATION BC.

**6-Bump micro SMD**  
**NS Package Number TLA06AMA**  
**X<sub>1</sub> = 1006μm X<sub>2</sub> = 1793μm X<sub>3</sub> = 600μm**

OBSOLETE

# Notes

LM320L/LM79LXXAC

**OBSOLETE**

## Notes

For more National Semiconductor product information and proven design tools, visit the following Web sites at:  
[www.national.com](http://www.national.com)

Products		Design Support	
Amplifiers	<a href="http://www.national.com/amplifiers">www.national.com/amplifiers</a>	WEBENCH® Tools	<a href="http://www.national.com/webench">www.national.com/webench</a>
Audio	<a href="http://www.national.com/audio">www.national.com/audio</a>	App Notes	<a href="http://www.national.com/appnotes">www.national.com/appnotes</a>
Clock and Timing	<a href="http://www.national.com/timing">www.national.com/timing</a>	Reference Designs	<a href="http://www.national.com/refdesigns">www.national.com/refdesigns</a>
Data Converters	<a href="http://www.national.com/adc">www.national.com/adc</a>	Samples	<a href="http://www.national.com/samples">www.national.com/samples</a>
Interface	<a href="http://www.national.com/interface">www.national.com/interface</a>	Eval Boards	<a href="http://www.national.com/evalboards">www.national.com/evalboards</a>
LVDS	<a href="http://www.national.com/lvds">www.national.com/lvds</a>	Packaging	<a href="http://www.national.com/packaging">www.national.com/packaging</a>
Power Management	<a href="http://www.national.com/power">www.national.com/power</a>	Green Compliance	<a href="http://www.national.com/quality/green">www.national.com/quality/green</a>
Switching Regulators	<a href="http://www.national.com/switchers">www.national.com/switchers</a>	Distributors	<a href="http://www.national.com/contacts">www.national.com/contacts</a>
LDOs	<a href="http://www.national.com/ldo">www.national.com/ldo</a>	Quality and Reliability	<a href="http://www.national.com/quality">www.national.com/quality</a>
LED Lighting	<a href="http://www.national.com/led">www.national.com/led</a>	Feedback/Support	<a href="http://www.national.com/feedback">www.national.com/feedback</a>
Voltage References	<a href="http://www.national.com/vref">www.national.com/vref</a>	Design Made Easy	<a href="http://www.national.com/easy">www.national.com/easy</a>
PowerWise® Solutions	<a href="http://www.national.com/powerwise">www.national.com/powerwise</a>	Applications & Markets	<a href="http://www.national.com/solutions">www.national.com/solutions</a>
Serial Digital Interface (SDI)	<a href="http://www.national.com/sdi">www.national.com/sdi</a>	Mil/Aero	<a href="http://www.national.com/milaero">www.national.com/milaero</a>
Temperature Sensors	<a href="http://www.national.com/tempensors">www.national.com/tempensors</a>	SolarMagic™	<a href="http://www.national.com/solarmagic">www.national.com/solarmagic</a>
PLL/VCO	<a href="http://www.national.com/wireless">www.national.com/wireless</a>	PowerWise® Design University	<a href="http://www.national.com/training">www.national.com/training</a>

THE CONTENTS OF THIS DOCUMENT ARE PROVIDED IN CONNECTION WITH NATIONAL SEMICONDUCTOR CORPORATION ("NATIONAL") PRODUCTS. NATIONAL MAKES NO REPRESENTATIONS OR WARRANTIES WITH RESPECT TO THE ACCURACY OR COMPLETENESS OF THE CONTENTS OF THIS PUBLICATION AND RESERVES THE RIGHT TO MAKE CHANGES TO SPECIFICATIONS AND PRODUCT DESCRIPTIONS AT ANY TIME WITHOUT NOTICE. NO LICENSE, WHETHER EXPRESS, IMPLIED, ARISING BY ESTOPPEL OR OTHERWISE, TO ANY INTELLECTUAL PROPERTY RIGHTS IS GRANTED BY THIS DOCUMENT.

TESTING AND OTHER QUALITY CONTROLS ARE USED TO THE EXTENT NATIONAL DEEMS NECESSARY TO SUPPORT NATIONAL'S PRODUCT WARRANTY. EXCEPT WHERE MANDATED BY GOVERNMENT REQUIREMENTS, TESTING OF ALL PARAMETERS OF EACH PRODUCT IS NOT NECESSARILY PERFORMED. NATIONAL ASSUMES NO LIABILITY FOR APPLICATIONS ASSISTANCE OR BUYER PRODUCT DESIGN. BUYERS ARE RESPONSIBLE FOR THEIR PRODUCTS AND APPLICATIONS USING NATIONAL COMPONENTS. PRIOR TO USING OR DISTRIBUTING ANY PRODUCTS THAT INCLUDE NATIONAL COMPONENTS, BUYERS SHOULD PROVIDE ADEQUATE DESIGN, TESTING AND OPERATING SAFEGUARDS.

EXCEPT AS PROVIDED IN NATIONAL'S TERMS AND CONDITIONS OF SALE FOR SUCH PRODUCTS, NATIONAL ASSUMES NO LIABILITY WHATSOEVER, AND NATIONAL DISCLAIMS ANY EXPRESS OR IMPLIED WARRANTY RELATING TO THE SALE AND/OR USE OF NATIONAL PRODUCTS INCLUDING LIABILITY OR WARRANTIES RELATING TO FITNESS FOR A PARTICULAR PURPOSE, MERCHANTABILITY, OR INFRINGEMENT OF ANY PATENT, COPYRIGHT OR OTHER INTELLECTUAL PROPERTY RIGHT.

#### LIFE SUPPORT POLICY

**NATIONAL'S PRODUCTS ARE NOT AUTHORIZED FOR USE AS CRITICAL COMPONENTS IN LIFE SUPPORT DEVICES OR SYSTEMS WITHOUT THE EXPRESS PRIOR WRITTEN APPROVAL OF THE CHIEF EXECUTIVE OFFICER AND GENERAL COUNSEL OF NATIONAL SEMICONDUCTOR CORPORATION.** As used herein:

Life support devices or systems are devices which (a) are intended for surgical implant into the body, or (b) support or sustain life and whose failure to perform when properly used in accordance with instructions for use provided in the labeling can be reasonably expected to result in a significant injury to the user. A critical component is any component in a life support device or system whose failure to perform can be reasonably expected to cause the failure of the life support device or system or to affect its safety or effectiveness.

National Semiconductor and the National Semiconductor logo are registered trademarks of National Semiconductor Corporation. All other brand or product names may be trademarks or registered trademarks of their respective holders.

Copyright© 2011 National Semiconductor Corporation

For the most current product information visit us at [www.national.com](http://www.national.com)



[www.national.com](http://www.national.com)

**National Semiconductor  
Americas Technical  
Support Center**  
Email: [support@nsc.com](mailto:support@nsc.com)  
Tel: 1-800-272-9959

**National Semiconductor Europe  
Technical Support Center**  
Email: [europe.support@nsc.com](mailto:europe.support@nsc.com)

**National Semiconductor Asia  
Pacific Technical Support Center**  
Email: [ap.support@nsc.com](mailto:ap.support@nsc.com)

**National Semiconductor Japan  
Technical Support Center**  
Email: [jpn.feedback@nsc.com](mailto:jpn.feedback@nsc.com)