

Host



PCMCIA Power Switching Solutions

V_{CC} : 3.3V or 5V
 V_{PP} : 0V, V_{CC} , 12V, High-Z

Cards

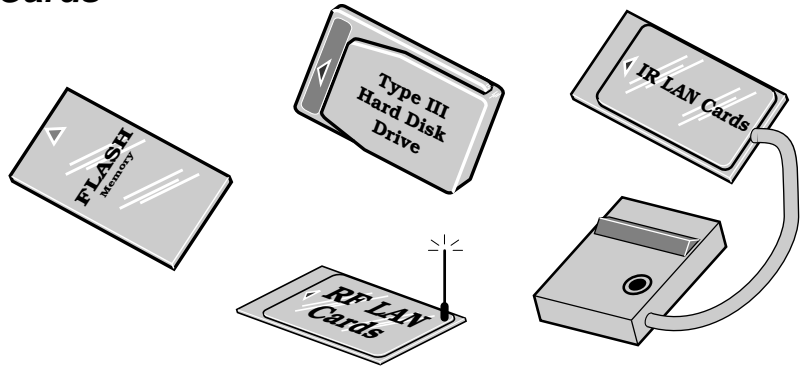

On-Card DC/DC Conversion Solutions (See pages 3 and 4)

PC Card Host Power Interface

Linear Technology PCMCIA Product Family

DEVICE	DESCRIPTION	PACKAGE
LT [®] 1312	Single PCMCIA VPP Driver/Regulator	8-Pin SOIC
LT1313	Dual PCMCIA VPP Driver/Regulator	16-Pin SOIC*
LTC [®] 1314	Single PCMCIA Switch Matrix	14-Pin SOIC
LTC1315	Dual PCMCIA Switch Matrix	24-Pin SSOP
LTC1470	Protected V_{CC} 5V/3.3V Switch Matrix	8-Pin SOIC
LTC1471	Dual Protected V_{CC} 5V/3.3V Switch Matrix	16-Pin SOIC*
LTC1472	Protected V_{CC} and VPP Switch Matrix	16-Pin SOIC*

*Narrow Body

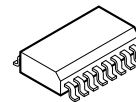

16-Lead SOIC
(Narrow Body)

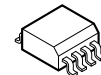

8-Lead SOIC

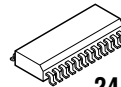

24-Lead SSOP

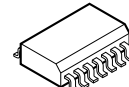

14-Lead SOIC

(Packages Enlarged for Clarity)

LTC1472 Protected PCMCIA V_{CC} and VPP Switching Matrix

- Both V_{CC} and VPP Switching in a Single Package
- Built-In SafeSlot™ Current Limit and Thermal Shutdown
- 16-Pin (Narrow) SOIC Package
- Inrush Current Limited (Drives 150 μ F Loads)
- Continuous 12V Power Not Required
- Extremely Low $R_{DS(ON)}$ NMOS Switches
- Guaranteed 1A V_{CC} Current and 120mA VPP Current
- 1 μ A Quiescent Current in Standby
- No External Components Required
- Compatible with Industry Standard Controllers
- Break-Before-Make Switching
- Controlled Rise and Fall Times
- Compatible with Cirrus Logic CL-PD6720, Intel 365-type and Other PCMCIA Host Adaptor Chips

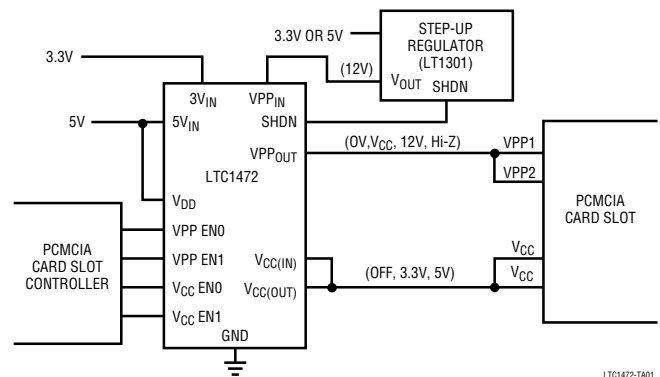
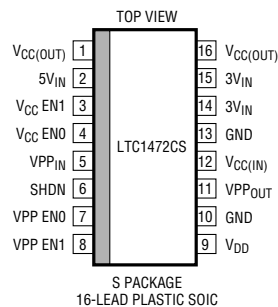

V_{CC} Switch Truth Table

V_{CC} EN0	V_{CC} EN1	$V_{CC}(OUT)$
0	0	Off
1	0	5V
0	1	3.3V
1	1	Off

VPP Switch Truth Table

VPP EN0	VPP EN1	VPP OUT
0	0	0V
0	1	$V_{CC}(IN)$
1	0	VPPIN
1	1	Hi-Z

LTC1470/LTC1471 Single/Dual PCMCIA Protected 5V/3.3V V_{CC} Switch

- 3.3V/5V Switching in 8-Pin SOIC Package
- Built-In SafeSlot Current Limit and Thermal Shutdown
- Extremely Low R_{DS(ON)} MOSFET Switches
- 1A Output Current Capability
- 1 μ A Quiescent Current in Standby
- Built-In Charge Pump (No 12V Required)
- Compatible with Industry Standard Controllers
- Break-Before-Make Switching
- Controlled Rise and Fall Times
- Logic Compatible with Standard PCMCIA Controllers
- LTC1470 (Single) and LTC1471 (Dual)

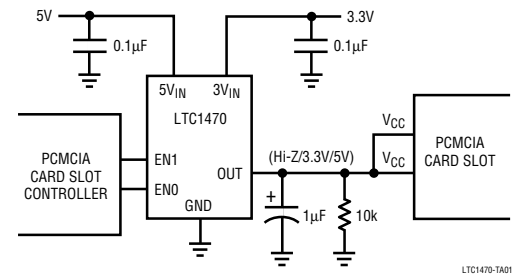
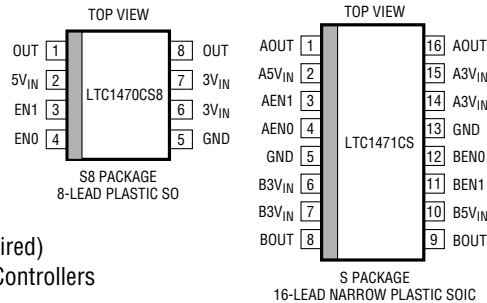

LTC1314/LTC1315 Single/Dual PCMCIA Switching Matrix with Built-In N-Channel MOSFET V_{CC} Switch Drivers

- Output Current Capability: 120mA
- 12V Regulator Can Be Shut Down
- Built-In N-Channel V_{CC} Switch Drivers
- Digital Selection of 0V, V_{CC(IN)}, VPP_{IN} or Hi-Z
- 3.3V or 5V V_{CC} Supply
- Break-Before-Make Switching
- 0.1 μ A Quiescent Current in Hi-Z or 0V Mode
- No VPP_{OUT} Overshoot
- Logic Compatible with Standard PCMCIA Controllers
- LTC1314 (Single) and LTC1315 (Dual)

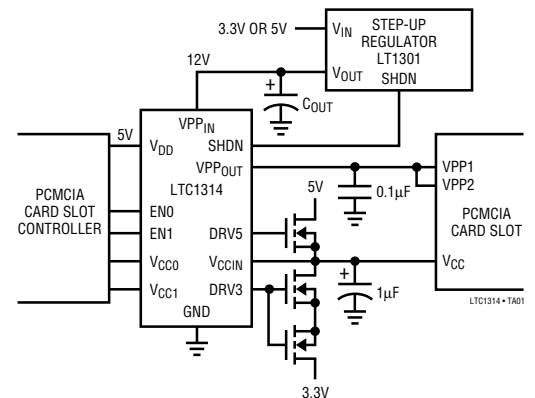
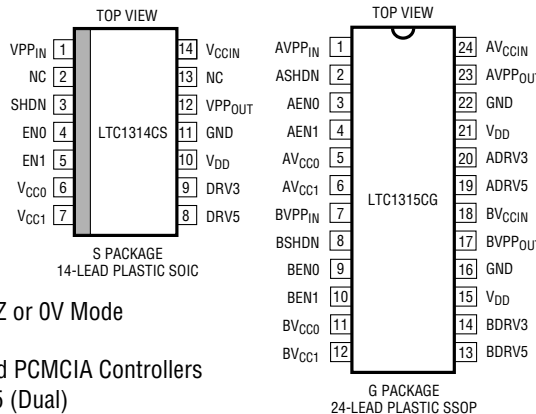

LT1312/LT1313 Single/Dual PCMCIA V_{CC} Driver/Regulator

- Digital Selection of 0V, V_{CC}, 12V or Hi-Z
- Output Current Capability: 120mA
- Internal Current Limiting and Thermal Shutdown
- Automatic Switching from 3.3V to 5V
- Powered from Unregulated 13V to 20V Supply
- Logic Compatible with Standard PCMCIA Controllers
- Output Capacitors: 1 μ F
- Quiescent Current in Hi-Z or 0V Mode: 60 μ A
- Independent VPP Valid Status Feedback Signals
- No VPP Overshoot

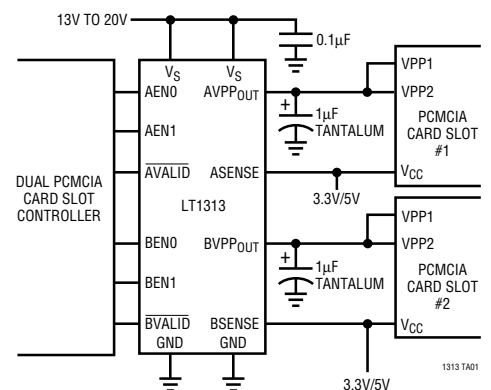
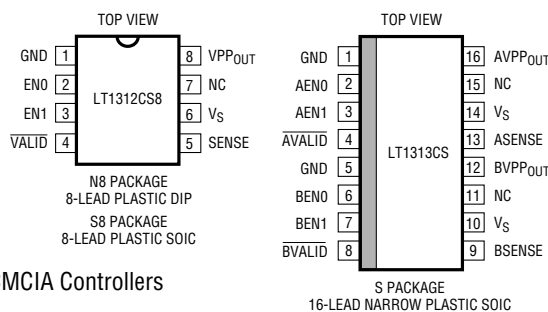

PCMCIA Type I and II Card Solutions (12V VPP Output)

V _{IN} (V)	V _{OUT} (V)	I _{OUT} (mA)	DEVICE	I _Q (μA) SHUTDOWN	FIG	COMMENTS
3.3 or 5	12	60	LT1106	10	1	1.1mm Max Component Height, Includes VPP Switching, Automatic 3.3V/5V V _{CC} Detect and VPP Bypass if 12V Present on VPP1 or VPP2

TSSOP PACKAGE!!

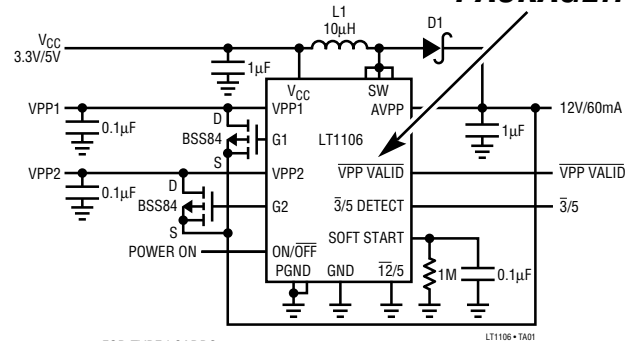

FOR TYPE I CARDS: —
 L1 = COILTRONICS CTX02-11238, DALE ILS-3825-0 (1.19mm MAX HEIGHT)
 D1 = 4 BAT54Cs IN PARALLEL (PHILIPS), 1.1mm MAX HEIGHT
 FOR TYPE II CARDS: —
 L1 = MURATA ERIE LQH3C100K04M00 (2.2mm MAX HEIGHT)
 D1 = PHILIPS PRL5818 (2.1mm MAX HEIGHT) OR MOTOROLA MBR0520LT

Figure 1. 12V, 60mA Flash Memory Programming Supply; 1.1mm Maximum Component Height

Flash Memory VPP (12V) Generation

V _{IN} (V)	V _{OUT} (V)	I _{OUT} (mA)	DEVICE	I _Q (μA)	L (μH)	C (μF)	FIG	COMMENTS
5	12	60	LT1109-12	320	33	22	2	Small, SMT
		120	LT1109A-12	320	27	47	2	Small, SMT
		200	LT1301*	120	27	47	3	15μA Shutdown Current
2 Cells	12	40	LT1109A-12	320	10	22	2	All Surface Mount
		50	LT1301*	120	10	47	3	15μA Shutdown Current

Step-Up From Two Cells or Three Cells

INPUT	V _{OUT} (V)	I _{OUT} (mA)	DEVICE	I _Q (μA)	L (μH)	C (μF)	R (Ω)	FIG	COMMENTS	
2 Cells (2V to 3V)	3.3	400	LT1300	120	10	100	—	3	Selectable 3.3V/5V Out	
		5	150	LT1107-5	300	33	33	47	4	Surface Mount
			110	LT1108-5	110	100	100	47	4	Lowest I _Q
	12	250	LT1300*	120	10	100	—	3	Selectable 3.3V/5V Out	
		120	LT1301	120	10	100	—	3	Selectable 5V/12V Out	
		600	LT1302	200	10	100	—	5	Highest Power Output	
3 Cells (2.7V to 4.5V)	5	250	LT1107-5	300	47	33	47	4	Surface Mount	
			110	LT1108-5	110	150	100	47	4	Lowest I _Q
		500	LT1300*	120	10	100	—	3	Selectable 3.3V/5V Out	
	120	LT1301	120	10	100	—	3	Selectable 5V/12V Out		
	1000	LT1302	200	10	100	—	5	Highest Power Output		
	12	60	LT1107-12	300	47	33	47	4	Surface Mount	
110			LT1108-12	110	150	100	47	4	Lowest I _Q	
75		LT1301	120	10	100	—	3	Selectable 5V/12V		

*LT1303 is functionally similar to LT1300/01, but has low-battery detection circuitry.

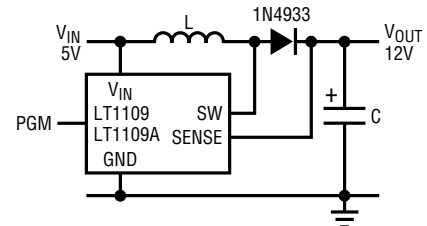

Figure 2. Flash Memory VPP Generator

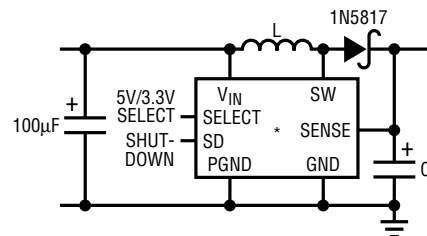

Figure 3. Basic Step-Up Converter

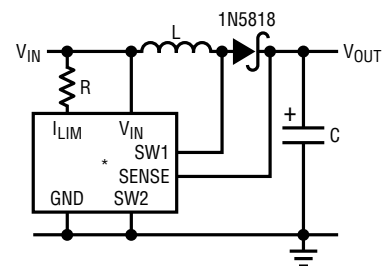
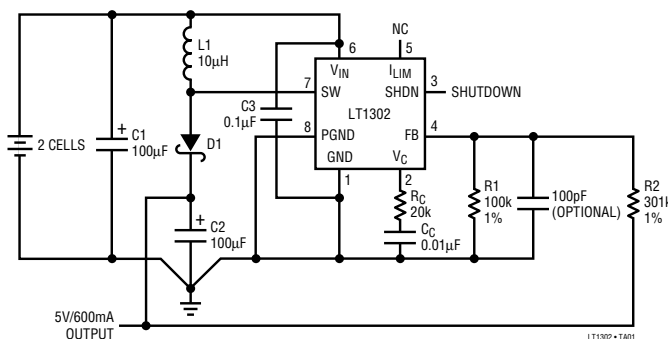

Figure 4. Basic Step-Up Converter

*SEE TABLE FOR RECOMMENDED PART, INDUCTOR, CAPACITOR AND RESISTOR VALUES



C1 = C2 = SANYO OS-CON
 L1 = COILTRONICS CTX10-3
 COILCRAFT D03316-103
 D1 = MOTOROLA MBR5130LT3

Figure 5. LT1302 High Current Step-Up from 2 Cells

Inductor and Capacitor Part Numbers/Manufacturers

INDUCTOR VALUE (μH)	COILTRONICS [†]	COILCRAFT [†]	SUMIDA [†]
10	CTX02-11238	–	–
15	–	DT3316-153	CD54-150LC
18	CTX20-1	–	CD54-180LC
20	CTX20-1	–	–
22	CTX20-1	DT3316-223	CD54-220LC
27	–	–	CD54-270LC
33	–	DT3316-473	CD54-330LC
47	CTX50-1	DT3316-683	CD74-470LC
68	–	DT3316-104	CD74-680LC
82	CTX82-1	DT3316-154	CD74-820LC
100	CTX100-1	–	CD105-101MC
120	CTX100-1	–	CD105-121MC
180	CTX250-4	–	CDR125-181MC
220	CTX250-4	–	CDR125-221MC
470	–	–	CDR125-471MC

[†]Surface mount inductors

Inductor Manufacturers

Coiltronics Intl.	Pompano Beach, FL, USA	407-241-7876	FAX: 407-241-9339
Sumida	Arlington Heights, IL, USA	708-956-0666	FAX: 708-956-0702
Coilcraft	Cary, IL, USA	800-322-2645	FAX: 708-639-1469

Capacitor Manufacturers

Best: TPS Series	AVX	Myrtle Beach, SC, USA	803-946-0690
Better: OS-CON Series	Sanyo Video	San Diego, CA, USA	619-661-6322
Good: PL Series	Nichicon America	Schaumburg, IL, USA	708-843-7500

Device Pinouts

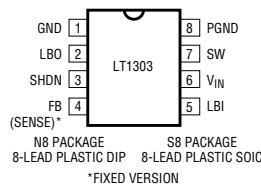
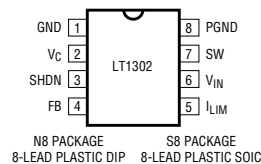
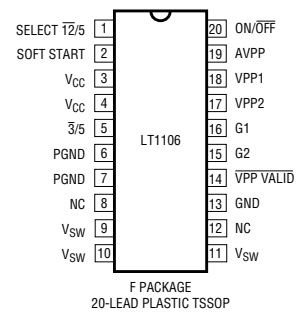
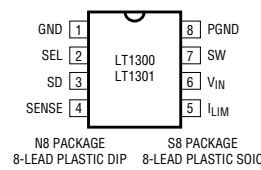
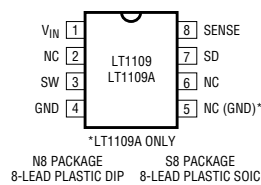
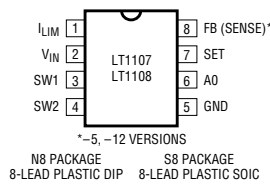

Linear Technology Micropower DC/DC Converter Family

DEVICE	V _{IN} (MIN)	V _{IN} (MAX)	I _{sw} (A) (MAX)	STEP-UP	STEP-DOWN	I _Q (μA)	S/D	LOW BATT DETECT	DROPOUT VOLTAGE (V)	3.3V OUT	5V OUT	12V OUT	ADJ	# OF PINS	SO PACK	APPLICATION EXAMPLE
LT1073	1	15	1	X	X	95		X			X	X	X	8	X	1 Cell to 5V, 40mA
LT1107	2	30	1	X	X	300		X			X	X	X	8	X	2 Cells to 5V, 150mA
LT1108	2	30	1	X	X	110		X			X	X	X	8	X	2 Cells to 5V, 150mA
LT1109	2	30	0.5	X		320					X	X	X	3, 8	X	5V to 12V VPP, 60mA (Flash Memory)
LT1109A	2	20	1	X		320					X	X	X	8	X	5V to 12V VPP, 120mA (Flash Memory)
LT1110	1	15	1	X	X	350		X			X	X	X	8	X	1 Cell to 5V, 40mA
LT1111	2	30	1	X	X	300		X			X	X	X	8	X	2 Cells to 5V, 90mA
LTC1142	6	16	Ext.		X	320	X		0	X	X			16	X	6-8 Cell to both 5V and 3.3V
LTC1142HV	6	20	Ext.		X	320	X		0	X	X			28	X	8-10 Cell NiCad to 5V and 3.3V
LTC1143	6	16	Ext.		X	320	X		0	X	X			28	X	6-8 Cell to both 5V and 3.3V
LTC1147	6	16	Ext.		X	160	X		0	X	X			8	X	6-8 Cell NiCd to 5V or 3.3V @ 1A+
LTC1148	6	16	Ext.		X	160	X		0	X	X		X	14	X	6-8 Cell NiCd to 5V or 3.3V @ 2A
LTC1148HV	6	20	Ext.		X	160	X		0	X	X		X	14	X	8-10 Cell NiCd to 5V or 3.3V @ 2A
LTC1149	7	48	Ext.		X	600	X		2	X	X		X	16	X	≥ 8 Cell NiCd to 5V or 3.3V @ 2A
LT1173	2	30	1	X	X	110		X			X	X	X	8	X	2 Cells to 5V, 90mA
LTC1174	4	13.5	0.6		X	450	X	X	0.5	X	X		X	8	X	9V to 5V @ up to 400mA
LT1300	2	6	1	X		120	X			X	X			8	X	2 Cells to 3.3V or 5V @ 250mA
LT1301	2	6	1	X		120	X				X	X		8	X	2 Cells to 5V or 12V @ 220mA or 50mA
LT1302	2	10	2	X		200	X						X	8	X	2 Cell to 5V at 600mA
LT1303	2	6	1	X		120	X	X			X		X	8	X	2 Cell to 5V @ 220mA
LTC1574	4	16	0.6		X	450	X	X	X	X	X		X	16	X	9V to 5V @ up to 400mA. No External Schottky Diode Needed.