

DUAL SCHMITT TRIGGER
TRIPLE DIFFERENTIAL AMPLIFIER

MECL II MC1000/1200 series

MC1035
MC1235

Three differential amplifiers with emitter-follower outputs and a bias driver. This device is designed for use as a dual Schmitt trigger or a level translator, as well as for many linear applications.

POSITIVE LOGIC

DUAL SCHMITT TRIGGER

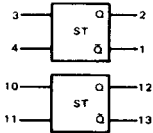

TRIPLE DIFFERENTIAL AMPLIFIER

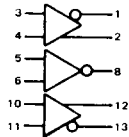

TRUTH TABLE

Inputs		Outputs	
3	4	1	2
5	6	8	7
10	11	13	12
H	V _{BB}	L	H
L	V _{BB}	H	L
V _{BB}	H	H	L
V _{BB}	L	L	H

□ OR ▨ NOR

DC Input Loading Factor = 1
DC Output Loading Factor = 25
Power Dissipation = 140 mW typical

The output polarities shown in the logic diagrams above are true only when V_{BB} is applied on Pins 4, 6 and 11.

CIRCUIT SCHEMATIC

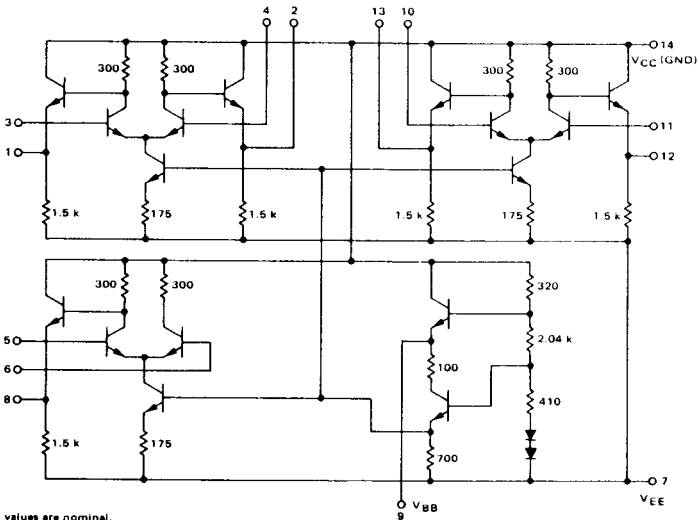

Resistor values are nominal.

236

236

MC1035, MC1235 (continued)

ELECTRICAL CHARACTERISTICS

The output polarity shown in the logic diagram at the right is true only when V_{BB} is applied on pins 4, 6, and 11.

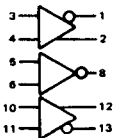

Characteristic	Symbol	Pin Under Test	MC1235 Test Limits						MC1035 Test Limits							
			-55°C		+25°C		+125°C		0°C		+25°C		+75°C		Unit	
			Min	Max	Min	Max	Min	Max	Min	Max	Min	Max	Min	Max		
Power Supply Drain Current	I_D	7	-	-	-	33	-	-	mAdc	-	-	-	33	-	-	mAdc
Input Current	I_{in}	3	-	-	-	100	-	-	μ Adc	-	-	-	100	-	-	μ Adc
		4	-	-	-	-	-	-	-	-	-	-	-	-	-	-
		5	-	-	-	-	-	-	-	-	-	-	-	-	-	-
		6	-	-	-	-	-	-	-	-	-	-	-	-	-	-
		10	-	-	-	-	-	-	-	-	-	-	-	-	-	-
Input Leakage Current	I_{R}	3	-	-	-	0.2	-	1.0	μ Adc	-	-	-	0.2	-	1.0	μ Adc
		4	-	-	-	-	-	-	-	-	-	-	-	-	-	-
		5	-	-	-	-	-	-	-	-	-	-	-	-	-	-
		6	-	-	-	-	-	-	-	-	-	-	-	-	-	-
		10	-	-	-	-	-	-	-	-	-	-	-	-	-	-
"NOR" Logical "1" Output Voltage	V_{OH}^{\dagger}	1	-0.990	-0.825	-0.850	-0.700	-0.700	-0.530	Vdc	-0.895	-0.740	-0.850	-0.700	-0.775	-0.615	Vdc
		8	-	-	-	-	-	-	-	-	-	-	-	-	-	-
		13	-	-	-	-	-	-	-	-	-	-	-	-	-	-
"NOR" Logical "0" Output Voltage	V_{OL}	1	-1.890	-1.580	-1.800	-1.500	-1.720	-1.380	Vdc	-1.830	-1.525	-1.800	-1.500	-1.760	-1.435	Vdc
		8	-	-	-	-	-	-	-	-	-	-	-	-	-	-
		13	-	-	-	-	-	-	-	-	-	-	-	-	-	-
"OR" Logical "1" Output Voltage	V_{OH}^{\dagger}	2	-0.990	-0.825	-0.850	-0.700	-0.700	-0.530	Vdc	-0.895	-0.740	-0.850	-0.700	-0.775	-0.615	Vdc
		8	-	-	-	-	-	-	-	-	-	-	-	-	-	-
		12	-	-	-	-	-	-	-	-	-	-	-	-	-	-
"OR" Logical "0" Output Voltage	V_{OL}	2	-1.890	-1.580	-1.800	-1.500	-1.720	-1.380	Vdc	-1.830	-1.525	-1.800	-1.500	-1.760	-1.435	Vdc
		8	-	-	-	-	-	-	-	-	-	-	-	-	-	-
		12	-	-	-	-	-	-	-	-	-	-	-	-	-	-
Bias Driver Output Voltage	$V_{BB} \textcircled{1}$	9	-1.35	-1.20	-1.26	-1.10	-1.11	-0.98	Vdc	-1.28	-1.14	-1.26	-1.10	-1.19	-1.04	Vdc
Switching Times			Typ	Max	Typ	Max	Typ	Max		Typ	Max	Typ	Max	Typ	Max	
Propagation Delay	t_{3+1-}	1	4.0	8.0	5.0	8.0	6.0	9.0	ns	4.0	8.0	5.0	8.0	5.0	8.5	ns
		1	-	7.0	4.0	7.0	5.0	8.0	-	7.0	4.0	7.0	4.0	7.5	-	
	t_{3+2-}	2	-	7.0	4.0	7.0	5.5	8.0	-	7.0	4.0	7.0	4.0	7.5	-	
		2	-	8.0	5.0	8.0	6.0	9.0	-	8.0	5.0	8.0	5.0	8.5	-	
Rise Time	t_{1+}	1	-	7.0	4.0	7.0	5.0	8.0	-	7.0	4.0	7.0	4.0	7.5	-	
		2	-	7.0	4.0	7.0	5.0	8.0	-	7.0	4.0	7.0	4.0	7.5	-	
Fall Time	t_{1-}	1	5.0	9.0	6.0	9.0	8.0	11	-	5.0	9.0	6.0	9.0	7.0	10	-
		2	5.0	9.0	6.0	9.0	8.0	11	-	5.0	9.0	6.0	9.0	7.0	10	-

$\textcircled{1} V_{BB}$ supplied from pin 9, and is applicable from a load of 0 mA to -1.0 mA. $\dagger V_{OH}$ limits apply from no load (0 mA) to full load (-2.5 mA).

SWITCHING TIME TEST CIRCUIT @ 25°C

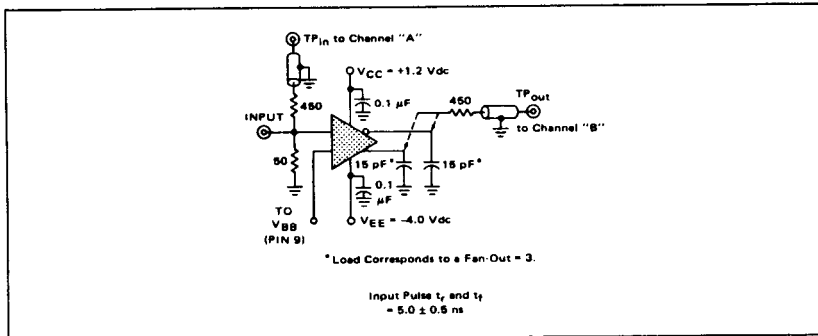

		TEST VOLTAGE/CURRENT VALUES							mAdc
@ Test Temperature		Vdc ± 1.0%							
		V _{IL min} to V _{IL max}	V _{IH min} to V _{IH max}	V _{IH max}	V _{EE}	V _{BB}	I _L		
MCI235	-55°C	-5.2 to -1.405	-1.165 to -0.825	-	5.2	1	2.5		
	+25°C	-5.2 to -1.325	-1.025 to -0.700	0.700	5.2	1	2.5		
	+125°C	-5.2 to -1.205	-0.875 to -0.530	-	5.2	1	2.5		
MCI035	0°C	-5.2 to -1.350	-1.070 to -0.740	-	5.2	1	2.5		
	+25°C	-5.2 to -1.325	-1.025 to -0.700	0.700	5.2	1	2.5		
	+75°C	-5.2 to -1.260	-0.950 to -0.615	-	5.2	1	2.5		

		TEST VOLTAGE/CURRENT APPLIED TO PINS LISTED BELOW:							V _{CC} (Gnd)
Characteristic	Symbol	Pin Under Test	V _{IL min} to V _{IL max}	V _{IH min} to V _{IH max}	V _{IH max}	V _{EE}	V _{BB}	I _L	
Power Supply Drain Current	I _E	7	-	-	-	7	3.5, 10	14	
Input Current	I _{in}	3	-	-	3	6.7, 11	4.5, 10	14	
		4	-	-	4	6.7, 11	3.5, 10	-	
		5	-	-	5	4.7, 11	3.6, 10	-	
		6	-	-	6	4.7, 11	3.5, 10	-	
		10	-	-	10	4.6, 10	3.5, 11	-	
Input Leakage Current	I _R	3	-	-	-	3.6, 7, 11	4.5, 10	14	
		4	-	-	-	4.6, 7, 11	3.5, 10	-	
		5	-	-	-	4.5, 7, 11	3.6, 10	-	
		6	-	-	-	4.6, 7, 11	3.5, 10	-	
		10	-	-	-	4.6, 7, 10	3.5, 11	-	
"NOR" Logical "1" Output Voltage	V _{OH} ¹	1	3	-	-	5.7, 10	4.6, 11	1 14	
		8	5	-	-	3.7, 10	1 8	14	
		13	10	-	-	3.5, 7	1 13	14	
"NOR" Logical "0" Output Voltage	V _{OL}	1	-	3	-	5.7, 10	4.6, 11	1 14	
		8	-	5	-	3.7, 10	1 8	14	
		13	-	10	-	3.5, 7	1 13	14	
"OR" Logical "1" Output Voltage	V _{OH} ¹	2	-	3	-	6.7, 10	4.5, 11	2 14	
		8	-	6	-	3.7, 10	1 8	14	
		12	-	10	-	3.6, 7	1 12	14	
"OR" Logical "0" Output Voltage	V _{OL}	2	3	-	-	6.7, 10	4.5, 11	2 14	
		8	6	-	-	3.7, 10	1 8	14	
		12	10	-	-	3.6, 7	1 12	14	
Bias Driver Output Voltage	V _{BB} ¹	9	-	-	-	7	3.5, 10	14	
Switching Times	Propagation Delay	t ₃₋₁₋	Pulse In		Pulse Out		6.7, 10	4.5, 11	(-1.2 V)
			3	1	-	-			
		t ₃₋₁₊	1	1	-	-			
			2	2	-	-			
		t ₃₋₂₋	2	2	-	-			
			2	2	-	-			
	Rise Time	t ₁₊	1	1	-	-			
		t ₂₊	2	2	-	-			
	Fall Time	t ₁₋	1	1	-	-			
		t ₂₋	2	2	-	-			

SWITCHING TIME WAVEFORMS

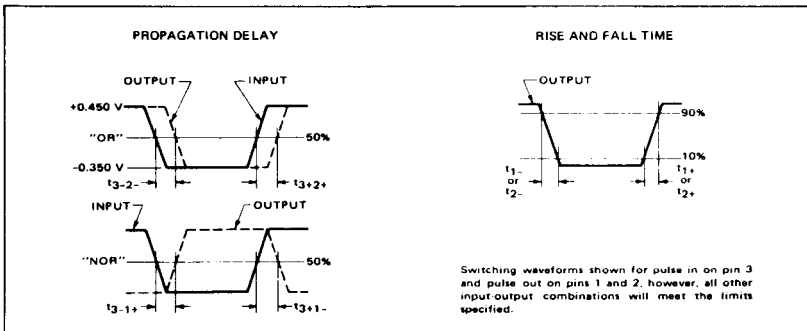

APPLICATIONS INFORMATION

The MC1035/MC1235 is a dual Schmitt trigger/triple differential amplifier designed for interfacing into a MECL system. Signals with very slow rise and fall times and with low voltage swings can be converted to MECL signal levels with MECL rise and fall times to operate flip-flops and gates (see Figures 1 and 2). The circuit also acts as a triple level translator from negative power supply logic circuits, such as those used in PNP discrete component systems and MOS systems, to MECL levels (Figure 3).

The differential inputs allow a threshold of V_{BB} (obtained by connecting the internal V_{BB} reference voltage available at pin 9 to one side of the differential pair) or some other value (externally generated) to be set for the switching point. The externally-generated reference should lie between -0.5 Vdc and a value no more negative than 1.7 volts above V_{EE} . This permits a 3.0-volt range over which the input voltage may vary without affecting the characteristics of the device when using the nominal supply voltage of -5.2 Vdc.

Some of the general properties of the MC1035/MC1235 for each of the three amplifiers are:

Voltage gain - 6.0 V/V (single-ended) or 12 V/V (differential)

Bandwidth (at the 3.0 dB point) - 45 to 50 MHz

Useful gain - to 100 MHz

Common mode rejection ratio - ≈ 80 dB

The amplifiers may be cascaded in various combinations for different gains. A typical gain of 60 dB with an overall bandwidth of 40 MHz can be realized by cascading amplifiers. This makes it useful as an RF/IF amplifier and limiter as shown in Figure 4, or as a wideband video amplifier as shown in Figures 5 and 6. The common-mode rejection ratio in this configuration is typically 80 dB due to the differential-pair emitters.

The active current source in the differential-pair emitters reduces the effects of saturation so that input levels more positive than maximum MECL logic "1" levels can be applied before

saturation occurs. This effect can be seen in Figure 7. Notice also in Figure 7 that the "NOR" logic "0" transfer characteristics do not exhibit the normal droop as the input is made more positive.

Figures 8 through 12 illustrate additional applications for the MC1035/MC1235 as an A/D comparator (Figure 8), a zero crossing detector (Figure 9), a low-current power supply buffer amplifier (Figure 10), and a V_{BB} buffered supply (Figures 11 and 12).

FIGURE 1 - DUAL SCHMITT TRIGGER

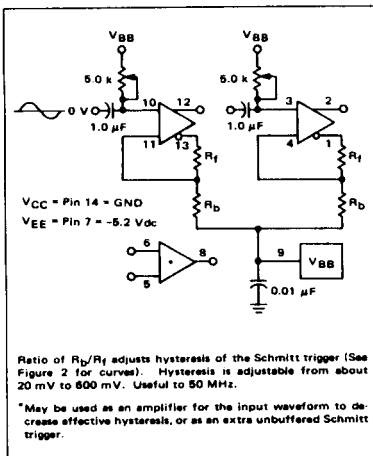

FIGURE 2 - HYSTERESIS CURVES FOR DUAL SCHMITT TRIGGER

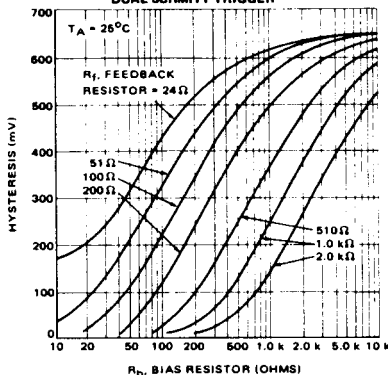
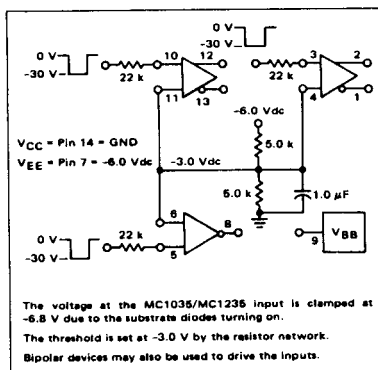

FIGURE 3 - TRIPLE MOS-TO-MECL TRANSLATOR



MC1035, MC1235 (continued)

APPLICATIONS INFORMATION (continued)

FIGURE 4 - RF AMPLIFIER/FM AMPLIFIER-LIMITER

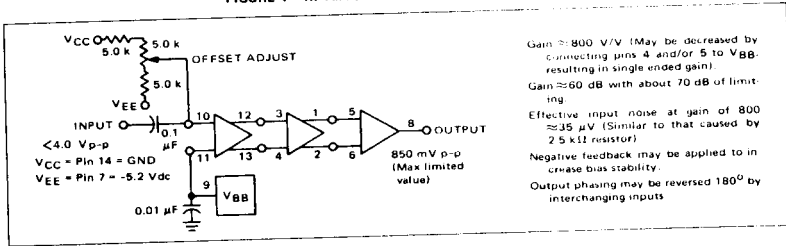

FIGURE 5 - WIDEBAND VIDEO AMPLIFIER WITH BIAS FEEDBACK

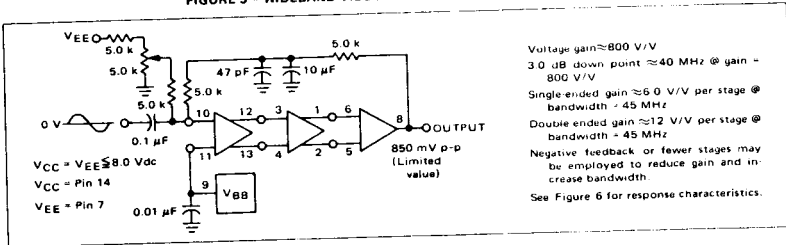

FIGURE 6 - VIDEO AMPLIFIER RESPONSE CHARACTERISTICS

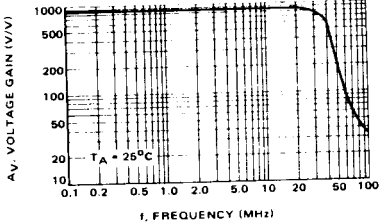

FIGURE 7 - MC1035/MC1235 TRANSFER CHARACTERISTICS

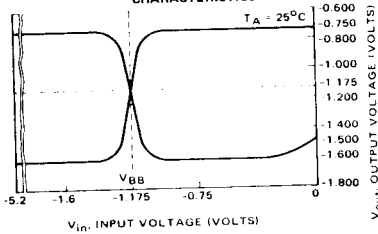
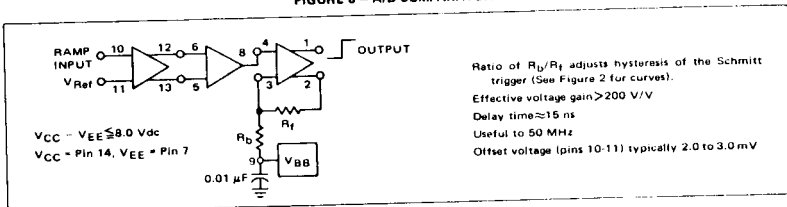

FIGURE 8 - A/D COMPARATOR



MC1035, MC1235 (continued)

APPLICATIONS INFORMATION (continued)

FIGURE 9 - ZERO CROSSING DETECTOR

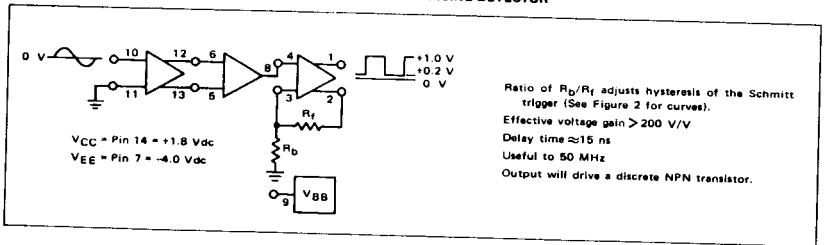

FIGURE 10 - LOW CURRENT POWER SUPPLY BUFFER AMPLIFIER

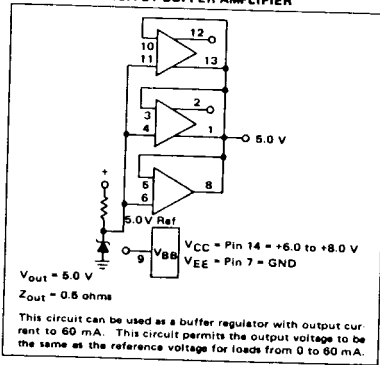

FIGURE 11 - V_{BB} BUFFERED SUPPLY

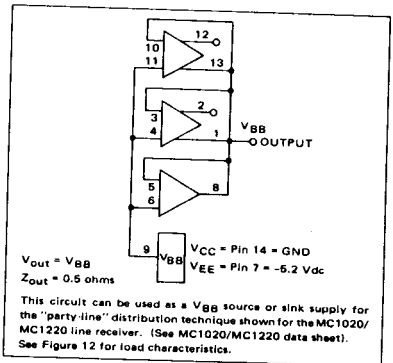
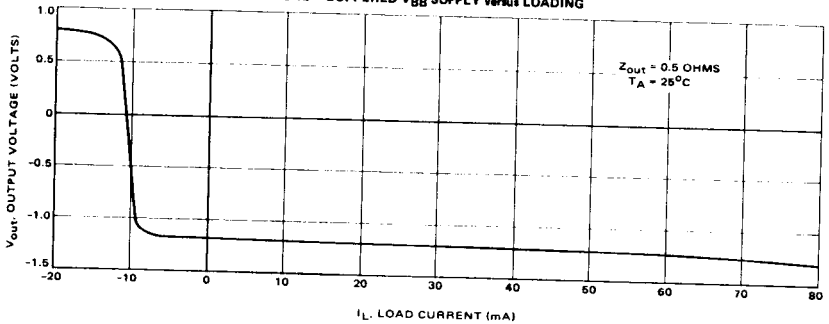

FIGURE 12 - BUFFERED V_{BB} SUPPLY versus LOADING



241