



**AWT6171R**  
 GSM850/GSM900/DCS/PCS  
 Quad Band Power Amplifier Module  
 With Integrated Power Control  
**PRELIMINARY DATA SHEET - Rev 1.0**

**FEATURES**

- Integrated Vreg (regulated supply)
- Harmonic Performance  $\leq -20$  dBm
- High Efficiency (PAE) at Pmax:
  - GSM850, 54 %
  - GSM900, 55 %
  - DCS, 52 %
  - PCS, 52 %
- +34.5 dBm GSM850/900 Output Power at 3.5 V
- +31.5 dBm DCS/PCS Output Power at 3.5 V
- 55 dB Dynamic Range
- GPRS Class 12 Capable
- RoHS Compliant Package, 250°C MSL-3

**APPLICATIONS**

- Dual/Tri/Quad Band Handsets & PDAs

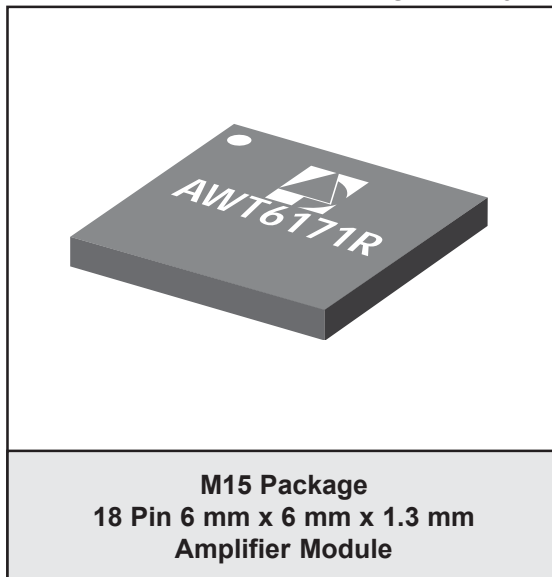

**PRODUCT DESCRIPTION**

As with previous generations, the AWT6171R integrated CMOS power control scheme simplifies the design of the transmitter by eliminating the need for external power control circuitry.

RF outputs, reducing the number of external components required in the final application. Both PA die, GSM850/900 and DCS/PCS, are fabricated using state of the art InGaP HBT technology, known for its proven reliability and temperature stability.

The AWT6171R input and output terminals are internal matched to 50 ohms and DC blocked at the

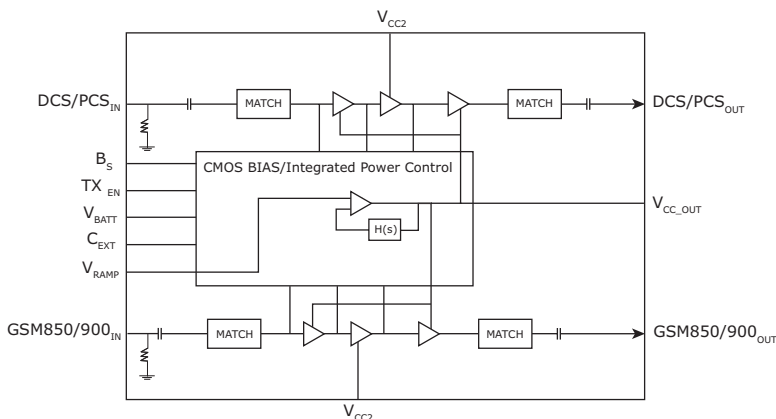

**Figure 1: Block Diagram**

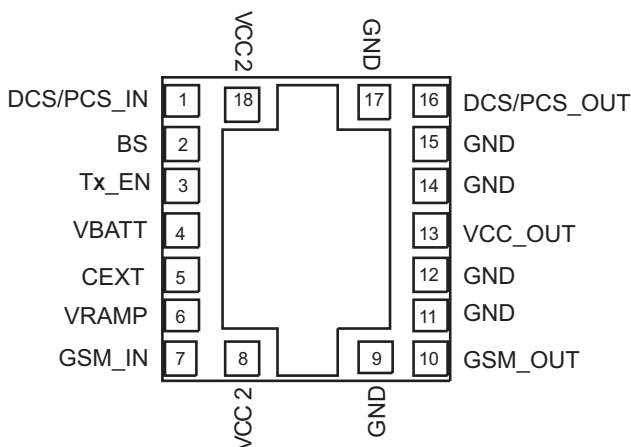

Figure 2: Pinout (X-ray Top View)

Table 1: Pin Description

PIN	NAME	DESCRIPTION	PIN	NAME	DESCRIPTION
1	DCS/PCS_IN	DCS/PCS RF Input	10	GSM_OUT	GSM850/900 RF Output
2	BS	Band Select Logic Input	11	GND	Ground
3	Tx_EN	TX Enable Logic Input	12	GND	Ground
4	V <sub>BATT</sub>	Battery Supply Connection	13	V <sub>CC_OUT</sub>	Control Voltage Output which must be connected to V <sub>CC2</sub>
5	C <sub>EXT</sub>	Bypass	14	GND	Ground
6	V <sub>RAMP</sub>	Analog Signal used to control the output power	15	GND	Ground
7	GSM_IN	GSM850/900 RF Input	16	DCS/PCS_OUT	DCS/PCS RF Output
8	V <sub>CC2</sub>	VCC Control Input for GSM850/900 Pre-amplifier	17	GND	Ground
9	GND	Ground	18	V <sub>CC2</sub>	Vcc Control Input for DCS/PCS Pre-amplifier

## ELECTRICAL CHARACTERISTICS

Table 2: Absolute Minimum and Maximum Ratings

PARAMETER	MIN	MAX	UNIT
Supply Voltage ( $V_{BATT}$ )	-	+7	V
RF Input Power ( $RF_{IN}$ )	-	11	dBm
Control Voltages ( $V_{RAMP}$ )	-0.3	1.8	V
Storage Temperature ( $T_{STG}$ )	- 55	150	°C

Stresses in excess of the absolute ratings may cause permanent damage. Functional operation is not implied under these conditions. Exposure to absolute ratings for extended periods of time may adversely affect reliability.

Table 3: ESD Ratings

PARAMETER	METHOD	RATING	UNIT
ESD Threshold voltage (RF ports)	HBM	>2.5	kV
ESD Threshold voltage (control inputs)	HBM	>2.5	kV

Although protection circuitry has been designed into this device, proper precautions should be taken to avoid exposure to electrostatic discharge (ESD) during handling and mounting. Human body model HBM employed is resistance = 1500  $\Omega$ , capacitance = 100 pF.

Table 4: Digital Inputs

PARAMETER	MIN	TYP	MAX	UNIT
Logic High Voltage ( $V_{IH}$ )	1.2	-	3.0	V
Logic Low Voltage ( $V_{IL}$ )	-	-	0.5	V
Logic High Current ( $I_{IH}$ )	-	-	30	$\mu$ A
Logic Low Current ( $I_{IL}$ )	-	-	30	$\mu$ A

Table 5: Control Logic Table

MODE	Tx_EN	BS
PA Enable	HIGH	X
GSM850/900 Mode	HIGH	LOW
DCS/PCS Mode	HIGH	HIGH
PA Disable	LOW	X

Table 6: Operating Ranges

PARAMETER	MIN	TYP	MAX	UNIT	COMMENTS
Case Temperature ( $T_C$ )	-20	-	85	°C	
Supply Voltage ( $V_{BATT}$ )	3.0	3.5	4.8	V	
Power Supply Leakage Current	-	1	10	$\mu$ A	$V_{BATT} = 4.8$ V, $V_{RAMP} = 0$ V, $TX\_EN = LOW$ , No RF applied
Control Voltage Range	0.2	-	1.6	V	
Turn on time ( $T_{ON}$ )	-	-	1	$\mu$ s	$V_{RAMP} = 0.2$ V, $TX\_EN =$ LOW $\rightarrow$ High $P_{IN} = 5$ dBm
Turn off time ( $T_{OFF}$ )	-	-	1	$\mu$ s	$V_{RAMP} = 0.2$ V, $TX\_EN =$ HIGH $\rightarrow$ LOW $P_{IN} = 5$ dBm
Rise Time ( $T_{RISE}$ )	-	-	1	$\mu$ s	$P_{OUT} = -10$ dBm $\rightarrow P_{MAX}$ (within 0.2 dB)
Fall Time ( $T_{FALL}$ )	-	-	1	$\mu$ s	$P_{OUT} = P_{MAX} \rightarrow -10$ dBm (within 0.2 dB)
$V_{RAMP}$ Input Capacitance	-	3	-	pF	
$V_{RAMP}$ Input Current	-	-	10	$\mu$ A	
Duty Cycle	-	-	50	%	

The device may be operated safely over these conditions; however, parametric performance is guaranteed only over the conditions defined in the electrical specifications.

**Table 7: Electrical Characteristics for GSM850**

Unless otherwise stated ( $V_{BATT} = 3.5$  V,  $P_{IN} = 3.0$  dBm, Pulse Width = 1154  $\mu$ s, Duty 25%,  
 $Z_{IN} = Z_{OUT} = 50$   $\Omega$ ,  $T_C = 25$   $^{\circ}$ C,  $V_{RAMP} = 1.6$  V, BS = LOW, TX\_EN = HIGH)

PARAMETER	MIN	TYP	MAX	UNIT	COMMENTS
Operating Frequency ( $F_o$ )	824	-	849	MHz	
Input Power	0	3.0	5	dBm	
Output Power, $P_{MAX}$	34.0	34.8	-	dBm	Freq = 824 to 849 MHz
Degraded Output Power	32.0	32.8	-	dBm	$V_{BATT} = 3.0$ V, $T_C = 85$ $^{\circ}$ C, $P_{IN} = 0$ dBm
PAE @ $P_{MAX}$	48	54	-	%	Freq = 824 to 849 MHz
Forward Isolation 1	-	-43	-35	dBm	TX_EN = LOW, $V_{RAMP} = 0.2$ V $P_{IN} = 5$ dBm,
Forward Isolation 2	-	-24	-17	dBm	TX_EN = HIGH, $V_{RAMP} = 0.2$ V, $P_{IN} = 5$ dBm
Cross Isolation ( $2F_o$ , $3F_o$ @ DCS/PCS Port)	-	-28	-20	dBm	$P_{OUT} \leq 34.0$ dBm
Harmonics 2fo, 3fo $n * F_o$ , ( $n \geq 4$ ), $F_o \leq 12.75$ GHz	- -	-27 -30	-10 -10	dBm	$P_{OUT} \leq 34.0$ dBm
Stability	VSWR = 8:1 All Phases, $P_{OUT} \leq 34.0$ dBm				
	-	-	-36	dBm	$F_{OUT} < 1$ GHz
	-	-	-30	dBm	$F_{OUT} > 1$ GHz
Ruggedness	-	-	10:1	VSWR	All load phases, $P_{OUT} \leq 34.0$ dBm
RX Noise Power	-	-87	-83	dBm	$F_{TX} = 849$ MHz, RBW = 100 kHz, $F_{RX} = 869$ to 894 MHz, $P_{OUT} \leq 34.0$ dBm
Input VSWR	-	1.5:1	2.5:1	-	$P_{OUT} \leq 34.0$ dBm

**Table 8: Electrical Characteristics for GSM900**

Unless otherwise stated ( $V_{BATT} = 3.5\text{ V}$ ,  $P_{IN} = 3.0\text{ dBm}$ , Pulse Width = 1154  $\mu\text{s}$ , Duty 25%,  
 $Z_{IN} = Z_{OUT} = 50\ \Omega$ ,  $T_C = 25\ ^\circ\text{C}$ ,  $V_{RAMP} = 1.6\text{ V}$ , BS = LOW, TX\_EN = HIGH)

PARAMETER	MIN	TYP	MAX	UNIT	COMMENTS
Operating Frequency ( $F_o$ )	880	-	915	MHz	
Input Power	0	3.0	5	dBm	
Output Power, $P_{MAX}$	34.0	34.6	-	dBm	Freq = 880 to 915 MHz
Degraded Output Power	32.0	32.6	-	dBm	$V_{BATT} = 3.0\text{ V}$ , $T_C = 85\ ^\circ\text{C}$ , $P_{IN} = 0\text{ dBm}$
PAE @ $P_{MAX}$	50	55	-	%	Freq = 880 to 915 MHz
Forward Isolation 1	-	-40	-33	dBm	TX_EN = LOW, $V_{RAMP} = 0.2\text{ V}$ $P_{IN} = 5\text{ dBm}$ ,
Forward Isolation 2	-	-24	-17	dBm	TX_EN = HIGH, $V_{RAMP} = 0.2\text{ V}$ , $P_{IN} = 5\text{ dBm}$
Cross Isolation ( $2F_o$ , $3F_o$ @ DCS/PCS Port)	-	-29	-20	dBm	$P_{OUT} \leq 34.0\text{ dBm}$
Harmonics $2f_o$ , $3f_o$ $n \cdot F_o$ , ( $n \geq 4$ ), $F_o \leq 12.75\text{ GHz}$	-	-22	-10	dBm	$P_{OUT} \leq 34.0\text{ dBm}$
Stability	VSWR = 8:1 All Phases, $P_{OUT} \leq 34.0\text{ dBm}$				
	-	-	-36	dBm	$F_{OUT} < 1\text{ GHz}$
	-	-	-30	dBm	$F_{OUT} > 1\text{ GHz}$
Ruggedness	-	-	10:1	VSWR	All load phases, $P_{OUT} \leq 34.0\text{ dBm}$
RX Noise Power	-	-84	-77	dBm	$F_{TX} = 915\text{ MHz}$ , RBW = 100 kHz, $F_{RX} = 925\text{ to }935\text{ MHz}$ , $P_{OUT} \leq 34.0\text{ dBm}$
	-	-87	-83	dBm	$F_{TX} = 915\text{ MHz}$ , RBW = 100 kHz, $F_{RX} = 935\text{ to }960\text{ MHz}$ , $P_{OUT} \leq 34.0\text{ dBm}$
Input VSWR	-	1.5:1	2.5:1	-	$P_{OUT} \leq 34.0\text{ dBm}$

**Table 9: Electrical Characteristics for DCS**

Unless otherwise stated ( $V_{BATT} = 3.5\text{ V}$ ,  $P_{IN} = 3.0\text{ dBm}$ , Pulse Width = 1154  $\mu\text{s}$ , Duty 25%,  
 $Z_{IN} = Z_{OUT} = 50\ \Omega$ ,  $T_C = 25\ ^\circ\text{C}$ ,  $V_{RAMP} = 1.6\text{ V}$ , BS = HIGH, TX\_EN = HIGH)

PARAMETER	MIN	TYP	MAX	UNIT	COMMENTS
Operating Frequency	1710	-	1785	MHz	
Input Power	0	3.0	5	dBm	
Output Power, $P_{MAX}$	31.5	32.2	-	dBm	Freq = 1710 to 1785 MHz
Degraded Output Power	29.5	30.2	-	dBm	$V_{BATT} = 3.0\text{ V}$ , $T_C = 85\ ^\circ\text{C}$ , $P_{IN} = 0\text{ dBm}$
PAE @ $P_{MAX}$	45	52	-	%	Freq = 1710 to 1785 MHz
Forward Isolation 1	-	-38	-33	dBm	TX_EN = LOW, $V_{RAMP} = 0.2\text{ V}$ $P_{IN} = 5\text{ dBm}$ ,
Forward Isolation 2	-	-21	-16	dBm	TX_EN = HIGH, $V_{RAMP} = 0.2\text{ V}$ , $P_{IN} = 5\text{ dBm}$
Harmonics 2fo, 3fo $n \cdot F_o$ , ( $n \geq 4$ ), $F_o \leq 12.75\text{ GHz}$	-	-22	-10	dBm	$P_{OUT} \leq 31.5\text{ dBm}$
Stability	VSWR = 8:1 All Phases, $P_{OUT} \leq 31.5\text{ dBm}$				
	-	-	-36	dBm	$F_{OUT} < 1\text{ GHz}$
	-	-	-30	dBm	$F_{OUT} > 1\text{ GHz}$
Ruggedness	-	-	10:1	VSWR	All load phases, $P_{OUT} \leq 31.5\text{ dBm}$
RX Noise Power	-	-86	-80	dBm	$F_{TX} = 1785\text{ MHz}$ , RBW = 100 kHz, $F_{RX} = 1805\text{ to }1880\text{ MHz}$ , $P_{OUT} \leq 31.5\text{ dBm}$
Input VSWR	-	1.5:1	2.5:1	-	$P_{OUT} \leq 31.5\text{ dBm}$

**Table 10: Electrical Characteristics for PCS**

Unless otherwise stated ( $V_{BATT} = 3.5$  V,  $P_{IN} = 3.0$  dBm, Pulse Width = 1154  $\mu$ s, Duty 25%,  
 $Z_{IN} = Z_{OUT} = 50$   $\Omega$ ,  $T_C = 25$   $^{\circ}$ C,  $V_{RAMP} = 1.6$  V, BS = HIGH, TX\_EN = HIGH)

PARAMETER	MIN	TYP	MAX	UNIT	COMMENTS
Operating Frequency	1850	-	1910	MHz	
Input Power	0	3.0	5	dBm	
Output Power, $P_{MAX}$	31.5	32.0	-	dBm	Freq = 1850 to 1910 MHz
Degraded Output Power	29.5	30.0	-	dBm	$V_{BATT} = 3.0$ V, $T_C = 85$ $^{\circ}$ C, $P_{IN} = 0$ dBm
PAE @ $P_{MAX}$	45	52	-	%	Freq = 1850 to 1910 MHz
Forward Isolation 1	-	-38	-33	dBm	TX_EN = LOW, $V_{RAMP} = 0.2$ V $P_{IN} = 5$ dBm,
Forward Isolation 2	-	-21	-16	dBm	TX_EN = HIGH, $V_{RAMP} = 0.2$ V, $P_{IN} = 5$ dBm
Harmonics 2fo, 3fo $n \cdot F_o$ , ( $n \geq 4$ ), $F_o \leq 12.75$ GHz	- -	-20 -20	-10 -5	dBm	$P_{OUT} \leq 31.5$ dBm
Stability	VSWR = 8:1 All Phases, $P_{OUT} \leq 31.5$ dBm				
	-	-	-36	dBm	$F_{OUT} < 1$ GHz
	-	-	-30	dBm	$F_{OUT} > 1$ GHz
Ruggedness	-	-	10:1	VSWR	All load phases, $P_{OUT} \leq 31.5$ dBm
RX Noise Power	-	-86	-80	dBm	$F_{TX} = 1910$ MHz, RBW = 100 kHz, $F_{RX} = 1930$ to 1990 MHz, $P_{OUT} \leq 31.5$ dBm
Input VSWR	-	1.5:1	2.5:1	-	$P_{OUT} \leq 31.5$ dBm



## APPLICATION INFORMATION

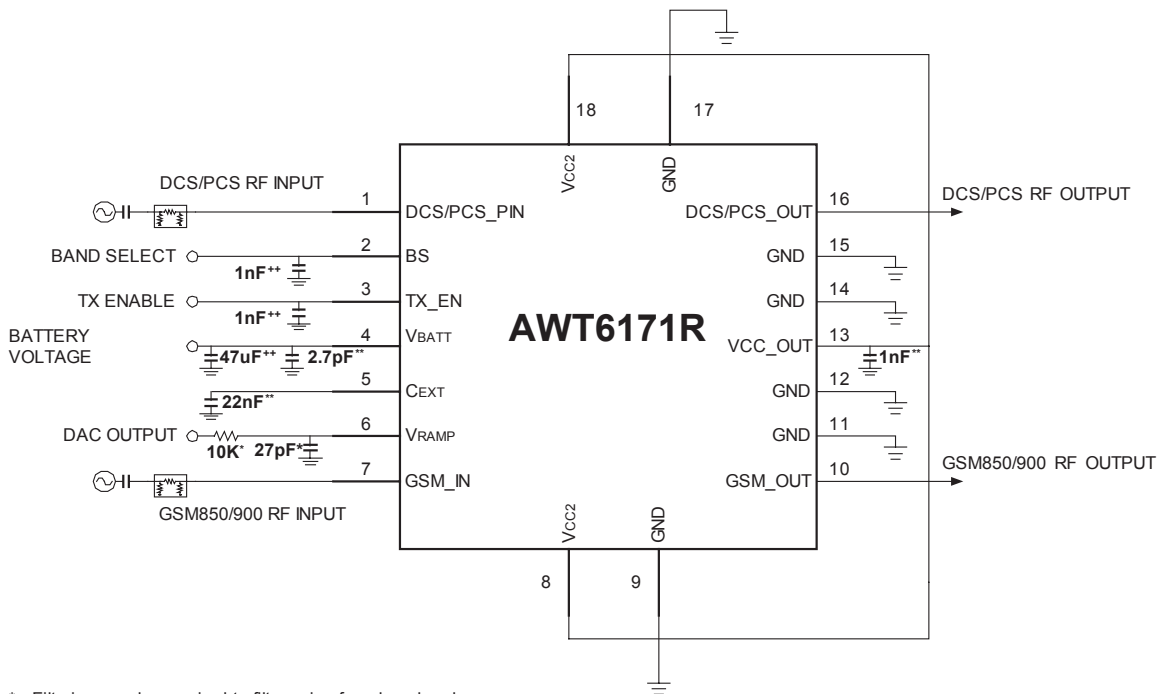

\* Filtering may be required to filter noise from baseband.

\*\* This component should be placed as close to the device pin as possible.

++ These components are recommended as good design practice for improving noise rejection characteristics. The values specified are not critical as they may not be required in the final application.

**Figure 3: Application Schematic**

PACKAGE OUTLINE

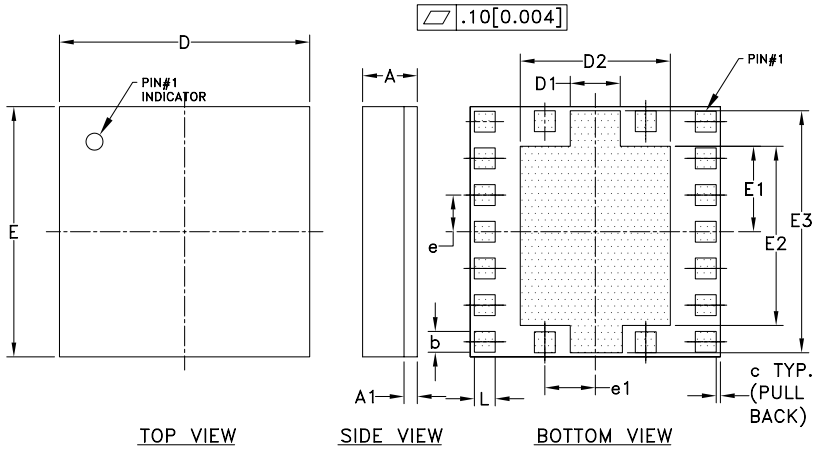

S <sub>NO</sub>	MILLIMETERS			INCHES			NOTE
	MIN.	NOM.	MAX.	MIN.	NOM.	MAX.	
A	1.16	1.31	1.46	0.045	0.051	0.057	—
A1	0.25	0.30	0.38	0.010	0.012	0.015	—
b	0.47	—	0.53	0.019	—	0.021	—
c	—	0.10	—	—	0.004	—	—
D	5.88	6.00	6.12	0.231	0.236	0.240	—
D1	1.13	—	1.25	0.044	—	0.049	—
D2	3.52	—	3.64	0.139	—	0.143	—
E	5.88	6.00	6.12	0.231	0.236	0.240	—
E1	2.02	—	2.08	0.080	—	0.082	—
E2	4.24	—	4.36	0.167	—	0.172	—
E3	5.72	—	5.84	0.225	—	0.230	—
e	—	0.89	—	—	0.035	—	—
e1	—	1.22	—	—	0.048	—	—
L	0.47	—	0.53	0.019	—	0.021	—

NOTES:

1. CONTROLLING DIMENSIONS: MILLIMETERS
2. UNLESS SPECIFIED TOLERANCE=±0.076[0.003].
3. PADS (INCLUDING CENTER) SHOWN UNIFORM SIZE FOR REFERENCE ONLY. ACTUAL PAD SIZE AND LOCATION WILL VARY WITHIN MIN. AND MAX. DIMENSIONS ACCORDING TO SPECIFIC LAMINATE DESIGN.

Figure 4: M15 Package Outline - 18 Pin 6 mm x 6 mm x 1.3 mm Amplifier Module

TOP BRAND

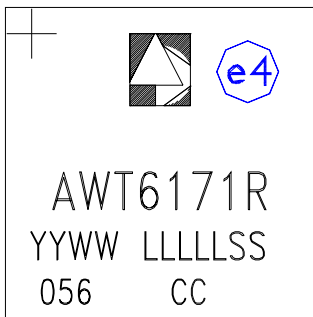

NOTES:

1. ANADIGICS LOGO SIZE: X=0.080±0.010 Y=0.095±0.010
2. PART # AWT6171R
3. YEAR AND WORK WEEK: YYWW: YY = YEAR, WW = WORK WEEK
4. LOT - WAFER I.D.: LLLLL = LOT#(USE U3 LOT#),SS = WAFER I.D.
5. PIN 1 INDICATOR: LASER MARK
6. BOM # 056
7. COUNTRY CODE: CC = TH -for- THAILAND, TW -for- TAIWAN, PH -for- PHILLIPPINES, CH -for- CHINA, ID -for- INDONESIA, HK -for- HONG KONG
8. TYPE : ELITE  
SIZE : AS LARGE AS POSSIBLE

Figure 5: Branding Specification

NOTES

**ORDERING INFORMATION**

ORDER NUMBER	TEMPERATURE RANGE	PACKAGE DESCRIPTION	COMPONENT PACKAGING
AWT6171RM15P8	-20 °C to +85 °C	RoHS Compliant 18 Pin 6 mm x 6 mm x 1.3 mm	Tape and Reel, 2500 per reel

**ANADIGICS, Inc.**

141 Mount Bethel Road  
Warren, New Jersey 07059, U.S.A.  
Tel: +1 (908) 668-5000  
Fax: +1 (908) 668-5132

URL: <http://www.anadigics.com>  
E-mail: [Mktg@anadigics.com](mailto:Mktg@anadigics.com)

**IMPORTANT NOTICE**

ANADIGICS, Inc. reserves the right to make changes to its products or to discontinue any product at any time without notice. The product specifications contained in Advanced Product Information sheets and Preliminary Data Sheets are subject to change prior to a product's formal introduction. Information in Data Sheets have been carefully checked and are assumed to be reliable; however, ANADIGICS assumes no responsibilities for inaccuracies. ANADIGICS strongly urges customers to verify that the information they are using is current before placing orders.

**WARNING**

ANADIGICS products are not intended for use in life support appliances, devices or systems. Use of an ANADIGICS product in any such application without written consent is prohibited.