

### High Speed +5V Powered RS-232 Transmitters/Receivers

The HIN202A and HIN232A high-speed RS-232 transmitter/receiver interface circuits meet all EIA high-speed RS-232E and V.28 specifications, and are particularly suited for those applications where  $\pm 12V$  is not available. They require a single +5V power supply and feature onboard charge pump voltage converters which generate +10V and -10V supplies from the 5V supply.

The drivers feature true TTL/CMOS input compatibility, slew rate-limited output, and 300 $\Omega$  power-off source impedance. The receivers can handle up to  $\pm 30V$  input, and have a 3k $\Omega$  to 7k $\Omega$  input impedance. The receivers also feature hysteresis to greatly improve noise rejection.

### Applications

- Any System Requiring High-Speed RS-232 Communication Ports
  - Computer - Portable, Mainframe, Laptop
  - Peripheral - Printers and Terminals
  - Instrumentation, UPS
  - Modems

### Features

- Meets All RS-232E and V.28 Specifications
- Requires Only 0.1 $\mu F$  or Greater External Capacitors
- High Data Rate. . . . . 230kbit/s
- Requires Only Single +5V Power Supply
- Onboard Voltage Doubler/Inverter
- Low Power Consumption (Typ) . . . . . 5mA
- Multiple Drivers
  - $\pm 10V$  Output Swing for +5V Input
  - 300 $\Omega$  Power-Off Source Impedance
  - Output Current Limiting
  - TTL/CMOS Compatible
- Multiple Receivers
  - $\pm 30V$  Input Voltage Range
  - 3k $\Omega$  to 7k $\Omega$  Input Impedance
  - 0.5V Hysteresis to Improve Noise Rejection

### Ordering Information

| PART NO.     | TEMP. RANGE (°C) | PACKAGE        | PKG. DWG. # |
|--------------|------------------|----------------|-------------|
| HIN202ACBN   | 0 to 70          | 16 Ld SOIC (N) | M16.15      |
| HIN232ACB    | 0 to 70          | 16 Ld SOIC     | M16.3       |
| HIN232ACB-T  | 0 to 70          | Tape and Reel  |             |
| HIN232ACBN   | 0 to 70          | 16 Ld SOIC (N) | M16.15      |
| HIN232ACBN-T | 0 to 70          | Tape and Reel  |             |
| HIN232ACP    | 0 to 70          | 16 Ld PDIP     | E16.3       |

### Selection Table

| PART NUMBER | POWER SUPPLY VOLTAGE | NUMBER OF RS-232 DRIVERS | NUMBER OF RS-232 RECEIVERS | NUMBER OF 0.1 $\mu F$ EXTERNAL CAPACITORS | LOW POWER SHUTDOWN/TTL THREE-STATE | NUMBER OF RECEIVERS ACTIVE IN SHUTDOWN |
|-------------|----------------------|--------------------------|----------------------------|---|------------------------------------|--|
| HIN202A     | +5V                  | 2                        | 2                          | 4 Capacitors                              | No/No                              | 0                                      |
| HIN232A     | +5V                  | 2                        | 2                          | 4 Capacitors                              | No/No                              | 0                                      |

Pinouts

HIN202A (PDIP, SOIC)  
TOP VIEW

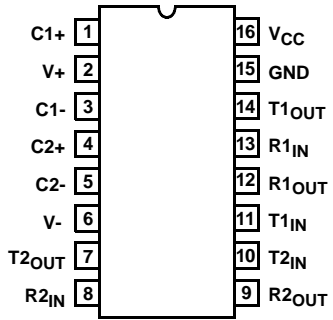

HIN232A (PDIP, SOIC)  
TOP VIEW

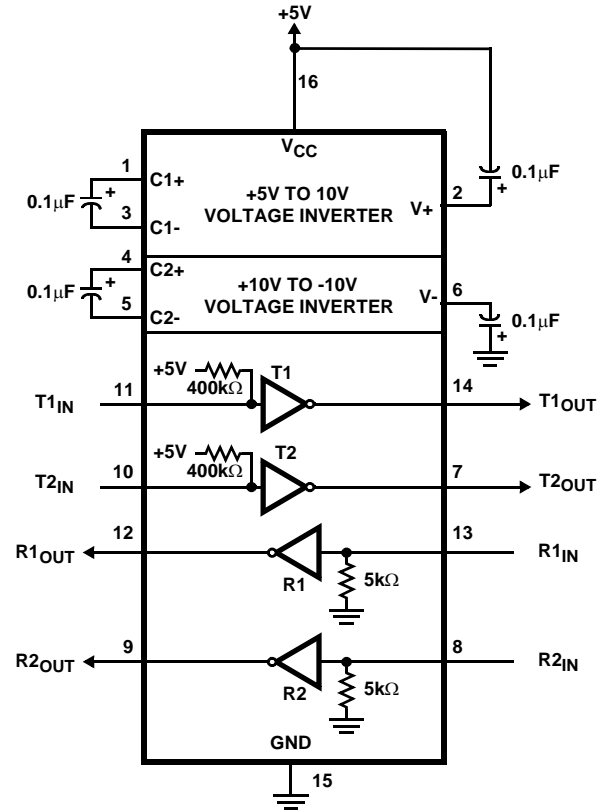
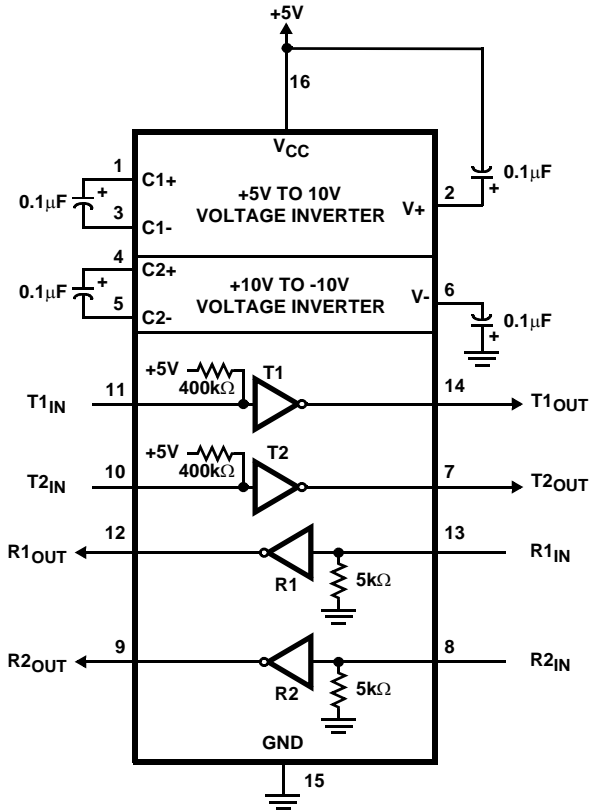
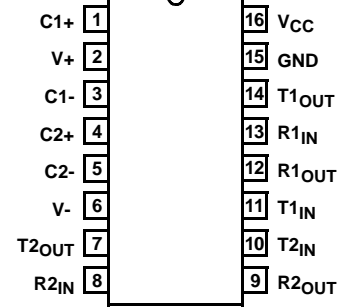

**Pin Descriptions**

| <b>PIN</b>       | <b>FUNCTION</b>  |
|------------------|--|
| V <sub>CC</sub>  | Power Supply Input 5V ±10%.  |
| V+               | Internally generated positive supply (+10V nominal).   |
| V-               | Internally generated negative supply (-10V nominal).   |
| GND              | Ground Lead. Connect to 0V.  |
| C1+              | External capacitor (+ terminal) is connected to this lead.   |
| C1-              | External capacitor (- terminal) is connected to this lead.   |
| C2+              | External capacitor (+ terminal) is connected to this lead.   |
| C2-              | External capacitor (- terminal) is connected to this lead.   |
| T <sub>IN</sub>  | Transmitter Inputs. These leads accept TTL/CMOS levels. An internal 400kΩ pull-up resistor to V <sub>CC</sub> is connected to each lead. |
| T <sub>OUT</sub> | Transmitter Outputs. These are RS-232 levels (nominally ±10V).   |
| R <sub>IN</sub>  | Receiver Inputs. These inputs accept RS-232 input levels. An internal 5kΩ pull-down resistor to GND is connected to each input.          |
| R <sub>OUT</sub> | Receiver Outputs. These are TTL/CMOS levels.   |

# HIN202A, HIN232A

## Absolute Maximum Ratings

|                           |   |
|---------------------------|---|
| V <sub>CC</sub> to Ground | (GND -0.3V) < V <sub>CC</sub> < 6V            |
| V+ to Ground              | (V <sub>CC</sub> -0.3V) < V+ < 12V            |
| V- to Ground              | -12V < V- < (GND +0.3V)                       |
| Input Voltages            |   |
| T <sub>IN</sub>           | -0.3V < V <sub>IN</sub> < (V+ +0.3V)          |
| R <sub>IN</sub>           | ±30V  |
| Output Voltages           |   |
| T <sub>OUT</sub>          | (V- -0.3V) < V <sub>TXOUT</sub> < (V+ +0.3V)  |
| R <sub>OUT</sub>          | (GND -0.3V) < V <sub>RXOUT</sub> < (V+ +0.3V) |
| Short Circuit Duration    |   |
| T <sub>OUT</sub>          | Continuous                                    |
| R <sub>OUT</sub>          | Continuous                                    |
| ESD Classification        | See Specification Table                       |

## Thermal Information

|  |                               |
|--|-------------------------------|
| Thermal Resistance (Typical, Note 1)           | θ <sub>JA</sub> (°C/W)        |
| 16 Ld SOIC (N) Package                         | 110                           |
| 16 Ld SOIC (W) Package                         | 100                           |
| 16 Ld PDIP Package                             | 90                            |
| Maximum Junction Temperature (Plastic Package) | 150°C                         |
| Maximum Storage Temperature Range              | -65°C to 150°C                |
| Maximum Lead Temperature (Soldering 10s)       | 300°C (SOIC - Lead Tips Only) |

## Operating Conditions

|                   |             |
|-------------------|-------------|
| Temperature Range |             |
| HIN2XXCX          | 0°C to 70°C |

**CAUTION:** Stresses above those listed in "Absolute Maximum Ratings" may cause permanent damage to the device. This is a stress only rating and operation of the device at these or any other conditions above those indicated in the operational sections of this specification is not implied.

### NOTE:

1. θ<sub>JA</sub> is measured with the component mounted on a low effective thermal conductivity test board in free air. See Tech Brief TB379 for details.

## Electrical Specifications

Test Conditions: V<sub>CC</sub> = +5V ±10%, C1-C4 = 0.1µF; T<sub>A</sub> = Operating Temperature Range

| PARAMETER  | TEST CONDITIONS   | MIN                                | TYP | MAX | UNITS |    |
|--|---|------------------------------------|-----|-----|-------|----|
| <b>SUPPLY CURRENTS</b>                                   |   |                                    |     |     |       |    |
| Power Supply Current, I <sub>CC</sub>                    | No Load,<br>T <sub>A</sub> = 25°C   | HIN202A                            | -   | 8   | 15    | mA |
|  |   | HIN232A                            | -   | 5   | 10    | mA |
| <b>LOGIC AND TRANSMITTER INPUTS, RECEIVER OUTPUTS</b>    |   |                                    |     |     |       |    |
| Input Logic Low, V <sub>IL</sub>                         | T <sub>IN</sub>   | -                                  | -   | 0.8 | V     |    |
| Input Logic High, V <sub>IH</sub>                        | T <sub>IN</sub>   | 2.0                                | -   | -   | V     |    |
| Transmitter Input Pullup Current, I <sub>p</sub>         | T <sub>IN</sub> = 0V  | -                                  | 15  | 200 | µA    |    |
| TTL/CMOS Receiver Output Voltage Low, V <sub>OL</sub>    | I <sub>OUT</sub> = 3.2mA  | -                                  | 0.1 | 0.4 | V     |    |
| TTL/CMOS Receiver Output Voltage High, V <sub>OH</sub>   | I <sub>OUT</sub> = -1mA   | 3.5                                | 4.6 | -   | V     |    |
| <b>RECEIVER INPUTS</b>                                   |   |                                    |     |     |       |    |
| RS-232 Input Voltage Range, V <sub>IN</sub>              |   | -30                                | -   | +30 | V     |    |
| Receiver Input Impedance, R <sub>IN</sub>                | T <sub>A</sub> = 25°C, V <sub>IN</sub> = ±3V  | 3.0                                | 5.0 | 7.0 | kΩ    |    |
| Receiver Input Low Threshold, V <sub>IN</sub> (H-L)      | V <sub>CC</sub> = 5V,<br>T <sub>A</sub> = 25°C  | Active Mode                        | -   | 1.2 | -     | V  |
|  |   | Shutdown Mode<br>HIN213A R4 and R5 | -   | 1.5 | -     | V  |
| Receiver Input High Threshold, V <sub>IN</sub> (L-H)     | V <sub>CC</sub> = 5V,<br>T <sub>A</sub> = 25°C  | Active Mode                        | -   | 1.7 | 2.4   | V  |
|  |   | Shutdown Mode<br>HIN213A R4 and R5 | -   | 1.5 | 2.4   | V  |
| Receiver Input Hysteresis, V <sub>HYST</sub>             | V <sub>CC</sub> = 5V, No Hysteresis in Shutdown Mode  | 0.2                                | 0.5 | 1.0 | V     |    |
| <b>TIMING CHARACTERISTICS</b>                            |   |                                    |     |     |       |    |
| Transmitter, Receiver Propagation Delay, t <sub>PD</sub> |   | -                                  | 0.5 | 10  | µs    |    |
| Transition Region Slew Rate, SR <sub>T</sub>             | R <sub>L</sub> = 3kΩ, C <sub>L</sub> = 1000pF, Measured from +3V to -3V or -3V to +3V, (Note 2) 1 Transmitter Switching | 3                                  | 20  | 45  | V/µs  |    |
| <b>TRANSMITTER OUTPUTS</b>                               |   |                                    |     |     |       |    |
| Output Voltage Swing, T <sub>OUT</sub>                   | Transmitter Outputs, 3kΩ to Ground  | ±5                                 | ±9  | ±10 | V     |    |
| Output Resistance, T <sub>OUT</sub>                      | V <sub>CC</sub> = V+ = V- = 0V, V <sub>OUT</sub> = ±2V  | 300                                | -   | -   | Ω     |    |
| RS-232 Output Short Circuit Current, I <sub>SC</sub>     | T <sub>OUT</sub> Shorted to GND   | -                                  | ±10 | -   | mA    |    |
| <b>ESD PERFORMANCE</b>                                   |   |                                    |     |     |       |    |
| RS-232 Pins<br>(T <sub>OUT</sub> , R <sub>IN</sub> )     | Human Body Model  | -                                  | ±15 | -   | kV    |    |
|  | IEC1000-4-2 Contact Discharge   | -                                  | ±8  | -   | kV    |    |
|  | IEC1000-4-2 Air Gap (Note 3)  | -                                  | ±15 | -   | kV    |    |

**Electrical Specifications** Test Conditions:  $V_{CC} = +5V \pm 10\%$ ,  $C1-C4 = 0.1\mu F$ ;  $T_A =$  Operating Temperature Range (Continued)

| PARAMETER      | TEST CONDITIONS  | MIN | TYP     | MAX | UNITS |
|----------------|------------------|-----|---------|-----|-------|
| All Other Pins | Human Body Model | -   | $\pm 2$ | -   | kV    |

NOTES:

- Guaranteed by design.
- Meets level 4.

**Test Circuits (HIN232A)**

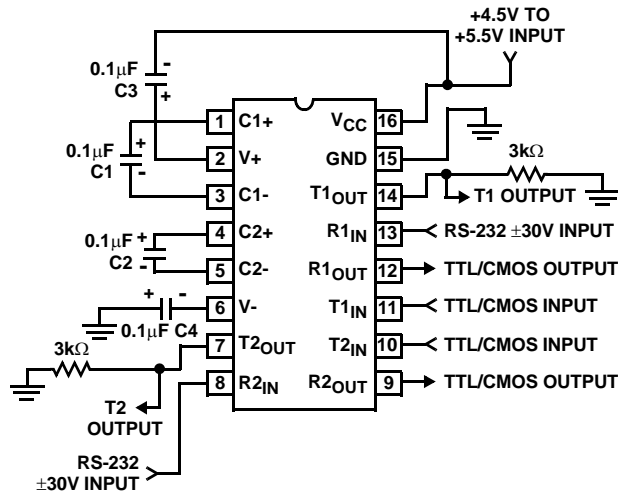

FIGURE 1. GENERAL TEST CIRCUIT

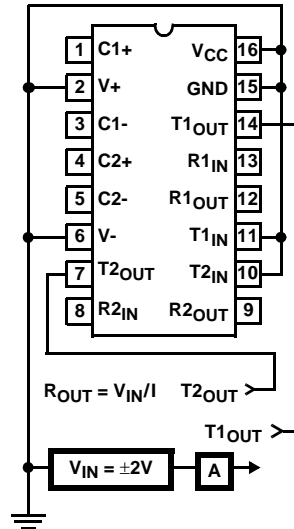

FIGURE 2. POWER-OFF SOURCE RESISTANCE CONFIGURATION

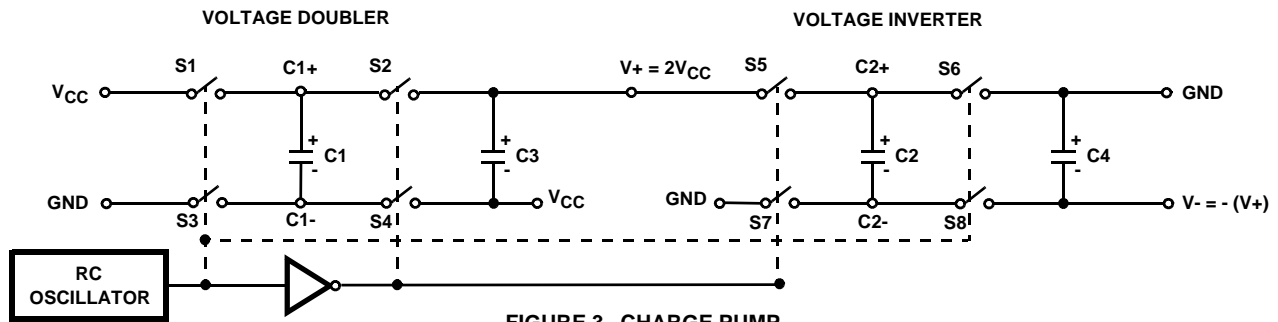

FIGURE 3. CHARGE PUMP

**Detailed Description**

The HIN2XXA family of high-speed RS-232 transmitters/receivers are powered by a single +5V power supply, feature low power consumption, and meet all EIA RS232C and V.28 specifications. The circuit is divided into three sections: the charge pump, transmitter, and receiver.

**Charge Pump**

An equivalent circuit of the charge pump is illustrated in Figure 3. The charge pump contains two sections: The voltage doubler and the voltage inverter. Each section is driven by a two phase, internally generated clock to generate +10V and -10V. The nominal clock frequency is 125kHz. During phase one of the clock, capacitor C1 is

charged to  $V_{CC}$ . During phase two, the voltage on C1 is added to  $V_{CC}$ , producing a signal across C3 equal to twice  $V_{CC}$ . During phase two, C2 is also charged to  $2V_{CC}$ , and then during phase one, it is inverted with respect to ground to produce a signal across C4 equal to  $-2V_{CC}$ . The charge pump accepts input voltages up to 5.5V. The output impedance of the voltage doubler section (V+) is approximately  $200\Omega$ , and the output impedance of the voltage inverter section (V-) is approximately  $450\Omega$ . A typical application uses  $0.1\mu F$  capacitors for C1-C4, however, the value is not critical. Increasing the values of C1 and C2 will lower the output impedance of the voltage doubler and inverter, increasing the values of the reservoir capacitors, C3 and C4, lowers the ripple on the V+ and V- supplies.

**Transmitters**

The transmitters are TTL/CMOS compatible inverters which translate the inputs to RS-232 outputs. The input logic threshold is about 26% of  $V_{CC}$ , or 1.3V for  $V_{CC} = 5V$ . A logic 1 at the input results in a voltage of between -5V and  $V^-$  at the output, and a logic 0 results in a voltage between +5V and  $(V^+ - 0.6V)$ . Each transmitter input has an internal 400k $\Omega$  pullup resistor so any unused input can be left unconnected and its output remains in its low state. The output voltage swing meets the RS-232C specifications of  $\pm 5V$  minimum with the worst case conditions of: all transmitters driving 3k $\Omega$  minimum load impedance,  $V_{CC} = 4.5V$ , and maximum allowable operating temperature. The transmitters have an internally limited output slew rate which is less than 30V/ $\mu s$ . The outputs are short circuit protected and can be shorted to ground indefinitely. The powered down output impedance is a minimum of 300 $\Omega$  with  $\pm 2V$  applied to the outputs and  $V_{CC} = 0V$ .

**Receivers**

The receiver inputs accept up to  $\pm 30V$  while presenting the required 3k $\Omega$  to 7k $\Omega$  input impedance even if the power is off ( $V_{CC} = 0V$ ). The receivers have a typical input threshold of 1.3V which is within the  $\pm 3V$  limits, known as the transition region, of the RS-232 specifications. The receiver output is 0V to  $V_{CC}$ . The output will be low whenever the input is greater than 2.4V and high whenever the input is floating or driven between +0.8V and -30V. The receivers feature 0.5V hysteresis (except during shutdown) to improve noise rejection.

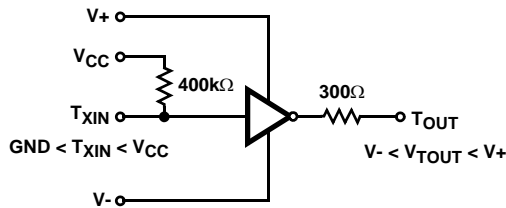

FIGURE 4. TRANSMITTER

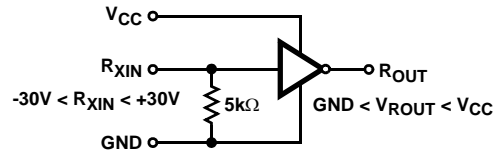

FIGURE 5. RECEIVER

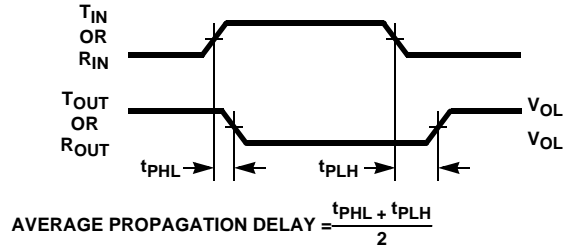

FIGURE 6. PROPAGATION DELAY DEFINITION

**Application Information**

The HIN2XXA may be used for all RS-232 data terminal and communication links. It is particularly useful in applications where  $\pm 12V$  power supplies are not available for conventional RS-232 interface circuits. The applications presented represent typical interface configurations.

A simple duplex RS-232 port with CTS/RTS handshaking is illustrated in Figure 7. Fixed output signals such as DTR (data terminal ready) and DSRS (data signaling rate select) is generated by driving them through a 5k $\Omega$  resistor connected to  $V^+$ .

In applications requiring four RS-232 inputs and outputs (Figure 8), note that each circuit requires two charge pump capacitors (C1 and C2) but can share common reservoir capacitors (C3 and C4). The benefit of sharing common reservoir capacitors is the elimination of two capacitors and the reduction of the charge pump source impedance which effectively increases the output swing of the transmitters.

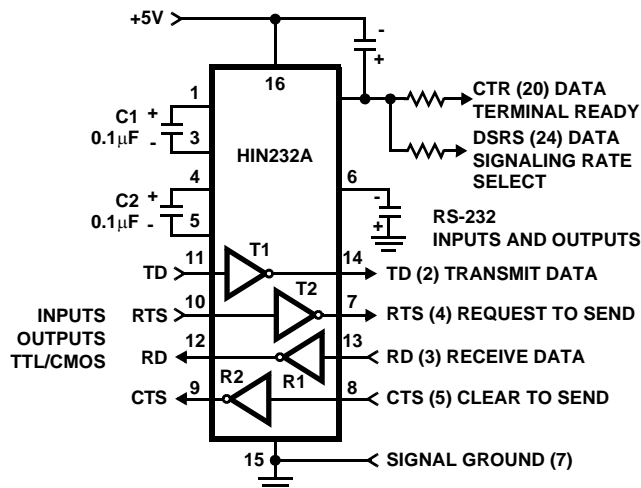

FIGURE 7. SIMPLE DUPLEX RS-232 PORT WITH CTS/RTS HANDSHAKING

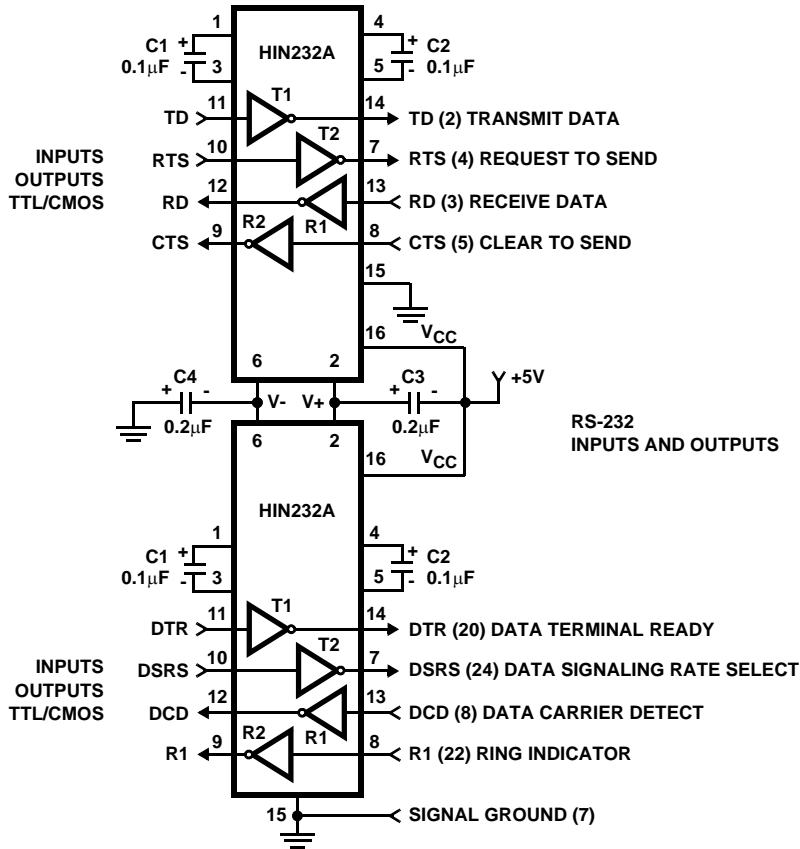

FIGURE 8. COMBINING TWO HIN232As FOR 4 PAIRS OF RS-232 INPUTS AND OUTPUTS

Typical Performance Curves

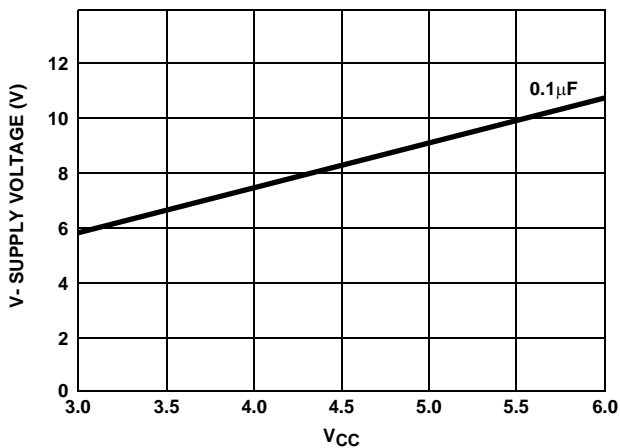

FIGURE 9. V- SUPPLY VOLTAGE vs V<sub>CC</sub>

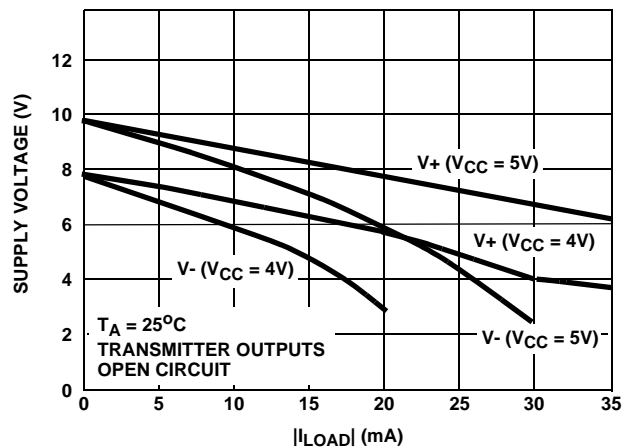

FIGURE 10. V<sub>+</sub>, V<sub>-</sub> OUTPUT VOLTAGE vs LOAD

## **Die Characteristics**

### **DIE DIMENSIONS**

160 mils x 140 mils

### **METALLIZATION**

Type: Al

Thickness:  $10\text{k}\text{\AA} \pm 1\text{k}\text{\AA}$

### **SUBSTRATE POTENTIAL**

V+

### **PASSIVATION**

Type: Nitride over Silox

Nitride Thickness:  $8\text{k}\text{\AA}$

Silox Thickness:  $7\text{k}\text{\AA}$

### **TRANSISTOR COUNT**

238

### **PROCESS**

CMOS Metal Gate



Dual-In-Line Plastic Packages (PDIP)

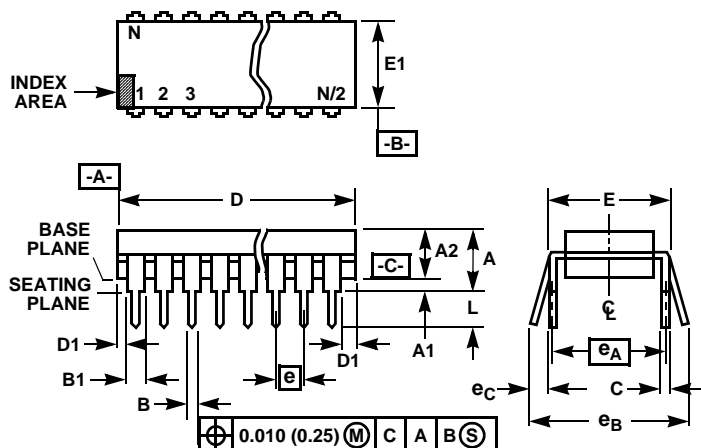

NOTES:

1. Controlling Dimensions: INCH. In case of conflict between English and Metric dimensions, the inch dimensions control.
2. Dimensioning and tolerancing per ANSI Y14.5M-1982.
3. Symbols are defined in the "MO Series Symbol List" in Section 2.2 of Publication No. 95.
4. Dimensions A, A1 and L are measured with the package seated in JEDEC seating plane gauge GS-3.
5. D, D1, and E1 dimensions do not include mold flash or protrusions. Mold flash or protrusions shall not exceed 0.010 inch (0.25mm).
6. E and  $e_A$  are measured with the leads constrained to be perpendicular to datum  $-C-$ .
7.  $e_B$  and  $e_C$  are measured at the lead tips with the leads unconstrained.  $e_C$  must be zero or greater.
8. B1 maximum dimensions do not include dambar protrusions. Dambar protrusions shall not exceed 0.010 inch (0.25mm).
9. N is the maximum number of terminal positions.
10. Corner leads (1, N, N/2 and N/2 + 1) for E8.3, E16.3, E18.3, E28.3, E42.6 will have a B1 dimension of 0.030 - 0.045 inch (0.76 - 1.14mm).

E16.3 (JEDEC MS-001-BB ISSUE D)  
16 LEAD DUAL-IN-LINE PLASTIC PACKAGE

| SYMBOL | INCHES    |       | MILLIMETERS |       | NOTES |
|--------|-----------|-------|-------------|-------|-------|
|        | MIN       | MAX   | MIN         | MAX   |       |
| A      | -         | 0.210 | -           | 5.33  | 4     |
| A1     | 0.015     | -     | 0.39        | -     | 4     |
| A2     | 0.115     | 0.195 | 2.93        | 4.95  | -     |
| B      | 0.014     | 0.022 | 0.356       | 0.558 | -     |
| B1     | 0.045     | 0.070 | 1.15        | 1.77  | 8, 10 |
| C      | 0.008     | 0.014 | 0.204       | 0.355 | -     |
| D      | 0.735     | 0.775 | 18.66       | 19.68 | 5     |
| D1     | 0.005     | -     | 0.13        | -     | 5     |
| E      | 0.300     | 0.325 | 7.62        | 8.25  | 6     |
| E1     | 0.240     | 0.280 | 6.10        | 7.11  | 5     |
| e      | 0.100 BSC |       | 2.54 BSC    |       | -     |
| $e_A$  | 0.300 BSC |       | 7.62 BSC    |       | 6     |
| $e_B$  | -         | 0.430 | -           | 10.92 | 7     |
| L      | 0.115     | 0.150 | 2.93        | 3.81  | 4     |
| N      | 16        |       | 16          |       | 9     |

Rev. 0 12/93

Small Outline Plastic Packages (SOIC)

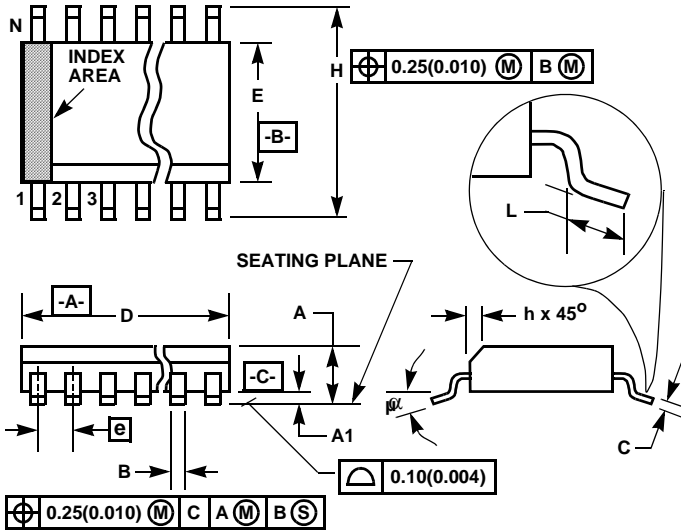

M16.3 (JEDEC MS-013-AA ISSUE C)  
16 LEAD WIDE BODY SMALL OUTLINE PLASTIC PACKAGE

| SYMBOL   | INCHES    |        | MILLIMETERS |       | NOTES |
|----------|-----------|--------|-------------|-------|-------|
|          | MIN       | MAX    | MIN         | MAX   |       |
| A        | 0.0926    | 0.1043 | 2.35        | 2.65  | -     |
| A1       | 0.0040    | 0.0118 | 0.10        | 0.30  | -     |
| B        | 0.013     | 0.0200 | 0.33        | 0.51  | 9     |
| C        | 0.0091    | 0.0125 | 0.23        | 0.32  | -     |
| D        | 0.3977    | 0.4133 | 10.10       | 10.50 | 3     |
| E        | 0.2914    | 0.2992 | 7.40        | 7.60  | 4     |
| e        | 0.050 BSC |        | 1.27 BSC    |       | -     |
| H        | 0.394     | 0.419  | 10.00       | 10.65 | -     |
| h        | 0.010     | 0.029  | 0.25        | 0.75  | 5     |
| L        | 0.016     | 0.050  | 0.40        | 1.27  | 6     |
| N        | 16        |        | 16          |       | 7     |
| $\alpha$ | 0°        | 8°     | 0°          | 8°    | -     |

NOTES:

1. Symbols are defined in the "MO Series Symbol List" in Section 2.2 of Publication Number 95.
2. Dimensioning and tolerancing per ANSI Y14.5M-1982.
3. Dimension "D" does not include mold flash, protrusions or gate burrs. Mold flash, protrusion and gate burrs shall not exceed 0.15mm (0.006 inch) per side.
4. Dimension "E" does not include interlead flash or protrusions. Interlead flash and protrusions shall not exceed 0.25mm (0.010 inch) per side.
5. The chamfer on the body is optional. If it is not present, a visual index feature must be located within the crosshatched area.
6. "L" is the length of terminal for soldering to a substrate.
7. "N" is the number of terminal positions.
8. Terminal numbers are shown for reference only.
9. The lead width "B", as measured 0.36mm (0.014 inch) or greater above the seating plane, shall not exceed a maximum value of 0.61mm (0.024 inch)
10. Controlling dimension: MILLIMETER. Converted inch dimensions are not necessarily exact.

Rev. 0 12/93

Small Outline Plastic Packages (SOIC)

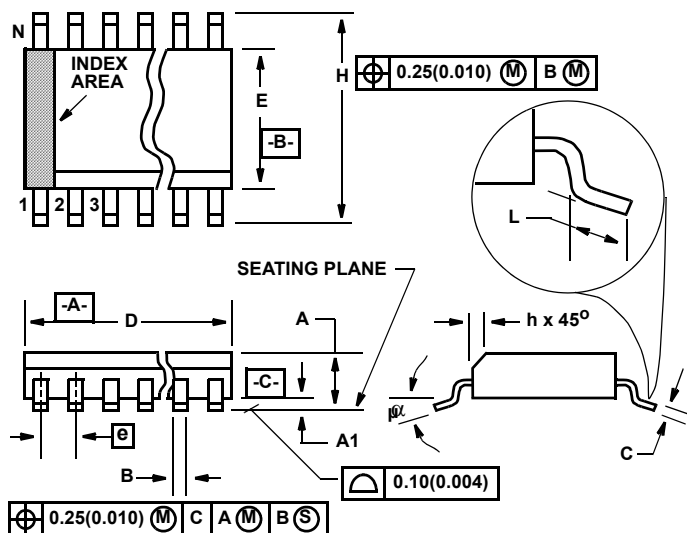

M16.15 (JEDEC MS-012-AC ISSUE C)  
16 LEAD NARROW BODY SMALL OUTLINE PLASTIC PACKAGE

| SYMBOL   | INCHES    |       | MILLIMETERS |       | NOTES |
|----------|-----------|-------|-------------|-------|-------|
|          | MIN       | MAX   | MIN         | MAX   |       |
| A        | 0.053     | 0.069 | 1.35        | 1.75  | -     |
| A1       | 0.004     | 0.010 | 0.10        | 0.25  | -     |
| B        | 0.014     | 0.019 | 0.35        | 0.49  | 9     |
| C        | 0.007     | 0.010 | 0.19        | 0.25  | -     |
| D        | 0.386     | 0.394 | 9.80        | 10.00 | 3     |
| E        | 0.150     | 0.157 | 3.80        | 4.00  | 4     |
| e        | 0.050 BSC |       | 1.27 BSC    |       | -     |
| H        | 0.228     | 0.244 | 5.80        | 6.20  | -     |
| h        | 0.010     | 0.020 | 0.25        | 0.50  | 5     |
| L        | 0.016     | 0.050 | 0.40        | 1.27  | 6     |
| N        | 16        |       | 16          |       | 7     |
| $\alpha$ | 0°        | 8°    | 0°          | 8°    | -     |

Rev. 1 02/02

NOTES:

1. Symbols are defined in the "MO Series Symbol List" in Section 2.2 of Publication Number 95.
2. Dimensioning and tolerancing per ANSI Y14.5M-1982.
3. Dimension "D" does not include mold flash, protrusions or gate burrs. Mold flash, protrusion and gate burrs shall not exceed 0.15mm (0.006 inch) per side.
4. Dimension "E" does not include interlead flash or protrusions. Interlead flash and protrusions shall not exceed 0.25mm (0.010 inch) per side.
5. The chamfer on the body is optional. If it is not present, a visual index feature must be located within the crosshatched area.
6. "L" is the length of terminal for soldering to a substrate.
7. "N" is the number of terminal positions.
8. Terminal numbers are shown for reference only.
9. The lead width "B", as measured 0.36mm (0.014 inch) or greater above the seating plane, shall not exceed a maximum value of 0.61mm (0.024 inch)
10. Controlling dimension: MILLIMETER. Converted inch dimensions are not necessarily exact.

All Intersil products are manufactured, assembled and tested utilizing ISO9000 quality systems. Intersil Corporation's quality certifications can be viewed at website [www.intersil.com/design/quality](http://www.intersil.com/design/quality)

*Intersil products are sold by description only. Intersil Corporation reserves the right to make changes in circuit design and/or specifications at any time without notice. Accordingly, the reader is cautioned to verify that data sheets are current before placing orders. Information furnished by Intersil is believed to be accurate and reliable. However, no responsibility is assumed by Intersil or its subsidiaries for its use; nor for any infringements of patents or other rights of third parties which may result from its use. No license is granted by implication or otherwise under any patent or patent rights of Intersil or its subsidiaries.*

For information regarding Intersil Corporation and its products, see web site [www.intersil.com](http://www.intersil.com)