

The SP8401 is a very low phase noise variable modulus divider. Special circuit techniques have been used to reduce the phase noise considerably below that produced by standard dividers. The modulus control input is CMOS or TTL compatible.

The SP8401 is packaged in a 28 pin plastic SO package to be compatible with the SP8400 and SP8402 devices.

### FEATURES

- Very low Phase Noise (Typically -160dBc/Hz at 1kHz offset)
- Supply Voltage 5V

### ABSOLUTE MAXIMUM RATINGS

Supply Voltage	6.5V
Output Current	20mA
Storage Temperature Range	-55°C to +125°C
Maximum Clock Input Voltage	2.5V p-p

DS3230

ISSUE 3.1

December 2007

**Ordering Information**  
SP8401 KG MPES(Commercial Grade)

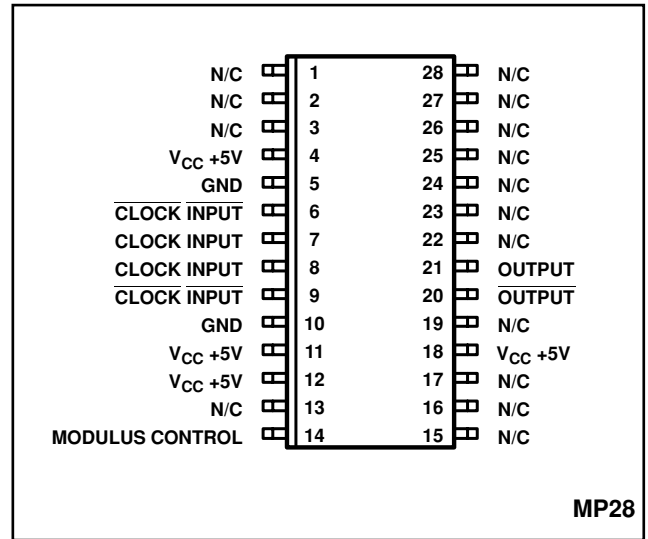

Fig.1 Pin connections - top view

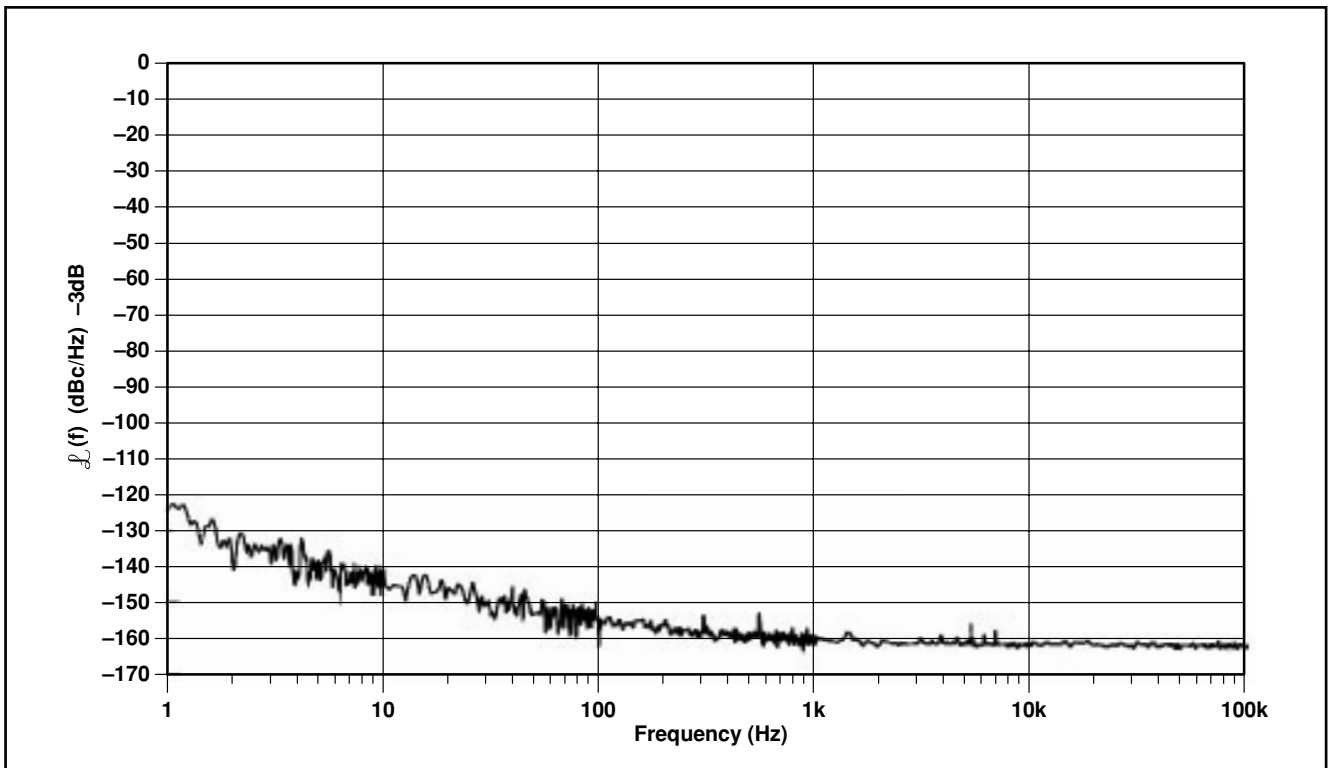

Fig.2 Typical single sideband phase noise measured at 300MHz

# SP8401

## ELECTRICAL CHARACTERISTICS

Guaranteed over: Supply voltage  $V_{CC} = +4.75V$  to  $+5.25V$  Temperature  $T_{amb} = -20^{\circ}C$  to  $+85^{\circ}C$   
 Tested at  $+4.75V$  and  $+5.25V$  at  $T_{amb} = +25^{\circ}C$

Characteristic	Pin	Value			Units	Conditions
		Min.	Typ.	Max.		
Supply current	4, 11, 12, 18	50	57	64	mA	Output loaded with 300R See Fig.5 p-p @ 330MHz input ÷ 11 mode Output loaded with 300R RMS Sine wave into 50 Ohms (dBm equivalent) See Fig.3
Output voltage swing	20, 21	340	440		mV	
Input sensitivity 50MHz to 300MHz	7, 8			140 (-4)	mV dBm	
<b>Modulus Control Inputs</b>						
Logic high voltage	14	2.2			V	÷ 10 mode
Low low voltage	14			0.8		÷ 11 mode
Input current	14			180	$\mu A$	Modulus control input voltage 5V
Set up time $t_s$	14		4		ns	
Release time $t_r$	14		4		ns	

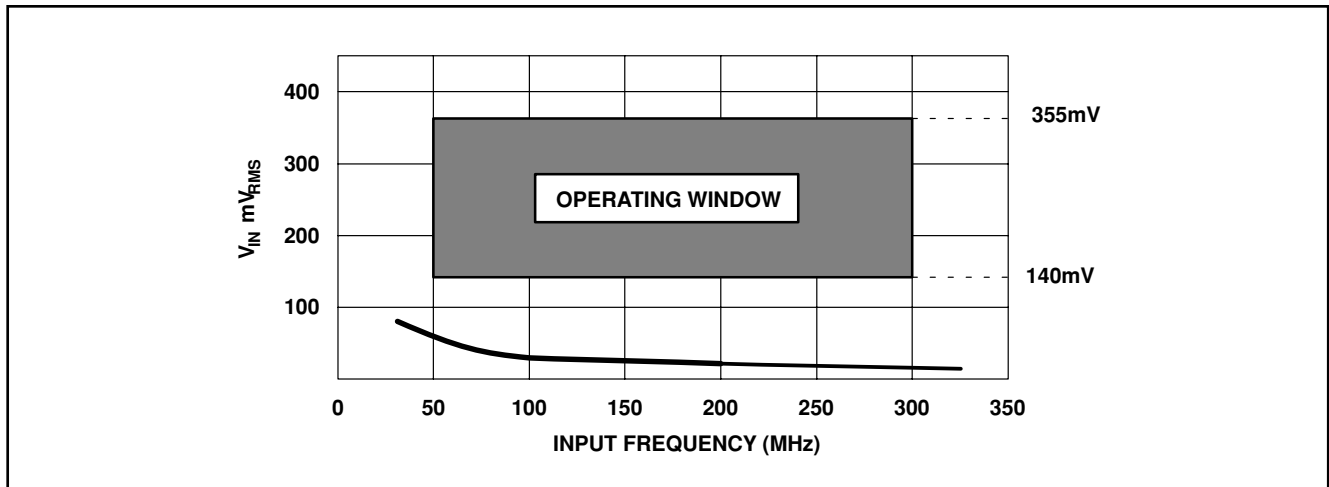

Fig.3 Typical input sensitivity

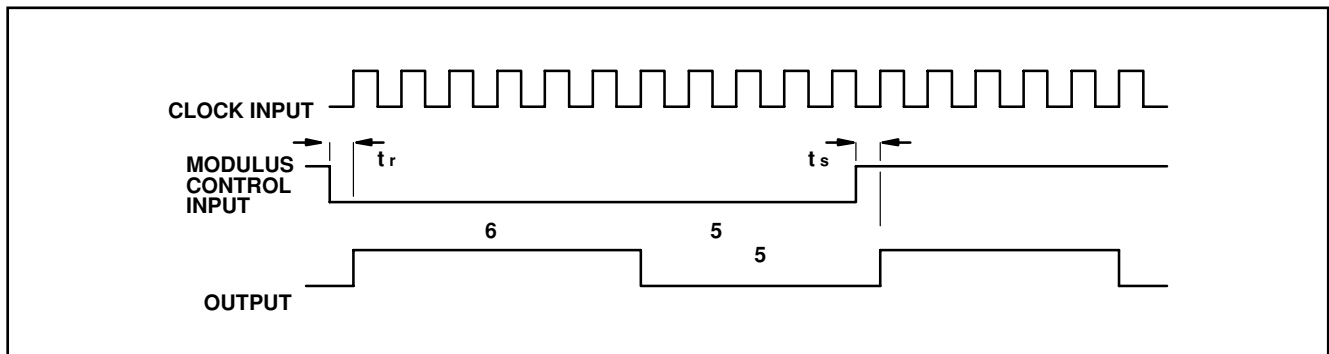

Fig.4 Timing diagram

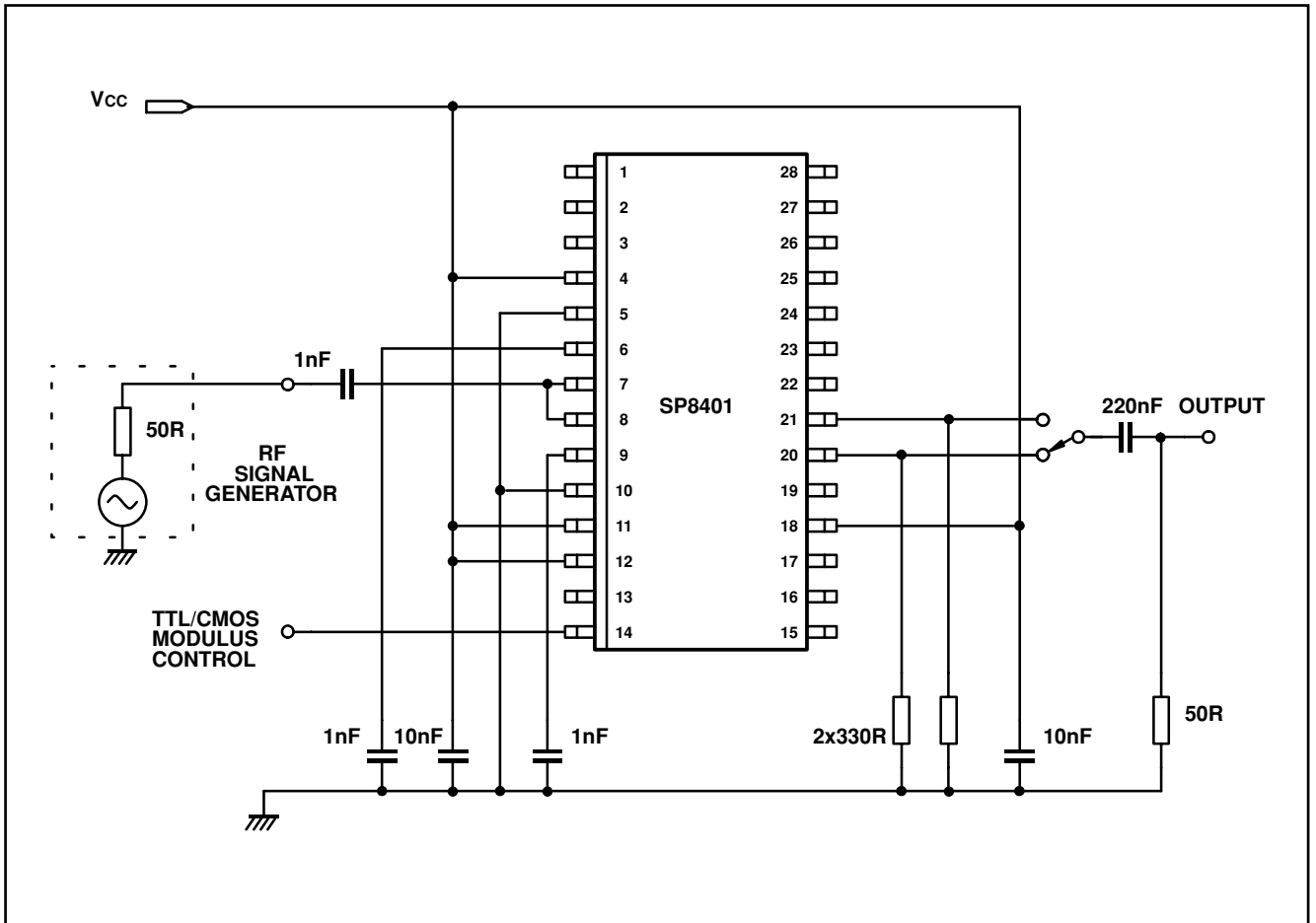

Fig.4 Test circuit



**For more information about all Zarlink products  
visit our Web Site at  
[www.zarlink.com](http://www.zarlink.com)**

Information relating to products and services furnished herein by Zarlink Semiconductor Inc. or its subsidiaries (collectively "Zarlink") is believed to be reliable. However, Zarlink assumes no liability for errors that may appear in this publication, or for liability otherwise arising from the application or use of any such information, product or service or for any infringement of patents or other intellectual property rights owned by third parties which may result from such application or use. Neither the supply of such information or purchase of product or service conveys any license, either express or implied, under patents or other intellectual property rights owned by Zarlink or licensed from third parties by Zarlink, whatsoever. Purchasers of products are also hereby notified that the use of product in certain ways or in combination with Zarlink, or non-Zarlink furnished goods or services may infringe patents or other intellectual property rights owned by Zarlink.

This publication is issued to provide information only and (unless agreed by Zarlink in writing) may not be used, applied or reproduced for any purpose nor form part of any order or contract nor to be regarded as a representation relating to the products or services concerned. The products, their specifications, services and other information appearing in this publication are subject to change by Zarlink without notice. No warranty or guarantee express or implied is made regarding the capability, performance or suitability of any product or service. Information concerning possible methods of use is provided as a guide only and does not constitute any guarantee that such methods of use will be satisfactory in a specific piece of equipment. It is the user's responsibility to fully determine the performance and suitability of any equipment using such information and to ensure that any publication or data used is up to date and has not been superseded. Manufacturing does not necessarily include testing of all functions or parameters. These products are not suitable for use in any medical products whose failure to perform may result in significant injury or death to the user. All products and materials are sold and services provided subject to Zarlink's conditions of sale which are available on request.

Purchase of Zarlink's I<sup>2</sup>C components conveys a licence under the Philips I<sup>2</sup>C Patent rights to use these components in and I<sup>2</sup>C System, provided that the system conforms to the I<sup>2</sup>C Standard Specification as defined by Philips.

Zarlink, ZL and the Zarlink Semiconductor logo are trademarks of Zarlink Semiconductor Inc.

Copyright Zarlink Semiconductor Inc. All Rights Reserved.

**TECHNICAL DOCUMENTATION - NOT FOR RESALE**

---