

## 80C592

### *8-Bit Microcontroller with On-Chip CAN*

The P8xC592 is a single-chip 8-bit high-performance microcontroller with on-chip CAN-controller, derived from the 80C51 microcontroller family.

---

#### **Rochester Electronics Manufactured Components**

Rochester branded components are manufactured using either die/wafers purchased from the original suppliers or Rochester wafers recreated from the original IP. All re-creations are done with the approval of the Original Component Manufacturer (OCM).

Parts are tested using original factory test programs or Rochester developed test solutions to guarantee product meets or exceeds the OCM data sheet.

#### **Quality Overview**

- ISO-9001
- AS9120 certification
- Qualified Manufacturers List (QML) MIL-PRF-35835
  - Class Q Military
  - Class V Space Level
- Qualified Suppliers List of Distributors (QSLD)
  - Rochester is a critical supplier to DLA and meets all industry and DLA standards.

Rochester Electronics, LLC is committed to supplying products that satisfy customer expectations for quality and are equal to those originally supplied by industry manufacturers.

---

*The original manufacturer's datasheet accompanying this document reflects the performance and specifications of the Rochester manufactured version of this device. Rochester Electronics guarantees the performance of its semiconductor products to the original OCM specifications. 'Typical' values are for reference purposes only. Certain minimum or maximum ratings may be based on product characterization, design, simulation, or sample testing.*

**FOR REFERENCE ONLY**

# DATA SHEET

## **P8xC592** 8-bit microcontroller with on-chip CAN

Product specification  
Supersedes data of January 1995  
File under Integrated Circuits, IC18

1996 Jun 27



**8-bit microcontroller with on-chip CAN****P8xC592**

<b>CONTENTS</b>	14	<b>INTERRUPT SYSTEM</b>
1	14.1	Interrupt Enable and Priority Registers
2	14.2	Interrupt Vectors
3	14.3	Interrupt Priority
4	15	<b>POWER REDUCTION MODES</b>
5	15.1	Power Control Register (PCON)
6	15.2	CAN Sleep Mode
7	15.3	Idle Mode
7.1	15.4	Power-down Mode
7.2	16	<b>OSCILLATOR CIRCUITRY</b>
7.3	17	<b>RESET CIRCUITRY</b>
8	17.1	Power-on Reset
9	18	<b>INSTRUCTION SET</b>
9.1	18.1	Addressing Modes
9.2	18.2	Instruction Set
9.3	19	<b>ABSOLUTE MAXIMUM RATINGS (note 1)</b>
10	20	<b>DC CHARACTERISTICS</b>
10.1	21	<b>AC CHARACTERISTICS</b>
11	22	<b>CAN APPLICATION INFORMATION</b>
11.1	22.1	Latency time requirements
11.2	22.2	Connecting a P8xC592 to a bus line (physical layer)
11.3	23	<b>PACKAGE OUTLINES</b>
12	24	<b>SOLDERING</b>
13	24.1	Introduction
13.1	24.2	Reflow soldering
13.2	24.3	Wave soldering
13.3	24.4	Repairing soldered joints
13.4	25	<b>DEFINITIONS</b>
13.5	26	<b>LIFE SUPPORT APPLICATIONS</b>
13.6		

## 8-bit microcontroller with on-chip CAN

## P8xC592

**1 FEATURES**

- 80C51 central processing unit (CPU)
- 16 kbytes on-chip ROM, externally expandible to 64 kbytes
- 2 × 256 bytes on-chip RAM, externally expandible to 64 kbytes
- Two standard 16-bit timers/counters
- One additional 16-bit timer/counter coupled to four capture and three compare registers
- 10-bit ADC with 8 multiplexed analog inputs
- Two 8-bit resolution Pulse Width Modulated outputs
- 15 interrupt sources with 2 priority levels (2 to 6 external interrupt sources possible)
- Five 8-bit I/O ports, plus one 8-bit input port shared with analog inputs
- CAN-controller (CAN = Controller Area Network) with DMA data transfer facility to internal RAM
- 1 Mbit/s CAN-controller with bus failure management facility
- $\frac{1}{2}AV_{DD}$  reference voltage
- Full-duplex UART compatible with the standard 80C51
- On-chip Watchdog Timer (WDT)
- 1.2 to 16 MHz clock frequency.

**2 GENERAL DESCRIPTION**

The P8xC592 is a single-chip 8-bit high-performance microcontroller with on-chip CAN-controller, derived from the 80C51 microcontroller family.

It uses the powerful 80C51 instruction set.

Figure 1 shows a block diagram of the P8xC592.

The P8xC592 is manufactured in an advanced CMOS process, and is designed for use in automotive and general industrial applications. In addition to the 80C51 standard features, the device provides a number of dedicated hardware functions for these applications.

Two versions of the P8xC592 will be offered:

- P80C592 (without ROM)
- P83C592 (with ROM).

Hereafter these versions will be referred to as P8xC592.

The temperature range includes (max.  $f_{CLK} = 16$  MHz):

- -40 to +85 °C version, for general applications
- -40 to +125 °C version for automotive applications.

The P8xC592 combines the functions of the P8xC552 (microcontroller) and the PCA82C200 (Philips CAN-controller) with the following enhanced features:

- 16 kbytes Program Memory
- 2 × 256 bytes Data Memory
- DMA between CAN Transmit/Receive Buffer and internal RAM.

The main differences between P8xC592 and P8xC552 are:

- 16 kbytes programmable ROM (P8xC552 has 8 kbytes)
- Additional 256 bytes RAM
- A CAN-controller instead of the I<sup>2</sup>C-serial interface.

**3 ORDERING INFORMATION**

TYPE NUMBER	PACKAGE			TEMPERATURE RANGE (°C)	FREQ. (MHz)
	NAME	DESCRIPTION	VERSION		
<b>Without ROM</b>					
P80C592FFA	PLCC68	plastic leaded chip carrier; 68 leads	SOT188-2	-40 to +85	1.2 to 16
P80C592FHA				-40 to +125	
<b>With ROM</b>					
P83C592FFA	PLCC68	plastic leaded chip carrier; 68 leads	SOT188-2	-40 to +85	1.2 to 16
P83C592FHA				-40 to +125	

# 8-bit microcontroller with on-chip CAN

# P8xC592

## 4 BLOCK DIAGRAM

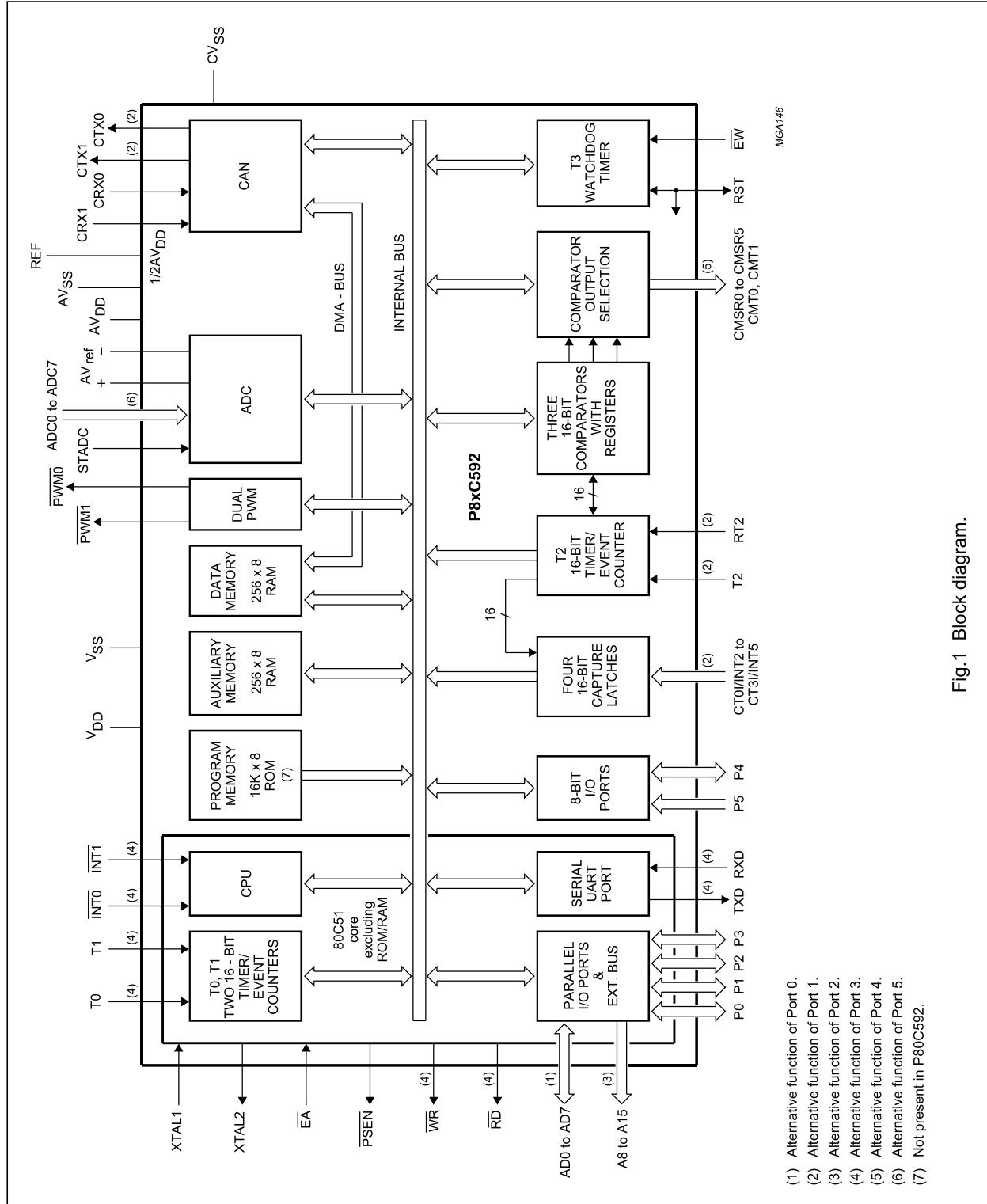

- (1) Alternative function of Port 0.
- (2) Alternative function of Port 1.
- (3) Alternative function of Port 2.
- (4) Alternative function of Port 3.
- (5) Alternative function of Port 4.
- (6) Alternative function of Port 5.
- (7) Not present in P80C592.

8-bit microcontroller with on-chip CAN

P8xC592

5 PINNING

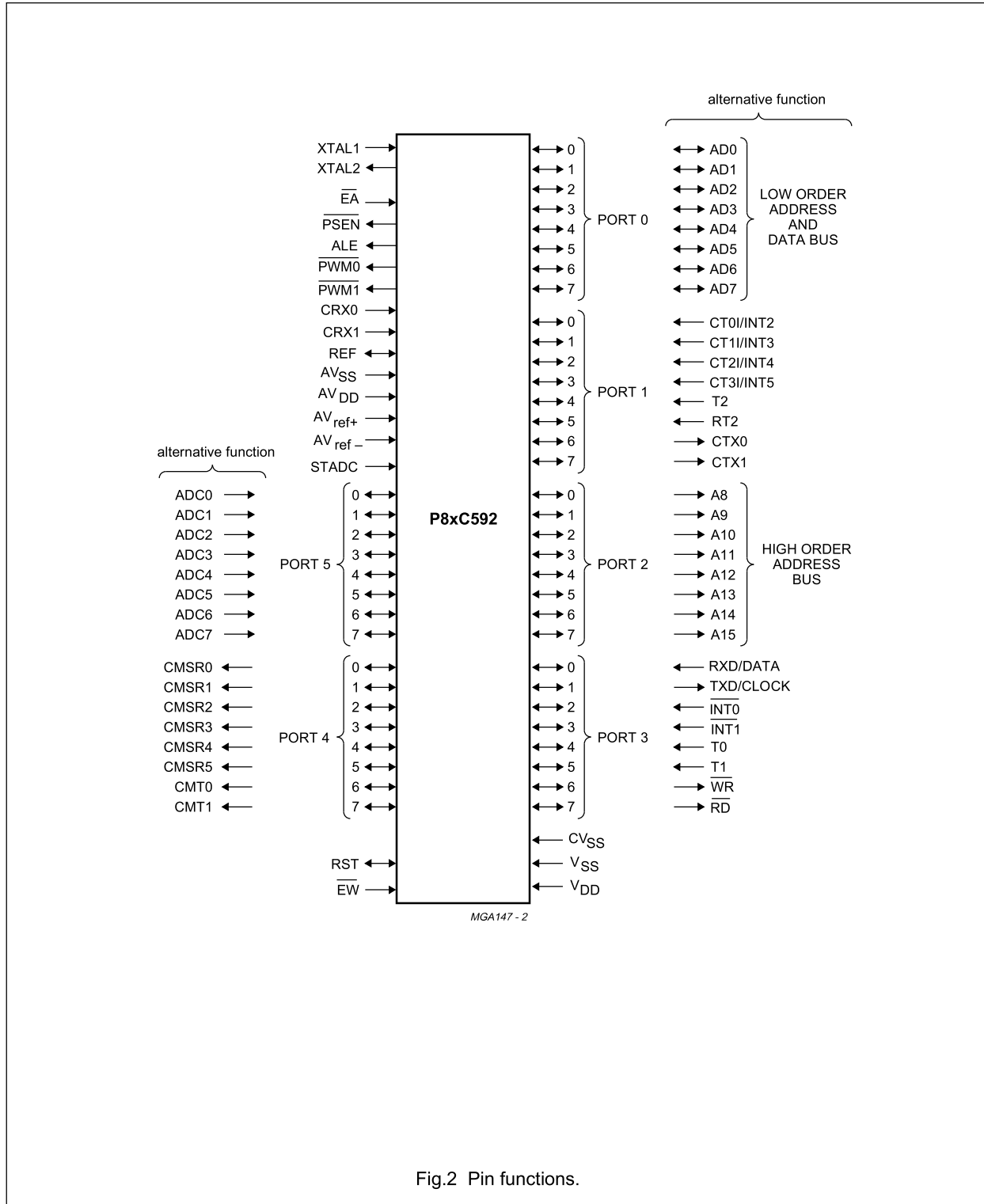

Fig.2 Pin functions.

8-bit microcontroller with on-chip CAN

P8xC592

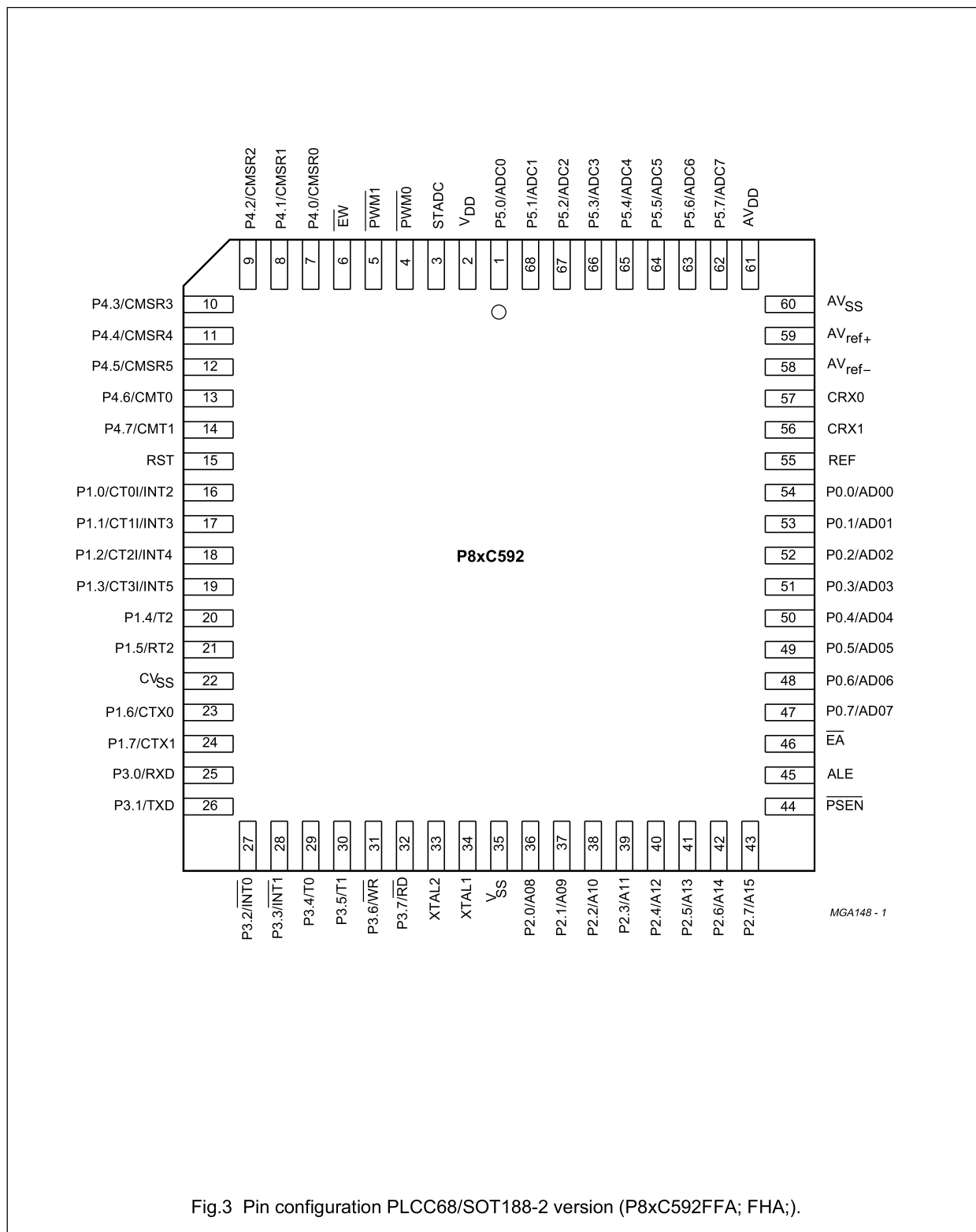

Fig.3 Pin configuration PLCC68/SOT188-2 version (P8xC592FFA; FHA;).

## 8-bit microcontroller with on-chip CAN

## P8xC592

**Table 1** Pin description for **single function** pins (SOT188-2; see note 1)

SYMBOL	PIN	DESCRIPTION
V <sub>DD</sub>	2	<b>Power supply</b> , digital part (+5 V). For normal operation and power reduced modes.
STADC	3	<b>Start ADC operation</b> . Input starting analog-to-digital conversion (note 2). This pin must not float.
PWM0	4	<b>Pulse width modulation output 0</b> .
PMW1	5	<b>Pulse width modulation output 1</b> .
EW	6	<b>Enable Watchdog Timer (WDT)</b> : enable for T3 Watchdog Timer and disable Power-down mode. This pin must not float.
RST	15	<b>Reset</b> : input to reset the P8xC592 (note 3).
CV <sub>SS</sub>	22	<b>CAN ground potential</b> for the CAN transmitter outputs.
XTAL2	33	<b>Crystal pin 2</b> : output of the inverting amplifier that forms the oscillator. When an external clock oscillator is used this pin is left open-circuit.
XTAL1	34	<b>Crystal pin 1</b> : input to the inverting amplifier that forms the oscillator, and input to the internal clock generator. Receives the external clock oscillator signal, when an external oscillator is used.
V <sub>SS</sub>	35	<b>Ground</b> , digital part.
PSEN	44	<b>Program Store Enable</b> : Read strobe to external Program Memory (active LOW). Drive: 8 × LSTTL inputs.
ALE	45	<b>Address Latch Enable</b> : latches the Low-byte of the address during accesses to external memory (note 4). Drive: 8 × LSTTL inputs; handles CMOS inputs without an external pull-up.
EA	46	<b>External Access input</b> . See note 5.
REF	55	$\frac{1}{2}AV_{DD}$ <b>reference voltage</b> output respectively input (note 6).
CRX1	56	<b>Inputs from the CAN-bus line</b> to the differential input comparator of the on-chip CAN-controller (note 7).
CRX0	57	
AV <sub>REF-</sub>	58	<b>Low-end of ADC</b> (analog-to-digital) conversion reference resistor.
AV <sub>REF+</sub>	59	<b>High-end of ADC</b> (analog-to-digital) conversion reference resistor (note 8).
AV <sub>SS</sub>	60	<b>Ground</b> , analog part. For ADC, CAN receiver and reference voltage.
AV <sub>DD</sub>	61	<b>Power supply</b> , analog part (+5 V). For ADC, CAN receiver and reference voltage.

**Notes**

1. To avoid a 'latch up' effect at power-on:  $V_{SS} - 0.5 V < \text{'voltage on any pin at any time'} < V_{DD} + 0.5 V$ .
2. Triggered by a rising edge. ADC operation can also be started by software.
3. RST also provides a reset pulse as output when timer T3 overflows or after a CAN wake-up from Power-down.
4. ALE is activated every six oscillator periods. During an external data memory access one ALE pulse is skipped.
5. See Section 7.1, Table 3 for EA operation. For P83Cxxx microcontrollers specified with the option 'ROM-code protection', the EA pin is latched during reset and is 'don't care' after reset, regardless of whether the ROM-code protection is selected or not.

## 8-bit microcontroller with on-chip CAN

P8xC592

6. Pin 55, REF:
- Selection of input resp. output dependent of CAN Control Register bit 5 (CR.5; see Section 13.5.3 Table 32).
  - If the internal reference is used, then REF should be connected to  $AV_{SS}$  via a capacitor with a value of  $\geq 10$  nF.
  - After an external reset (RST = HIGH) the internal  $\frac{1}{2}AV_{DD}$  source is activated and, REF is a reference output.
  - If the CAN-controller is in the reset state, e.g. after an external reset, then the  $\frac{1}{2}AV_{DD}$  source is switched off during Power-down mode.
7. CAN-bus line:
- CRX0 level > CRX1 level is interpreted as a logic 1 (recessive).
  - CRX0 level < CRX1 level is interpreted as a logic 0 (dominant).
8. The level of  $AV_{REF+}$  must be higher than that of  $AV_{REF-}$ .

**Table 2** Pin description for pins with **alternative functions** (SOT188-2 and NO330; see note 1)

SYMBOL		PIN	DESCRIPTION
DEFAULT	ALTERNATIVE		
<b>Port 4</b>			
P4.0 to P4.7		7 to 14	<b>8-bit quasi-bidirectional I/O port.</b>
	CMSR0	7	<b>Compare and Set/Reset outputs</b> for Timer T2.
	CMSR1	8	
	CMSR2	9	
	CMSR3	10	
	CMSR4	11	
	CMSR5	12	
	CMT0	13	<b>Compare and toggle outputs</b> for Timer T2.
	CMT1	14	
<b>Port 1</b>			
P1.0 to P1.7		16 to 21, 23, 24	<b>8-bit quasi-bidirectional I/O port.</b>
	CT0/INT2	16	<b>Capture timer inputs</b> for Timer T2, or <b>External interrupt inputs.</b>
	CT1/INT3	17	
	CT2/INT4	18	
	CT3/INT5	19	
	T2	20	<b>T2 event input</b> (rising edge triggered).
	RT2	21	<b>T2 timer reset input</b> (rising edge triggered).
	CTX0	23	<b>CAN transmitter output 0</b> (note 2).
	CTX1	24	<b>CAN transmitter output 1</b> (note 2).

## 8-bit microcontroller with on-chip CAN

P8xC592

SYMBOL		PIN	DESCRIPTION
DEFAULT	ALTERNATIVE		
<b>Port 3</b>			
P3.0 to P3.7		25 to 32	8-bit quasi-bidirectional I/O port.
	RXD	25	Serial Input Port.
	TXD	26	Serial Output Port.
	$\overline{\text{INT0}}$	27	External interrupt inputs.
	$\overline{\text{INT1}}$	28	
	T0	29	Timer 0 external input.
	T1	30	Timer 1 external input.
	$\overline{\text{WR}}$	31	External Data Memory Write strobe.
	$\overline{\text{RD}}$	32	External Data Memory Read strobe.
<b>Port 2 (Sink/source: 1 × TTL = 4 × LSTTL inputs)</b>			
P2.0 to P2.7		36 to 43	8-bit quasi-bidirectional I/O port.
	A08 to A15		High-order address byte for external memory.
<b>Port 0 (Sink/source: 8 × LSTTL inputs)</b>			
P0.7 to P0.0		47 to 54	8-bit open drain bidirectional I/O port.
	AD7 to AD0		Multiplexed Low-order address and Data bus for external memory.
<b>Port 5</b>			
P5.7 to P5.0		62 to 68, 1	8-bit input port.
	ADC7 to ADC0		8 input channels to ADC.

**Notes**

1. To avoid a 'latch up' effect at power-on:  $V_{SS} - 0.5 \text{ V} < \text{'voltage on any pin at any time'} < V_{DD} + 0.5 \text{ V}$ .
2. If the CAN-controller is in the reset state (e.g. after a power-up reset; CAN Control Register bit CR.0; see Section 13.5.3 Table 32), the CAN transmitter outputs are floating and the pins P1.6 and P1.7 can be used as open-drain port pins. After a power-up reset the port data is HIGH, leaving the pins P1.6 and P1.7 floating.



## 8-bit microcontroller with on-chip CAN

## P8xC592

**6 FUNCTIONAL DESCRIPTION**

The P8xC592 functions will be described as shown in the following overview:

- Memory organization
- I/O Port structure
- Pulse Width Modulated outputs
- Analog-to-digital Converter
- Timers/Counters
- Serial I/O Ports
- Interrupt system
- Power reduction modes
- Oscillator circuitry
- Reset circuitry
- Instruction Set.

**7 MEMORY ORGANIZATION**

The Central Processing Unit (CPU) manipulates operands in three memory spaces (see Fig.4) as follows:

- 16 kbytes internal resp. 64 kbytes external Program Memory
- 512 bytes internal Data Memory MAIN- and AUXILIARY RAM
- up to 64 kbytes external Data Memory (with 256 bytes residing in the internal AUXILIARY RAM).

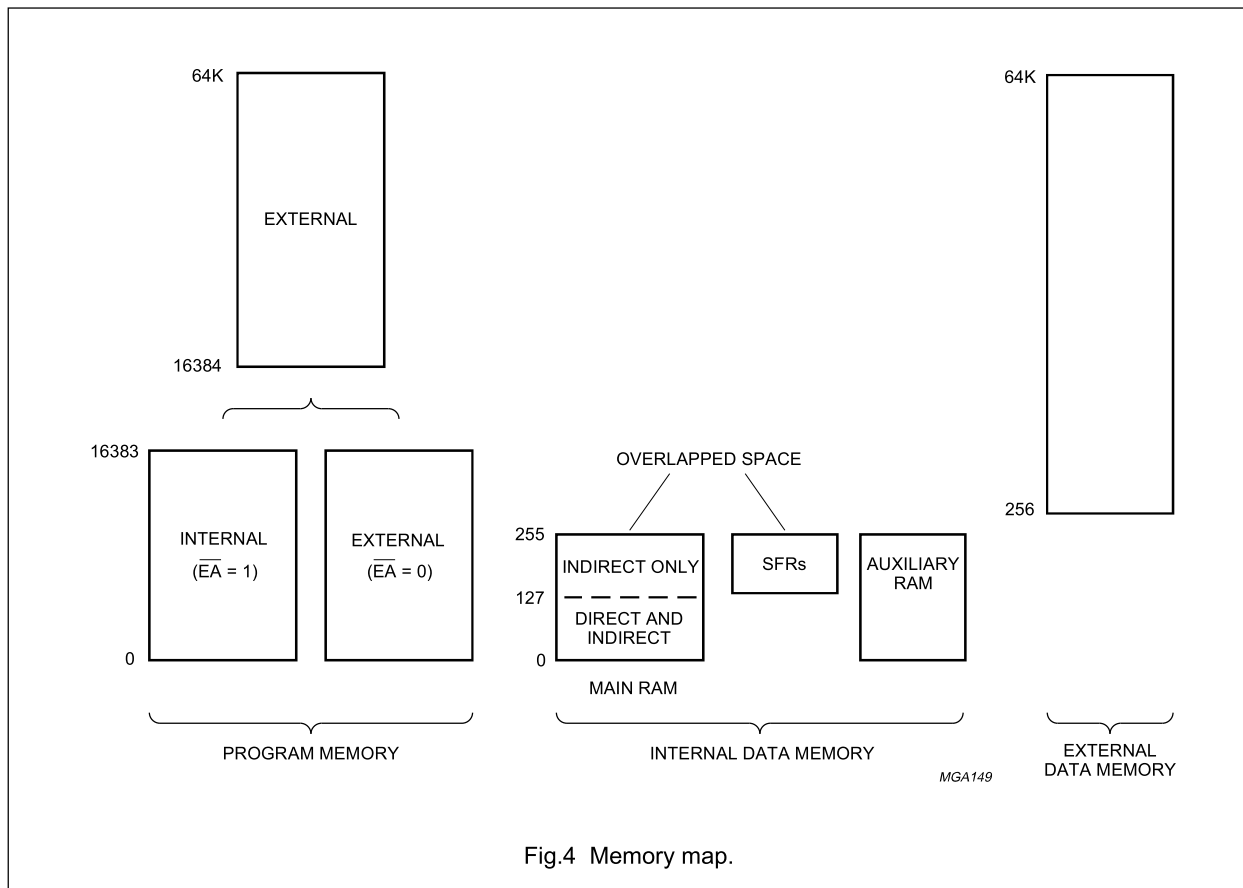

Fig.4 Memory map.

## 8-bit microcontroller with on-chip CAN

## P8xC592

## 7.1 Program Memory

The Program Memory of the P8xC592 consists of 16 kbytes ROM on-chip, externally expandible up to 64 kbytes.

**Table 3** Instruction fetch controlled by  $\overline{EA}$

PIN $\overline{EA}$ (note 1)		INSTRUCTIONS FETCHED FROM:	ADDRESS LOCATION
DURING RESET LATCHED TO:	AFTER RESET		
H	–	internal Program Memory (note 2)	0000H → 3FFFH
H	–	external Program Memory	4000H → FFFFH
L	–		0000H → FFFFH
–	'don't care'	–	–

## Notes

1. This implementation prevents reading of the internal program code by switching from external Program Memory during a MOVC instruction.
2. By setting a security bit the internal Program Memory content is protected, which means it cannot be read out. If the security bit has been set to LOW there are no restrictions for the MOVC instruction.

## 7.2 Internal Data Memory

The internal Data Memory is physically built-up and accessible as shown in Table 4 (see Fig.5).

**Table 4** Internal Data Memory size and address mode

INTERNAL DATA MEMORY	SIZE	LOCATION	ADDRESS MODE		POINTERS
			DIRECT	INDIRECT	
MAIN RAM (note 1)	256 bytes	0 to 127	X	X	address pointers are R0 and R1 of the selected register bank
		128 to 255	–	X	
AUXILIARY RAM (note 2)	256 bytes	0 to 255	–	X	address pointers are R0 and R1 of the selected register bank and the DPTR
SFRs (note 3)	128 bytes	128 to 255	X	–	–

## Notes

1. MAIN RAM can be addressed directly and indirectly as in the 80C51.
2. AUXILIARY RAM (0 to 255):
  - a) Is indirectly addressable in the same way as the external Data Memory with MOVX instructions.
  - b) Access will not affect the ports P0, P2, P3.6 and P3.7 during internal program execution.
3. SFRs = Special Function Registers.

## 8-bit microcontroller with on-chip CAN

P8xC592

## 7.2.1 MAIN RAM

Four 8-bit register banks occupy the lower RAM area,

- BANK 0: location 0 to 7
- BANK 1: location 8 to 15
- BANK 2: location 16 to 23
- BANK 4: location 24 to 31.

Only one of these banks may be enabled at the same time.

The next 16 bytes, locations 32 through 45, contains 128 directly addressable bit locations.

The stack can be located anywhere in the internal MAIN RAM address space. The stack depth is only limited by the internal RAM space available. All registers except the program counter and the four 8-bit register banks reside in the SFR address space.

## 7.3 External Data Memory

An access to external Data Memory locations higher than 255 will be performed with the MOVX @DPTR instructions in the same way as in the 80C51 structure, i.e. with P0 and P2 as data/address bus and P3.6 and P3.7 as Write and Read strobe signals.

Note that these external Data Memory locations cannot be accessed with R0 or R1 as address pointer.

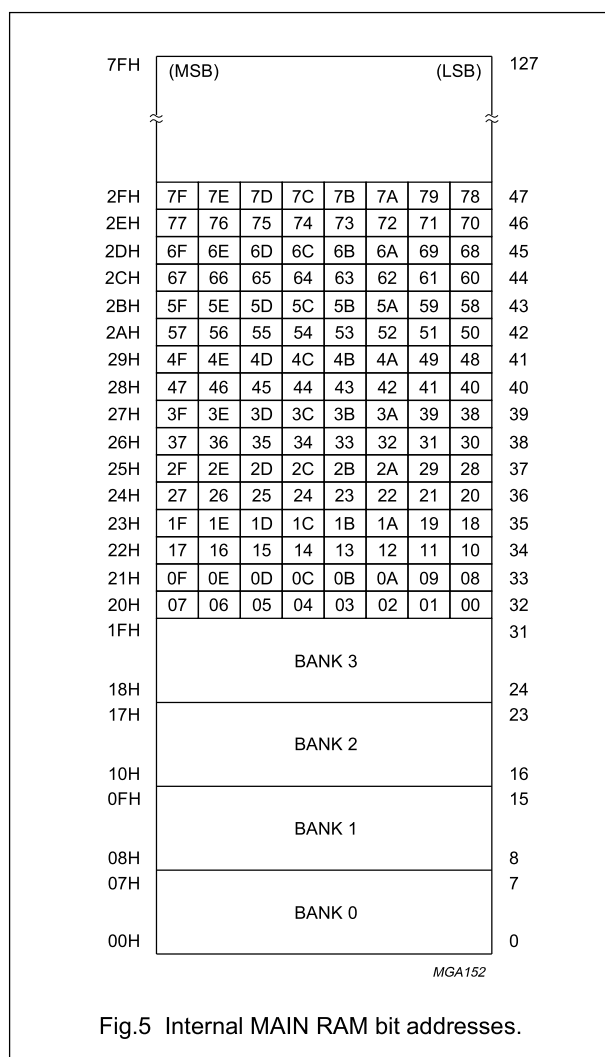

Fig.5 Internal MAIN RAM bit addresses.

8-bit microcontroller with on-chip CAN

P8xC592

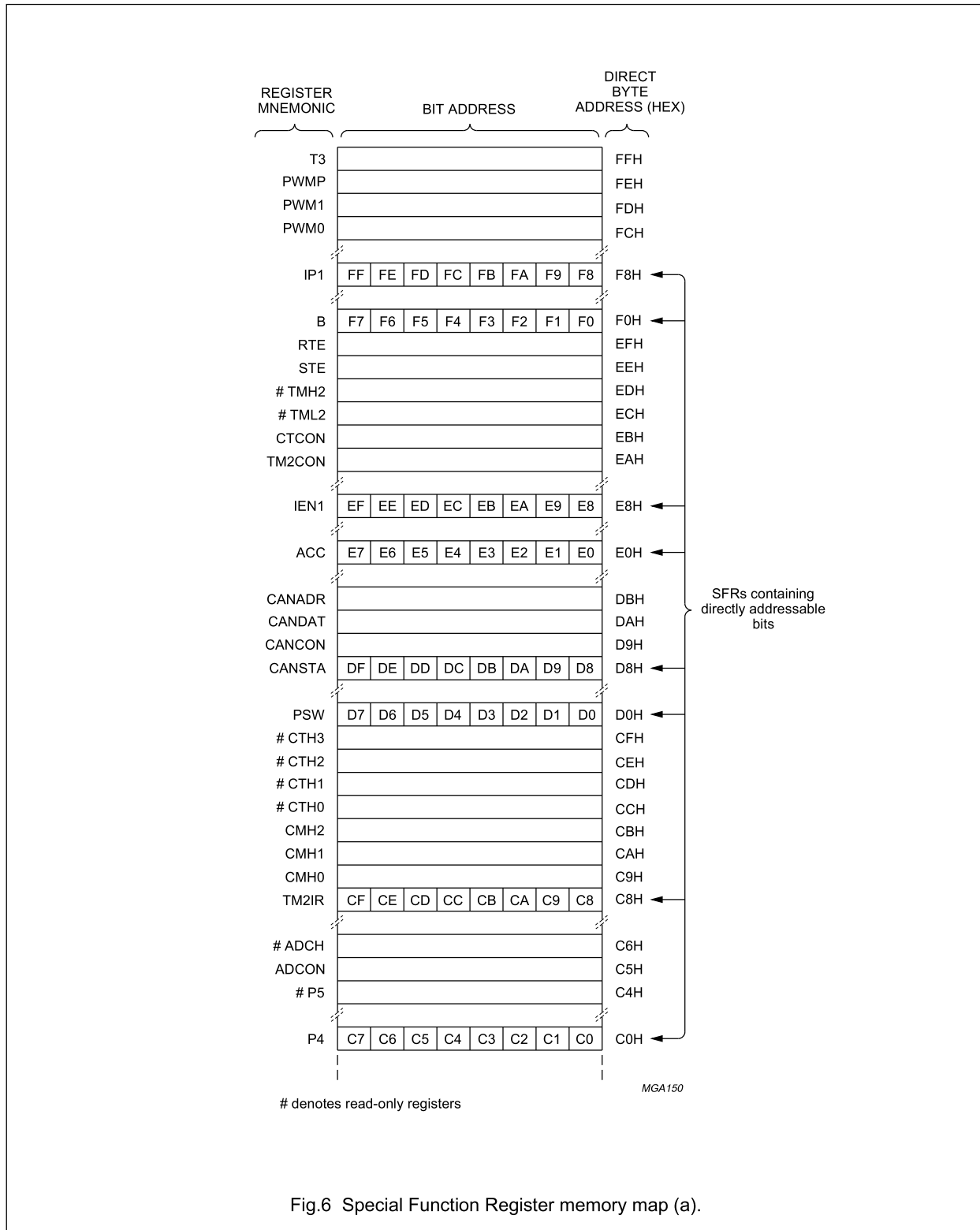

Fig.6 Special Function Register memory map (a).

8-bit microcontroller with on-chip CAN

P8xC592

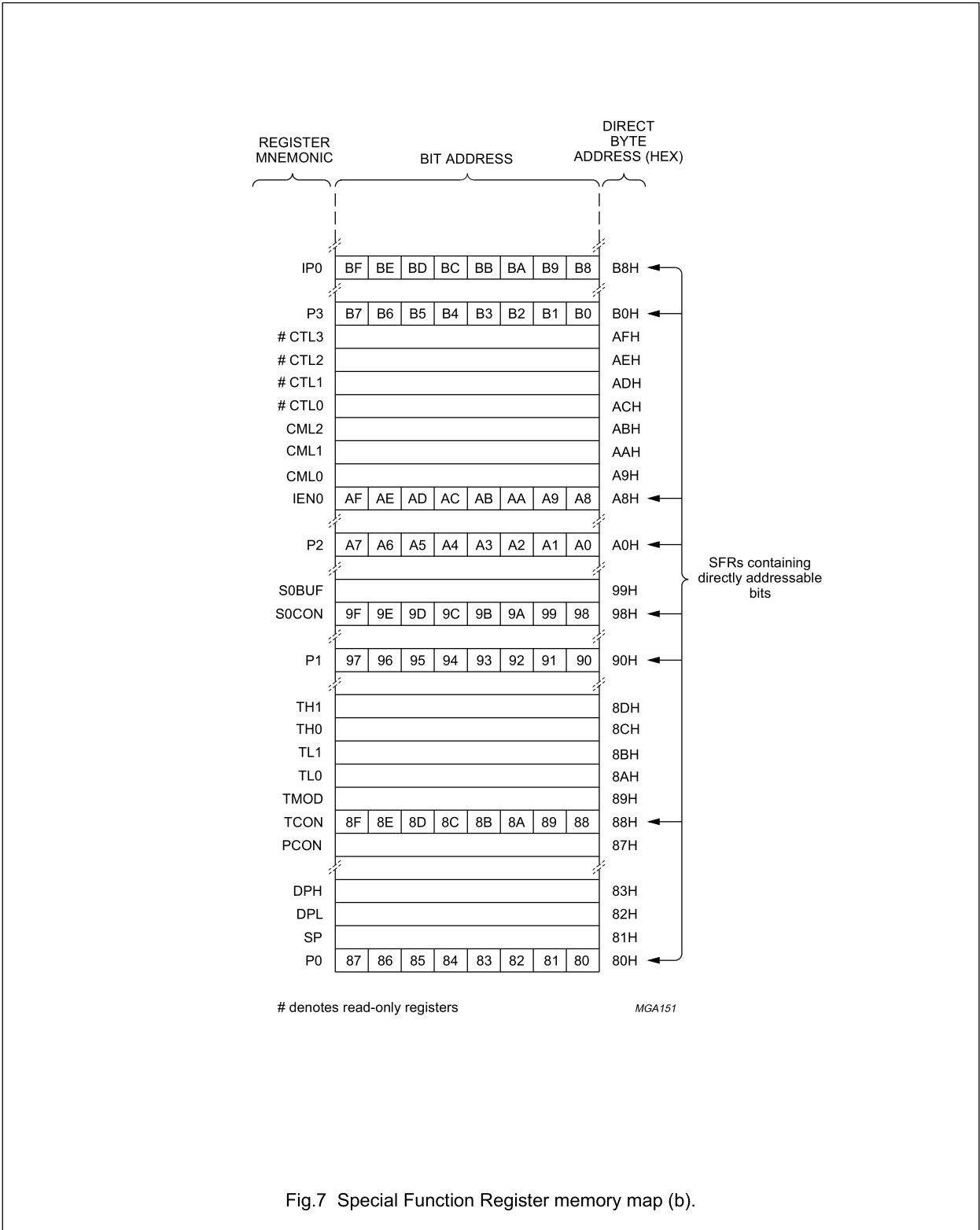

Fig.7 Special Function Register memory map (b).

## 8-bit microcontroller with on-chip CAN

## P8xC592

**8 I/O PORT STRUCTURE**

The P8xC592 has six 8-bit parallel ports: Port 0 to Port 5. In addition to the standard 8-bit parallel ports, the I/O facilities also include a number of special I/O lines. The use of a Port 1, Port 3 or Port 4 pins as an alternative function is carried out automatically provided the associated SFR bit is set HIGH.

**Table 5 Default Port functions**

PORT	TYPE	FUNCTION	REMARKS
Port 0	I/O	The same as in the 80C51	Except for the additional functions of P1.6 and P1.7.
Port 1	I/O		
Port 2	I/O		
Port 3	I/O		
Port 4	I/O	Parallel I/O port	Parallel I/O function is identical to Port1, 2 and 3.
Port 5	I	Parallel input port with an input function only	May be used as normal inputs if the ADC function is inoperative.

**Table 6 Alternative Port functions**

PORT	TYPE	FUNCTION	REMARKS
Port 0	I/O	Multiplexed Low-order address and Data bus for external memory (AD7 to AD0)	Provides the multiplexed Low-order address and data bus used for expanding the P8xC592 with standard memories and peripherals.
Port 1	I/O	Capture timer inputs for Timer T2 (CT0I to CT3I), or External interrupt request inputs (INT2 to INT5)	External interrupt request inputs, if capture information is not utilized.
		T2 event input (T2)	External counter input.
		T2 timer reset input (RT2)	External counter reset input.
		CAN transmitter output 0 (CTX0)	CTX0 and CTX1 outputs of the CAN interface (note 1).
		CAN transmitter output 1 (CTX1)	
Port 2	I/O	High-order address byte for external memory (A08 to A15)	Port 2 provides the High-order address bus when the P8xC592 is expanded with external Program Memory and/or external Data Memory.
Port 3	I/O	Serial Input Port (RXD)	Receiver input of serial port SIO0 (UART).
		Serial Output Port (TXD)	Transmitter output of serial port SIO0 (UART).
		External interrupt (INT0)	External interrupt request inputs.
		External interrupt (INT1)	
		Timer 0 external input (T0)	Counter inputs.
		Timer 1 external input (T1)	
		External data memory Write strobe ( $\overline{WR}$ )	Control signal to write to external Data Memory.
		External data memory Read strobe ( $\overline{RD}$ )	Control signal to read from external Data Memory.
Port 4	I/O	Compare and Set/Reset outputs (CMSR0 to CMSR5)	Can be configured to provide signals indicating a match between Timer counter T2 and its compare registers.
		Compare and toggle outputs (CMT0, CMT1)	
Port 5	I	Input channels to ADC (ADC7 to ADC0)	Port 5 may be used in conjunction with the ADC interface (note 2).

## 8-bit microcontroller with on-chip CAN

## P8xC592

**Notes to the alternative Port functions**

1. Port lines P1.6 and P1.7 may be selected as CTX0 and CTX1 outputs of the serial port SIO1 (CAN). After reset P1.6 and P1.7 may be used as normal I/O ports, if the CAN interface is not used.
2. Unused analog inputs can be used as digital inputs. As Port 5 lines may be used as inputs to the ADC, these digital inputs have an inherent hysteresis to prevent the input logic from drawing too much current from the power lines when driven by analog signals. Channel-to-channel crosstalk should be taken into consideration when both digital and analog signals are simultaneously input to Port 5 (see Chapter 20).

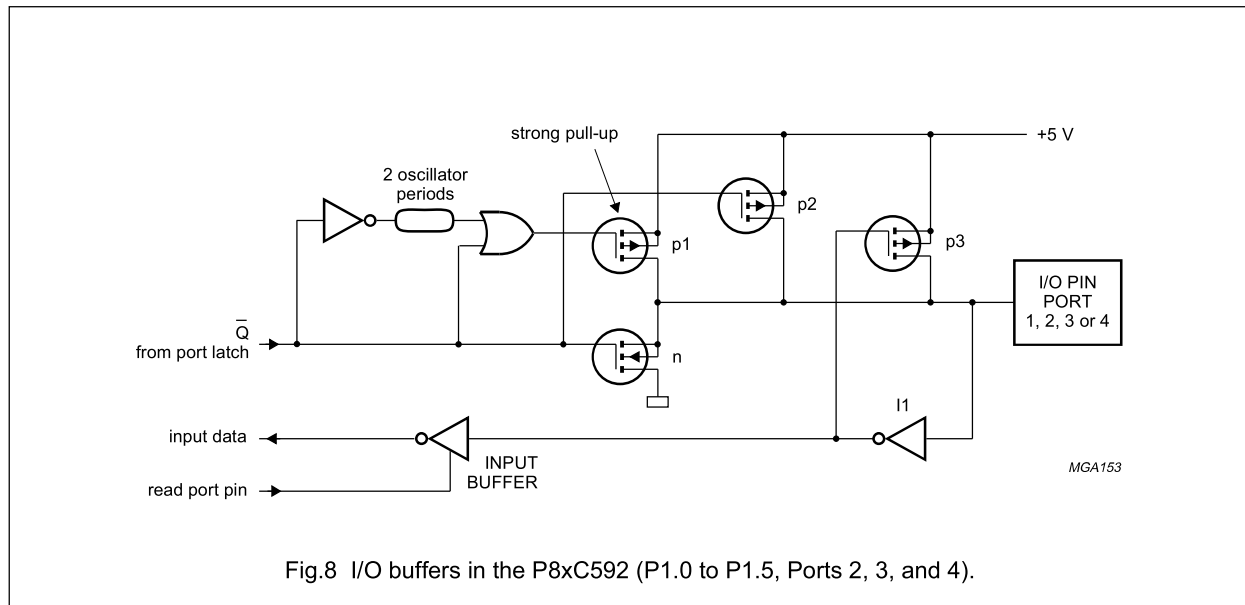
**9 PULSE WIDTH MODULATED OUTPUTS (PWM)**

Two Pulse Width Modulated (PWM) output channels are available with the P8xC592. These channels provide output pulses of programmable length and interval. The repetition frequency is defined by an 8-bit prescaler PWMP which generates the clock for the counter. Both the prescaler and counter are common to both PWM channels. The 8-bit counter counts modulo 255 i.e. from 0 to 254 inclusive. The value of the 8-bit counter is compared to the contents of two registers: PWM0 and PWM1.

Provided the contents of either of these registers is greater than the counter value, the output of  $\overline{\text{PWM0}}$  or  $\overline{\text{PWM1}}$  is set LOW. If the contents of these register are equal to, or less than the counter value, the output will be HIGH. The pulse-width-ratio is therefore defined by the contents of the register PWM0 and PWM1. The pulse-width-ratio is in the range of 0 to  $\frac{255}{255}$  and may be programmed in increments of  $\frac{1}{255}$ .

The repetition frequency  $f_{\text{PWM}}$ , at the  $\overline{\text{PWMn}}$  outputs is

$$\text{given by: } f_{\text{PWM}} = \frac{f_{\text{CLK}}}{2 \times (\text{PWMP} + 1) \times 255}$$

When using an oscillator frequency of 16 MHz, for example, the above formula would give a repetition frequency range of 123 Hz to 31.4 kHz.

By loading the PWM registers with either 00H or FFH, the PWM outputs can be retained at a constant HIGH or LOW level respectively. When loading FFH to the PWM registers, the 8-bit counter will never actually reach this (FFH) value.

Both output pins  $\overline{\text{PWMn}}$  are driven by push-pull drivers, and are not shared with any other function.

## 8-bit microcontroller with on-chip CAN

P8xC592

**9.1 Prescaler frequency control register (PWMP)****Table 7** Prescaler frequency control register (address FEH)

7	6	5	4	3	2	1	0
PWMP.7	PWMP.6	PWMP.5	PWMP.4	PWMP.3	PWMP.2	PWMP.1	PWMP.0

**Table 8** Description of PWMP bits

BIT	SYMBOL	FUNCTION
7 to 0	PWMP.7 to PWMP.0	<b>Prescaler division factor.</b> The Prescaler division factor = (PWMP) + 1.

**9.2 Pulse Width Register 0 (PWM0)****Table 9** Pulse Width Register (address FCH)

7	6	5	4	3	2	1	0
PWM0.7	PWM0.6	PWM0.5	PWM0.4	PWM0.3	PWM0.2	PWM0.1	PWM0.0

**Table 10** Description of PWM0 bits

BIT	SYMBOL	FUNCTION
7 to 0	PWM0.7 to PWM0.0	<b>Pulse width ratio.</b> LOW/HIGH ratio of $\overline{\text{PWMn}}$ signals = $\frac{(\text{PWMn})}{255 - (\text{PWMn})}$

**9.3 Pulse Width Register 1 (PWM1)****Table 11** Pulse width register (address FDH)

7	6	5	4	3	2	1	0
PWM1.7	PWM1.6	PWM1.5	PWM1.4	PWM1.3	PWM1.2	PWM1.1	PWM1.0

**Table 12** Description of PWM1 bits

BIT	SYMBOL	FUNCTION
7 to 0	PWM1.7 to PWM1.0	<b>Pulse width ratio.</b> LOW/HIGH ratio of $\overline{\text{PWMn}}$ signals = $\frac{(\text{PWMn})}{255 - (\text{PWMn})}$



## 8-bit microcontroller with on-chip CAN

## P8xC592

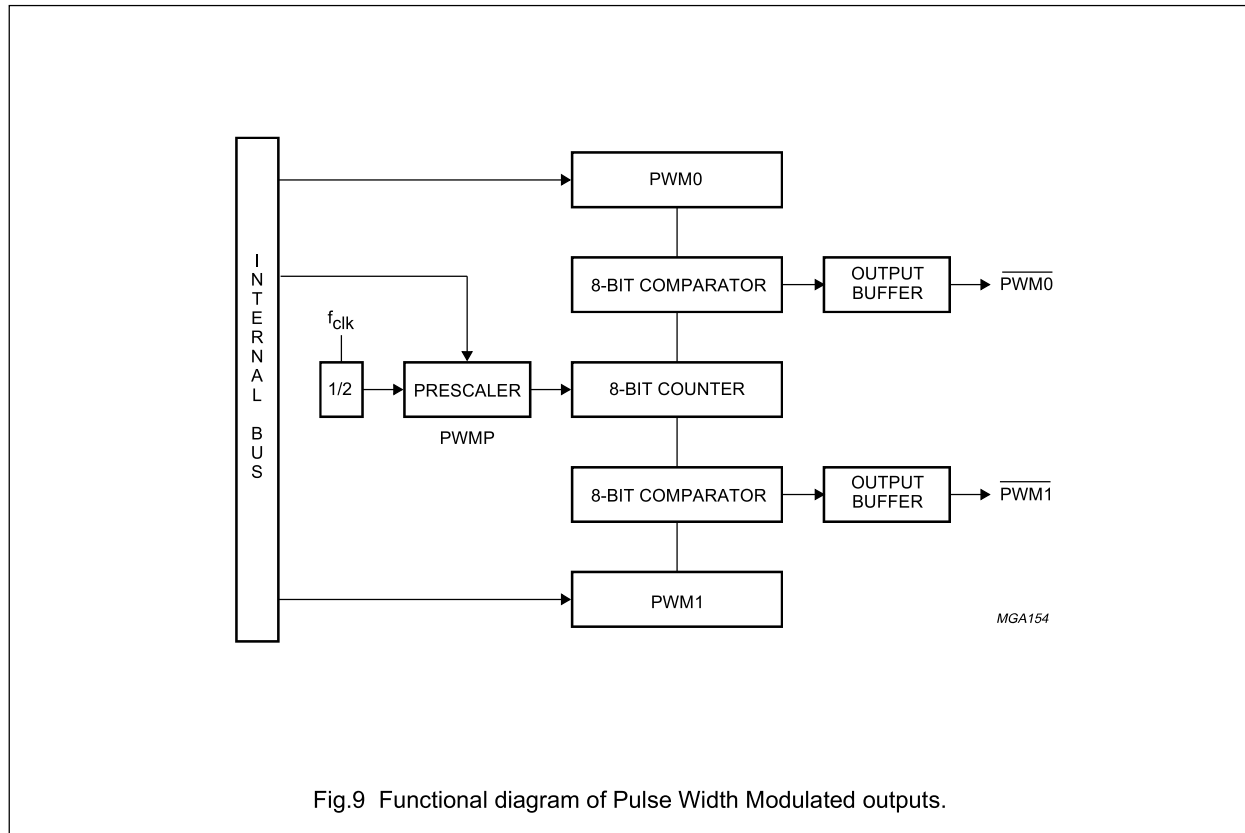

Fig.9 Functional diagram of Pulse Width Modulated outputs.

**10 ANALOG-TO-DIGITAL CONVERTER (ADC)**

The analog input circuitry consists of an 8-input analog multiplexer and an ADC with 10-bit resolution. The analog reference voltage and analog power supplies are connected via separate input pins. The conversion takes 50 machine cycles i.e. 37.5  $\mu$ s at 16 MHz oscillator frequency. The input voltage swing is from 0 V to  $AV_{DD}$ . The ADC is controlled using the ADCON control register. Register bits ADCON.0 to ADCON.2 select the input channels of the analog multiplexer (see Fig.10). The completion of the 10-bit analog-to-digital conversion is flagged by ADCI in the ADCON register and the result is stored in the SFR ADCH (upper 8-bits) and the 2 lower bits (ADC.1 and ADC.0) in register ADCON.

An analog-to-digital conversion in progress is unaffected by an external or software ADC start. The result of a completed conversion remains unchanged provided ADCI = HIGH. While ADCI or ADCS are HIGH, a new ADC START will be blocked and consequently lost. An analog-to-digital conversion already in progress is aborted when the Idle or Power-down mode is entered.

The result of a completed conversion (ADCI = HIGH) remains unaffected during the Idle mode.

The LOW-to-HIGH transition of STADC is recognized at the end of a machine cycle and the conversion commences at the beginning of the next cycle. When a conversion is initiated by software, the conversion starts at the beginning of the machine cycle following the instruction that sets ADCS.

The next two machine cycles are used to initiate the converter. At the end of this first cycle, the ADCS status flag is set to HIGH while the conversion is in progress. Sampling of the analog input commences at the end of the second cycle.

During the next eight machine cycles, the voltage at the previously selected pin of Port 5 is sampled and this input voltage should be stable in order to obtain a useful sample. In any case, the input voltage slew rate must be less than 10 V/ms (5 V conversion range) in order to prevent an undefined result. The conversion takes four machine cycles per bit.

## 8-bit microcontroller with on-chip CAN

P8xC592

**10.1 ADC Control register (ADCON)****Table 13** ADC Control register (address C5H)

7	6	5	4	3	2	1	0
ADC.1	ADC.0	ADEX	ADCI	ADCS	AADR2	AADR1	AADR0

**Table 14** Description of the ADCON bits

BIT	SYMBOL	FUNCTION
7	ADC.1	Bit 1 of ADC converted value.
6	ADC.0	Bit 0 of ADC converted value.
5	ADEX	Enable external start of conversion by STADC. If ADEX is: LOW, then conversion cannot be started externally by STADC (only by software by setting ADCS) HIGH, then conversion can be started externally by a rising edge on STADC or externally.
4	ADCI	<b>ADC interrupt flag.</b> This flag is set when an analog-to-digital conversion result is ready to be read. If enabled, an interrupt is invoked. The flag must be cleared by software. It cannot be set by software (see Table 15).
3	ADCS	<b>ADC start and status.</b> Setting this bit starts an analog-to-digital conversion. It may be set by software or by the external signal STADC. The ADC logic ensures that this signal is HIGH while the ADC is busy. On completion of the conversion, ADCS is reset at the same time the interrupt flag ADCI is set. ADCS can not be reset by software (see Table 15).
2	AADR2	<b>Analog input select.</b> This binary coded address selects one of the eight analog port pins of P5 to be input to the converter. It can only be changed when ADCI and ADCS are both LOW. AADR2 is the MSB. (e.g. 100B selects the analog input channel ADC4)
1	AADR1	
0	AADR0	

**Table 15** ADCI and ADCS operating modes

If ADCI is cleared by software while ADCS is set at the same time a new analog-to-digital conversion with the same channel-number may be started. It is recommended to reset ADCI before ADCS is set.

ADCI	ADCS	OPERATION
0	0	ADC not busy, a conversion can be started.
0	1	ADC busy, start of a new conversion is blocked.
1	X (don't care)	Conversion completed; see note 1.

**Note**

1. Start of a new conversion requires ADCI = 0.

8-bit microcontroller with on-chip CAN

P8xC592

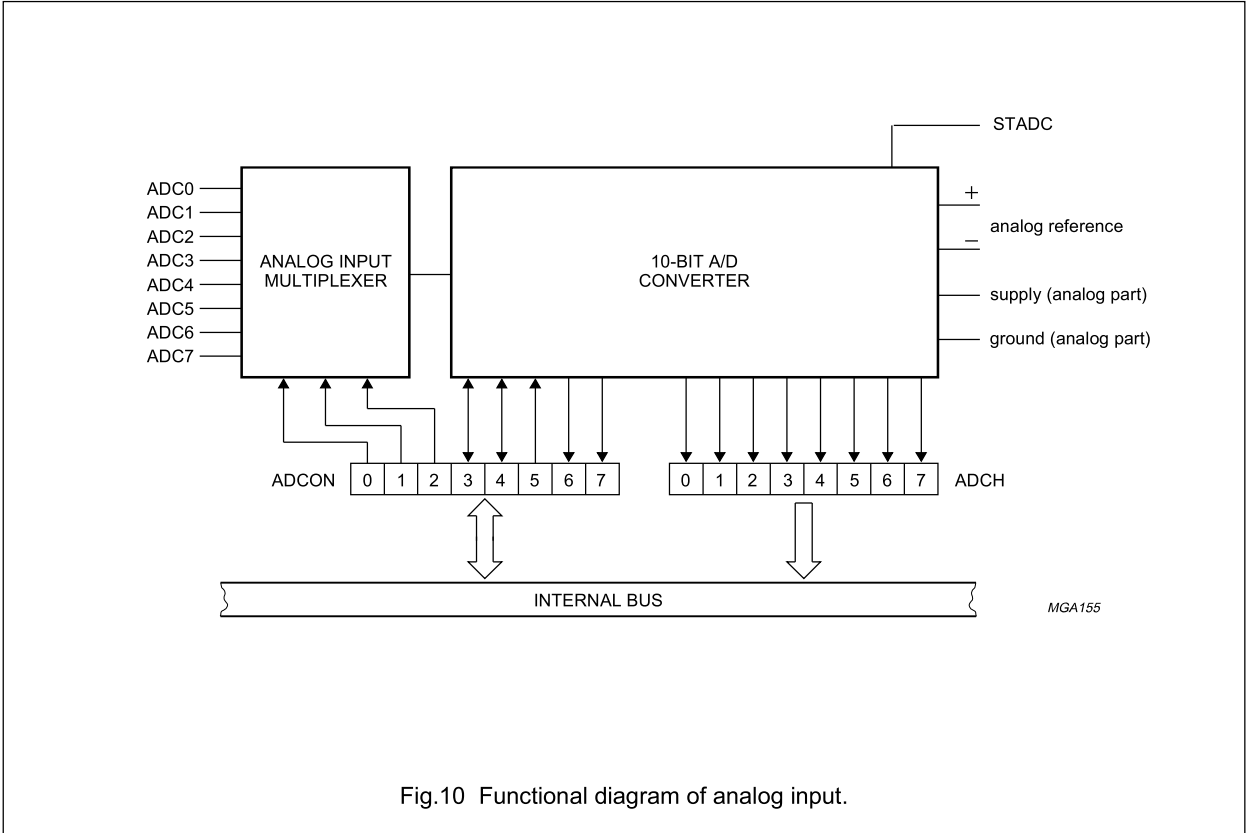

Fig.10 Functional diagram of analog input.

## 8-bit microcontroller with on-chip CAN

## P8xC592

### 11 TIMERS/COUNTERS

The P8xC592 contains:

- Three 16-bit timer/event counters: Timer 0, Timer 1 and Timer 2
- One 8-bit timer, T3 (Watchdog WDT).

#### 11.1 Timer 0 and Timer 1

Timer 0 and Timer 1 may be programmed to carry out the following functions:

- Measure time intervals and pulse durations
- Count events
- Generate interrupt requests.

Timer 0 and Timer 1 can be programmed independently to operate in 3 modes:

Mode 0 8-bit timer or 8-bit counter each with divide-by-32 prescaler.

Mode 1 16-bit timer-interval or event counter.

Mode 2 8-bit timer-interval or event counter with automatic reload upon overflow.

Timer 0 can be programmed to operate in an additional mode as follows:

Mode 3 one 8-bit time-interval or event counter and one 8-bit timer-interval counter.

When Timer 0 is in Mode 3, Timer 1 can be programmed to operate in Modes 0, 1 or 2 but cannot set an interrupt flag or generate an interrupt. However, the overflow from Timer 1 can be used to pulse the Serial Port baud-rate generator.

The frequency handling range of these counters with a 16 MHz crystal is as follows:

- In the timer function, the timer is incremented at a frequency of 1.33 MHz ( $\frac{1}{12}$  of the oscillator frequency)
- 0 Hz to an upper limit of 0.66 MHz ( $\frac{1}{24}$  of the oscillator frequency) when programmed for external inputs.

Both internal and external inputs can be gated to the counter by a second external source for directly measuring pulse durations. When configured as a counter, the register is incremented on every falling edge on the corresponding input pin, T0 or T1.

The earliest moment, when the incremented register value can be read is during the second machine cycle following the machine cycle within which the incrementing pulse occurred. The counters are started and stopped under software control. Each one sets its interrupt request flag

when it overflows from all HIGHs to all LOWs (or automatic reload value), with the exception of Mode 3 as previously described.

#### 11.2 Timer T2 Capture and Compare Logic

Timer T2 is a 16-bit timer/counter which has capture and compare facilities (see Fig.11).

The 16-bit timer/counter is clocked via a prescaler with a programmable division factor of 1, 2, 4 or 8. The input of the prescaler is clocked with  $\frac{1}{12}$  of the oscillator frequency, or by an external source connected to the T2 input, or it is switched off. The maximum repetition rate of the external clock source is  $\frac{1}{12}f_{CLK}$ , twice that of Timer 0 and Timer 1. The prescaler is incremented on a rising edge. It is cleared if its division factor or its input source is changed, or if the timer/counter is reset.

T2 is readable 'on the fly', without any extra read latches; this means that software precautions have to be taken against misinterpretation at overflow from least to most significant byte while T2 is being read. T2 is not loadable and is reset by the RST signal or at the positive edge of the input signal RT2, if enabled. In the Idle mode the timer/counter and prescaler are reset and halted.

T2 is connected to four 16-bit Capture Registers: CT0, CT1, CT2 and CT3. A rising or falling edge on the inputs CT0I, CT1I, CT2I or CT3I (alternative function of Port 1) results in loading the contents of T2 into the respective Capture Registers and an interrupt request.

Using the Capture Register CTCON, these inputs may invoke capture and interrupt request on a positive edge, a negative edge or on both edges. If neither a positive nor a negative edge is selected for capture input, no capture or interrupt request can be generated by this input.

The contents of the Compare Registers CM0, CM1 and CM2 are continually compared with the counter value of Timer T2. When a match occurs, an interrupt may be invoked. A match of CM0 sets the bits 0 to 5 of Port 4, a CM1 match resets these bits and a CM2 match toggles bits 6 and 7 of Port 4, provided these functions are enabled by the STE/RTE registers. A match of CM0 and CM1 at the same time results in resetting bits 0 to 5 of Port 4. CM0, CM1 and CM2 are reset by the RST signal.

Port 4 can be read and written by software without affecting the toggle, set and reset signals. At a byte overflow of the least significant byte, or at a 16-bit overflow of the timer/counter, an interrupt sharing the same interrupt vector is requested. Either one or both of these overflows can be programmed to request an interrupt. All interrupt flags must be reset by software.

8-bit microcontroller with on-chip CAN

P8xC592

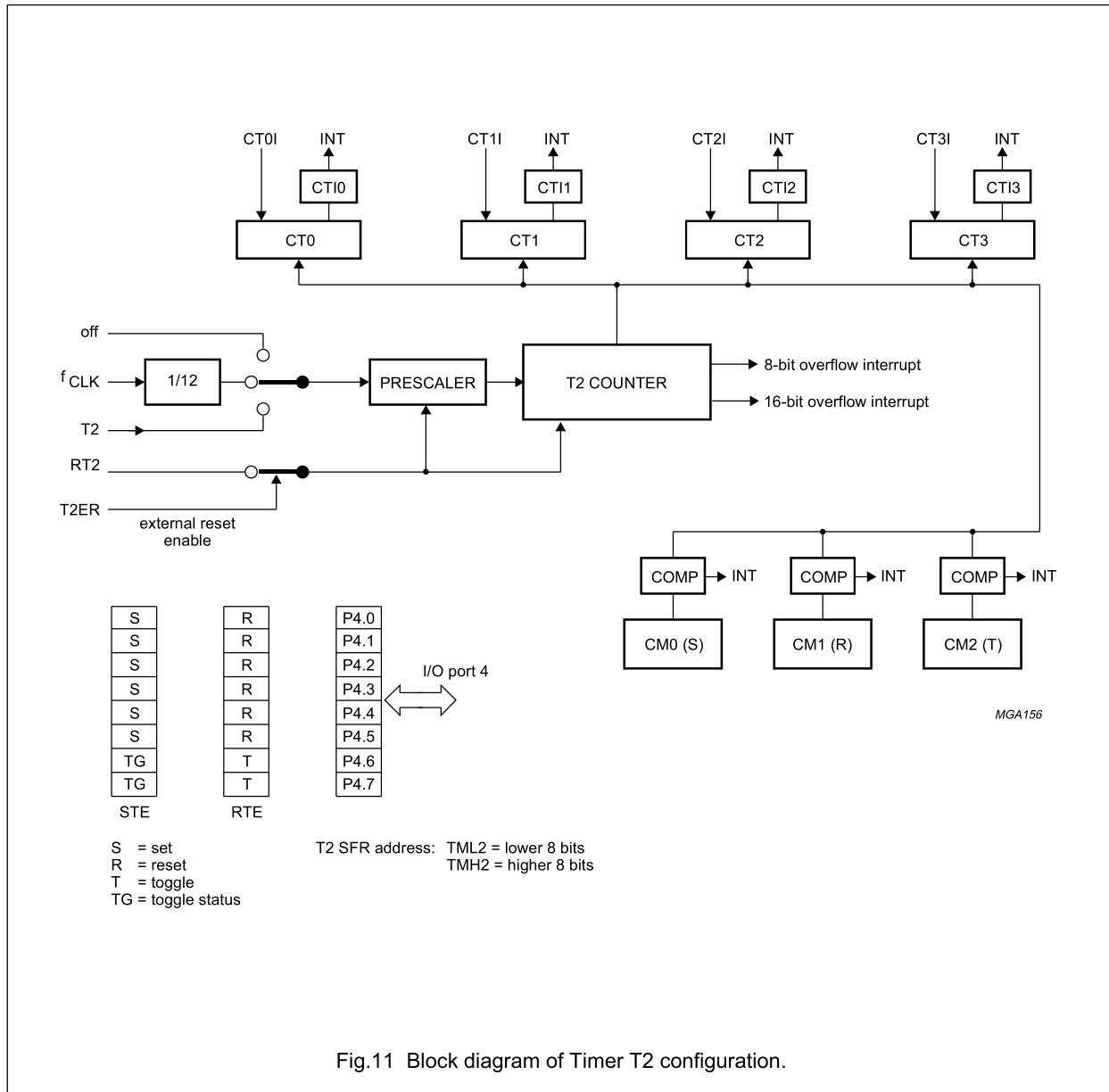

Fig.11 Block diagram of Timer T2 configuration.

## 8-bit microcontroller with on-chip CAN

P8xC592

## 11.2.1 COUNTER CONTROL REGISTER (TM2CON)

**Table 16** Counter Control register (address EAH)

7	6	5	4	3	2	1	0
T2IS1	T2IS0	T2ER	T2B0	T2P1	T2P0	T2MS1	T2MS0

**Table 17** Description of the TM2CON bits

BIT	SYMBOL	FUNCTION
7	T2IS1	Timer 2 16-bit overflow interrupt select.
6	T2IS0	Timer 2 byte overflow interrupt select.
5	T2ER	Timer 2 external reset enable.
4	T2B0	Timer 2 byte overflow interrupt flag.
3	T2P1	Timer 2 prescaler select (see Table 18).
2	T2P0	
1	T2MS1	Timer 2 mode select (see Table 19).
0	T2MS0	

**Table 18** Timer 2 prescaler select

T2P1	T2P0	T2 CLOCK
0	0	Clock source
0	1	$\frac{1}{2}$ Clock source
1	0	$\frac{1}{4}$ Clock source
1	1	$\frac{1}{8}$ Clock source

**Table 19** Timer 2 mode select

T2MS1	T2MS0	MODE
0	0	Timer T2 is halted
0	1	T2 clock source = $\frac{1}{12}f_{CLK}$ .
1	0	Test mode; do not use
1	1	T2 clock source = pin T2

## 11.2.2 CAPTURE CONTROL REGISTER (CTCON)

**Table 20** Capture Control register (address EBH)

7	6	5	4	3	2	1	0
CTN3	CTP3	CTN2	CTP2	CTN1	CTP1	CTN0	CTP0

**Table 21** Description of the CTCON bits

BIT	SYMBOL	FUNCTION	
		CAPTURE	INTERRUPT ON
7	CTN3	CT3I	negative edge
6	CTP3	CT3I	positive edge
5	CTN2	CT2I	negative edge
4	CTP2	CT2I	positive edge
3	CTN1	CT1I	negative edge
2	CTP1	CT1I	positive edge
1	CTN0	CT0I	negative edge
0	CTP0	CT0I	positive edge

## 8-bit microcontroller with on-chip CAN

P8xC592

## 11.2.3 TIMER INTERRUPT FLAG REGISTER (TM2IR)

**Table 22** Timer Interrupt Flag register (address C8H)

7	6	5	4	3	2	1	0
T2OV	CMI2	CMI1	CMI0	CTI3	CTI2	CTI1	CTI0

**Table 23** Description of the TM2IR bits (see notes 1 and 2)

BIT	SYMBOL	FUNCTION
7	T2OV	T2: 16-bit overflow interrupt flag
6	CMI2	CM2: interrupt flag
5	CMI1	CM1: interrupt flag
4	CMI0	CM0: interrupt flag
3	CTI3	CT3: interrupt flag
2	CTI2	CT2: interrupt flag
1	CTI1	CT1: interrupt flag
0	CTI0	CT0: interrupt flag

**Notes**

1. Interrupt Enable IEN1 is used to enable/disable Timer 2 interrupts (see Section 14.1.2).
2. Interrupt Priority Register IP1 is used to determine the Timer 2 interrupt priority (see Section 14.1.4).

## 11.2.4 SET ENABLE REGISTER (STE)

**Table 24** Set Enable register (address EEH)

7	6	5	4	3	2	1	0
TG47	TG46	SP45	SP44	SP43	SP42	SP41	SP40

**Table 25** Description of the STE bits (see notes 1 and 2)

BIT	SYMBOL	FUNCTION
7	TG47	if HIGH then P4.7 is reset on the next toggle, if LOW P4.7 is set on the next toggle
6	TG46	if HIGH then P4.6 is reset on the next toggle, if LOW P4.6 is set on the next toggle
5	SP45	if HIGH then P4.5 is set on a match of CM0 and T2
4	SP44	if HIGH then P4.4 is set on a match of CM0 and T2
3	SP43	if HIGH then P4.3 is set on a match of CM0 and T2
2	SP42	if HIGH then P4.2 is set on a match of CM0 and T2
1	SP41	if HIGH then P4.1 is set on a match of CM0 and T2
0	SP40	if HIGH then P4.0 is set on a match of CM0 and T2

**Notes**

1. If STE.n is LOW then P4.n is not affected by a match of CM0 and T2 (n = 0, 1, 2, 3, 4, 5).
2. STE.6 and STE.7 are read only.

## 8-bit microcontroller with on-chip CAN

## P8xC592

## 11.2.5 RESET/TOGGLE ENABLE REGISTER (RTE)

**Table 26** Reset/Toggle Enable register (address EFH)

7	6	5	4	3	2	1	0
TP47	TP46	RP45	RP44	RP43	RP42	RP41	RP40

**Table 27** Description of the RTE bits (note 1)

BIT	SYMBOL	FUNCTION
7	TP47	if HIGH then P4.7 toggles on a match of CM2 and T2
6	TP46	if HIGH then P4.6 toggles on a match of CM2 and T2
5	RP45	if HIGH then P4.5 is reset on a match of CM1 and T2
4	RP44	if HIGH then P4.4 is reset on a match of CM1 and T2
3	RP43	if HIGH then P4.3 is reset on a match of CM1 and T2
2	RP42	if HIGH then P4.2 is reset on a match of CM1 and T2
1	RP41	if HIGH then P4.1 is reset on a match of CM1 and T2
0	RP40	if HIGH then P4.0 is reset on a match of CM1 and T2

**Note**

1. If RTE.n is LOW then P4.n is not affected by a match of CM1 and T2 or CM2 and T2.  
For more information, refer to the 8051-based "8-bit Microcontrollers Data Handbook IC20".



# 8-bit microcontroller with on-chip CAN

# P8xC592

### 11.3 Watchdog Timer (T3)

In addition to Timer T2 and the standard timers (Timer 0 and Timer 1), a Watchdog Timer (WDT) comprising an 11-bit prescaler and an 8-bit timer (T3) is also provided (see Fig.12).

The timer T3 is incremented every 1.5 ms, derived from the oscillator frequency of 16 MHz by the following

$$\text{formula: } f_{\text{timer}} = \frac{f_{\text{CLK}}}{12 \times 2048}$$

When a timer T3 overflow occurs, the microcontroller is reset and a reset-output-pulse is generated at pin RST. This short output pulse (3 machine cycles) may be suppressed if the RST pin is connected to a capacitor.

To prevent a system reset (by an overflow of the WDT), the user program has to reload T3 within periods that are shorter than the programmed Watchdog time interval.

If the processor suffers a hardware/software malfunction, the software will fail to reload the timer. This failure will produce a reset upon overflow thus preventing the processor running out of control.

The Watchdog Timer can only be reloaded if the condition flag WLE = PCON.4 has been previously set by software. At the moment the counter is loaded the condition flag is automatically cleared.

The timer interval between the timer's reloading and the occurrence of a reset depends on the reloaded value. For example, this may range from 1.5 ms to 0.375 s when using an oscillator frequency of 16 MHz.

In the Idle state the Watchdog Timer and reset circuitry remain active.

The Watchdog Timer (WDT) is controlled by the Enable Watchdog pin ( $\overline{\text{EW}}$ ) (see Table 28).

**Table 28**  $\overline{\text{EW}}$  controlling WDT and Power-down mode

PIN $\overline{\text{EW}}$	WDT	POWER-DOWN MODE
LOW	enabled	disabled
HIGH	disabled	enabled

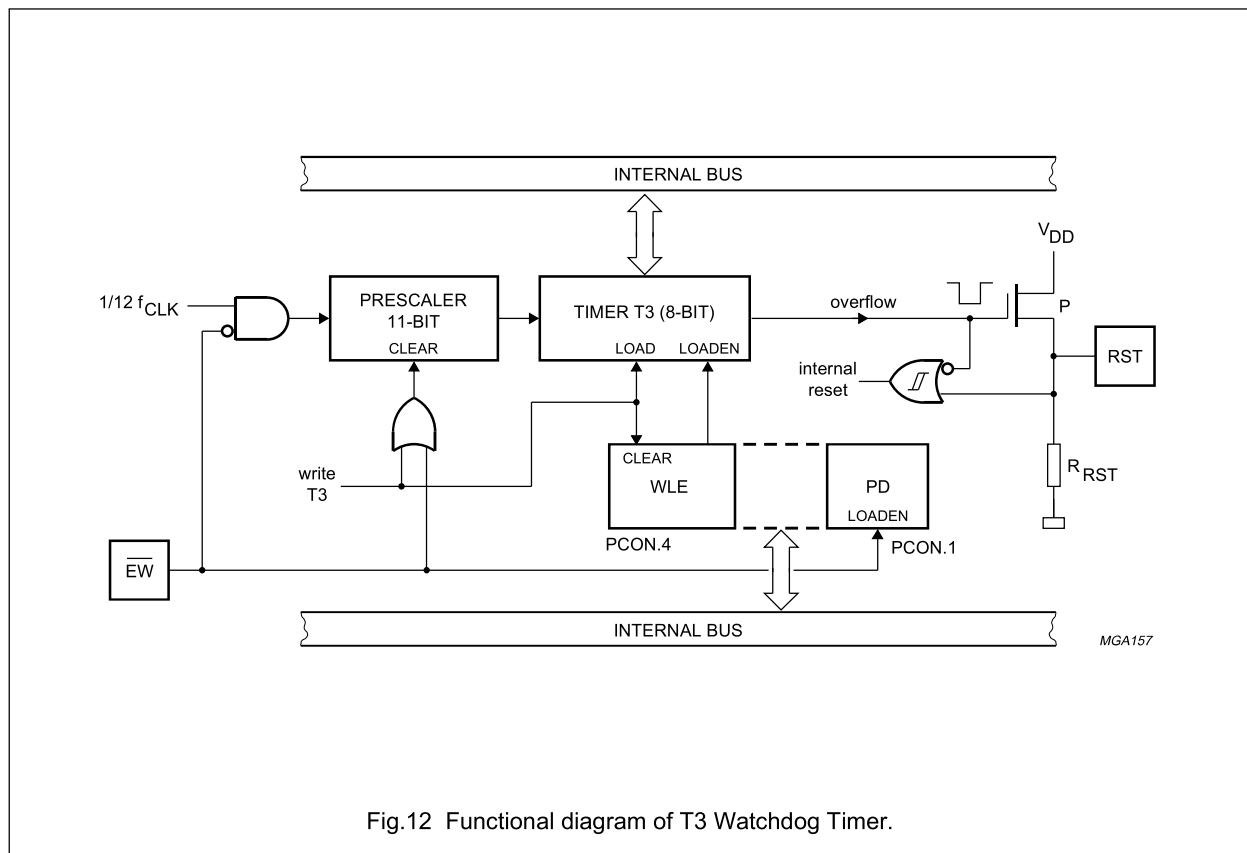

Fig.12 Functional diagram of T3 Watchdog Timer.

## 8-bit microcontroller with on-chip CAN

## P8xC592

### 12 SERIAL I/O PORT: SIO0 (UART)

The Serial Port SIO0 is a full duplex (UART) serial I/O port i.e. it can transmit and receive simultaneously. This Serial Port is also receive-buffered. It can commence reception of a second byte before the previously received byte has been read from the receive register. However, if the first byte has still not been read by the time reception of the second byte is complete, one of these (first or second) bytes will be lost. The SIO0 receive and transmit registers are both accessed via the S0BUF SFR. Writing to S0BUF loads the transmit register, and reading S0BUF accesses to a physically separate receive register. SIO0 can operate in 4 modes:

- Mode 0 Serial data is transmitted and received through RXD. TXD outputs the shift clock. 8 data bits are transmitted/received (LSB first). The baud rate is fixed at  $\frac{1}{12}$  of the oscillator frequency.
- Mode 1 10 bits are transmitted via TXD or received through RXD: a start bit (0), 8 data bits (LSB first), and a stop bit (1). On receive, the stop bit is put into RB8 of the S0CON SFR. The baud rate is variable.
- Mode 2 11 bits are transmitted through TXD or received through RXD: a start bit (0), 8 data bits (LSB first), a programmable 9<sup>th</sup> data bit, and a stop bit (1). On transmit, the 9<sup>th</sup> data bit (TB8 in S0CON) can be assigned the value of 0 or 1. With nominal software, TB8 can be the parity bit (P in PSW). During a receive, the 9<sup>th</sup> data bit is stored in RB8 (S0CON), and the stop bit is ignored. The baud rate is programmable to either  $\frac{1}{32}$  or  $\frac{1}{64}$  of the oscillator frequency.
- Mode 3 11 bits are transmitted through TXD or received through RXD: a start bit (0), 8 data bits (LSB first), a programmable 9<sup>th</sup> data bit, and a stop bit (1). Mode 3 is the same as Mode 2 except for the baud rate which is variable in Mode 3.

In all four modes, transmission is initiated by any instruction that writes to the S0BUF SFR. Reception is initiated in Mode 0 when RI = 0 and REN = 1. In the other three modes, reception is initiated by the incoming start bit provided that REN = 1.

Modes 2 and 3 are provided for multiprocessor communications. In these modes, 9 data bits are received with the 9<sup>th</sup> bit written to RB8 (S0CON). The 9<sup>th</sup> bit is followed by the stop bit. The port can be programmed so that with receiving the stop bit, the Serial Port interrupt will be activated if, and only if RB8 = 1.

This feature is enabled by setting bit SM2 in S0CON. This feature may be used in multiprocessor systems.

For more information about how to use the UART in combination with the registers S0CON, PCON, IE, SBUF and the Timer register, refer to the 8051-based "8-bit Microcontrollers Data Handbook IC20".

### 13 SERIAL I/O PORT: SIO1 (CAN)

SIO1 (CAN) provides the CAN (Controller Area Network) serial-bus data communication interface. SIO1 (CAN) replaces the SIO1 (I<sup>2</sup>C) serial interface as provided in the microcontroller derivative P8xC552.

#### 13.1 On-chip CAN-controller

CAN is the definition of a high performance communication protocol for serial data communication. The P8xC592 on-chip CAN-controller is a full implementation of the CAN 2.0A protocol. With the P8xC592 powerful local networks can be built, both for automotive and general industrial environments. This results in a much reduced wiring harness and enhanced diagnostic and supervisory capabilities.

#### 13.2 CAN Features

- Multi-master architecture
- Bus access priority determined by the message identifier
- 2032 message identifier (2<sup>11</sup> standard frame CAN 2.0A)
- Guaranteed latency time for high priority messages
- Powerful error handling capability
- Data length from 0 up to 8 bytes
- Multicast and broadcast message facility
- Non destructive bit-wise arbitration
- Non-return-to-zero (NRZ) coding/decoding with bit-stuffing
- Programmable transfer rate (up to 1 Mbit/s)
- Programmable output driver configuration
- Suitable for use in a wide range of networks including the SAE's network classes A, B and C
- DMA providing high-speed on-chip data exchange
- Bus failure management facility
- $\frac{1}{2}AV_{DD}$  reference voltage.

## 8-bit microcontroller with on-chip CAN

## P8xC592

**13.3 Interface between CPU and CAN**

The internal interface between the P8xC592's CPU and on-chip CAN-controller is achieved via the following four SFRs (see Fig.13):

- CANADR, to point to a register of the CAN-controller
- CANDAT, to read or write data
- CANCON, to read interrupt flags and to write commands
- CANSTA, to read status information and to write DMA pointer.

Additionally, the DMA-logic allows a high-speed data exchange between the CAN-controller and the CPU's on-chip MAIN RAM. For more information, see Section 13.5.15 "Handling of the CPU-CAN interface".

**13.4 Hardware blocks of the CAN-controller**

The P8xC592 CAN-controller contains all necessary hardware for high performance serial network communications (see Fig.14 and Table 29).

It controls the communication flow through the area network using the CAN-protocol. The CAN-controller meets the following automotive requirements:

- Short message length
- Bus access priority, determined by the message identifier
- Powerful error handling capability
- Configuration flexibility to allow area network expansion
- Guaranteed latency time for urgent messages;
  - The **latency time** defines the period between the initiation (Transmission Request) and the start of the transmission on the bus. The latency time strongly depends on a large variety of bus-related conditions. In the case of a message being transmitted on the bus and one distortion, the latency time can be up to 149 bit times (worst case). For more information see Chapter 22 "CAN application information".

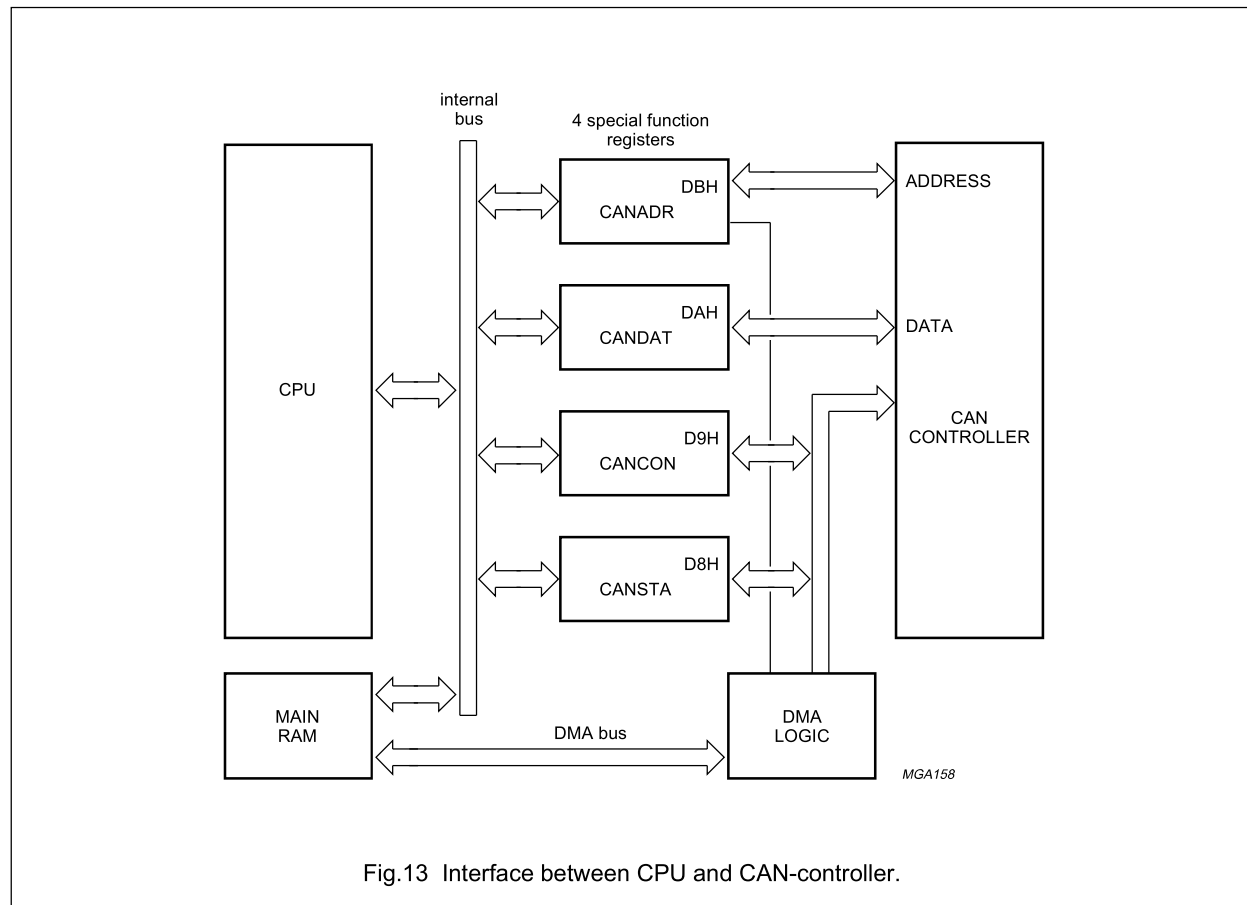

Fig.13 Interface between CPU and CAN-controller.

8-bit microcontroller with on-chip CAN

P8xC592

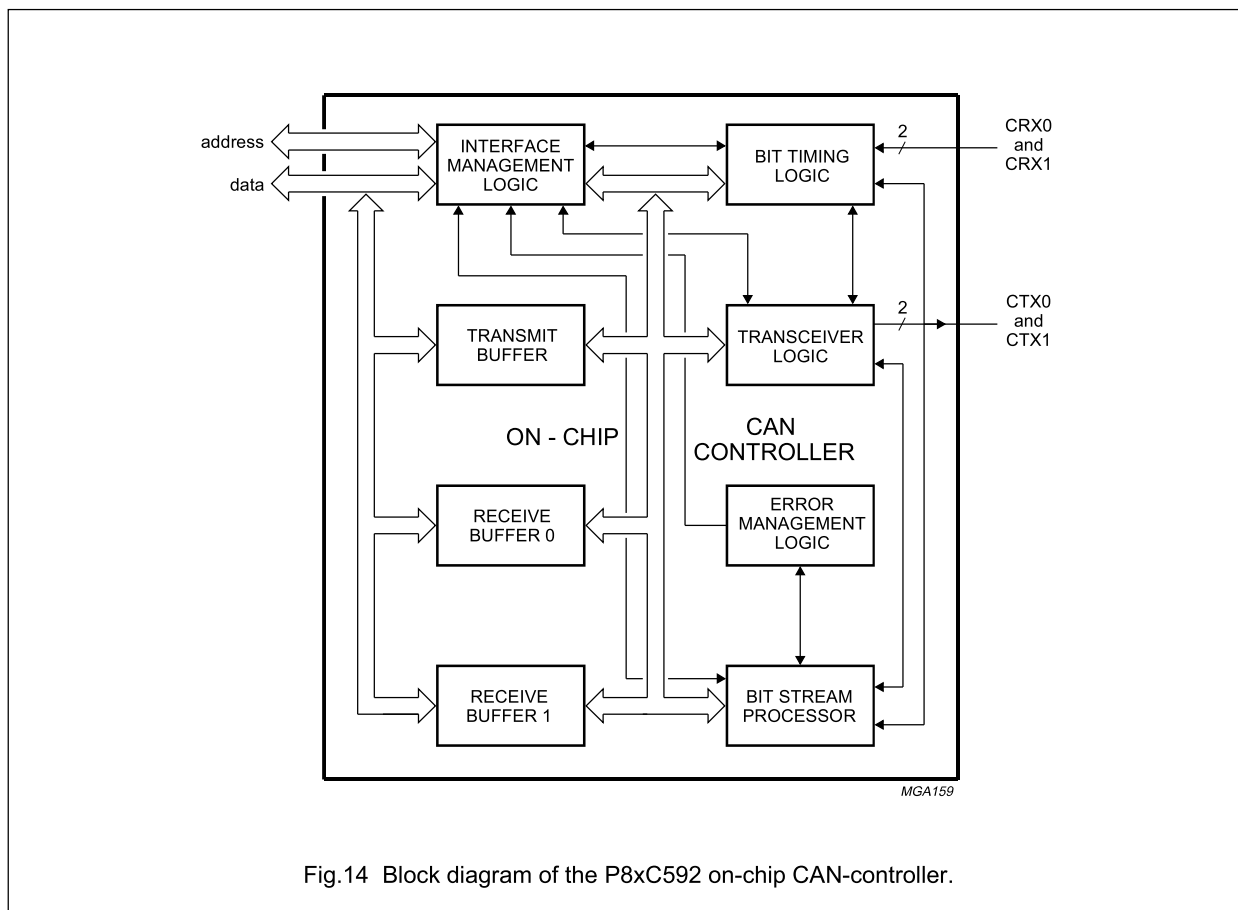

Fig.14 Block diagram of the P8xC592 on-chip CAN-controller.

Table 29 Hardware blocks of the CAN-controller (see Fig.14)

NAME	BLOCK	DESCRIPTION
Interface Management Logic	IML	Interprets commands from the CPU, allocates the message buffers (TBF, RBF0 and RBF1) and provides interrupts and status information to the microcontroller.
Transmit Buffer	TBF	10 bytes memory into which the CPU writes messages which are to be transmitted over the CAN network.
Receive Buffers (0 and 1)	RBF0 RBF1	RBF0 and RBF1 are each 10 bytes memories which are alternatively used to store messages received from the CAN network. The CPU can process one message while another is being received.
Bit Stream Processor	BSP	Is a sequencer, controlling the data stream between the Transmit Buffer, Receive Buffers (parallel data) and the CAN-bus (serial data).
Bit Timing Logic	BTL	Synchronizes the CAN-controller to the bitstream on the CAN-bus.
Transceiver Control Logic	TCL	Controls the output driver.
Error Management Logic	EML	Performs the error confinement according to the CAN-protocol.

# 8-bit microcontroller with on-chip CAN

# P8xC592

## 13.5 Control Segment and Message Buffer description

The CAN-controller appears to the CPU as a memory-mapped peripheral, guaranteeing the independent operation of both parts.

### 13.5.1 ADDRESS ALLOCATION

The address area of the CAN-controller consists of the Control Segment and the message buffers. The Control Segment is programmed during an initialization down-load in order to configure communication parameters (e.g. bit timing). The communication over the CAN-bus is also controlled via this segment by the CPU. A message which is to be transmitted, must be written to the Transmit Buffer.

After a successful reception the CPU may read the message from the Receive Buffer and then release it for further use.

### 13.5.2 CONTROL SEGMENT LAYOUT

The exchange of status, control and command signals between the CPU and the CAN-controller is performed in the control segment. The layout of this segment is shown in Fig.15. After an initial down-load, the contents of the registers Acceptance Code, Acceptance Mask, Bus Timing 0, Bus Timing 1 and Output Control should not be changed. These registers may only be accessed when the Reset Request bit in the Control Register is set HIGH (see Tables 30, 31 and 32).

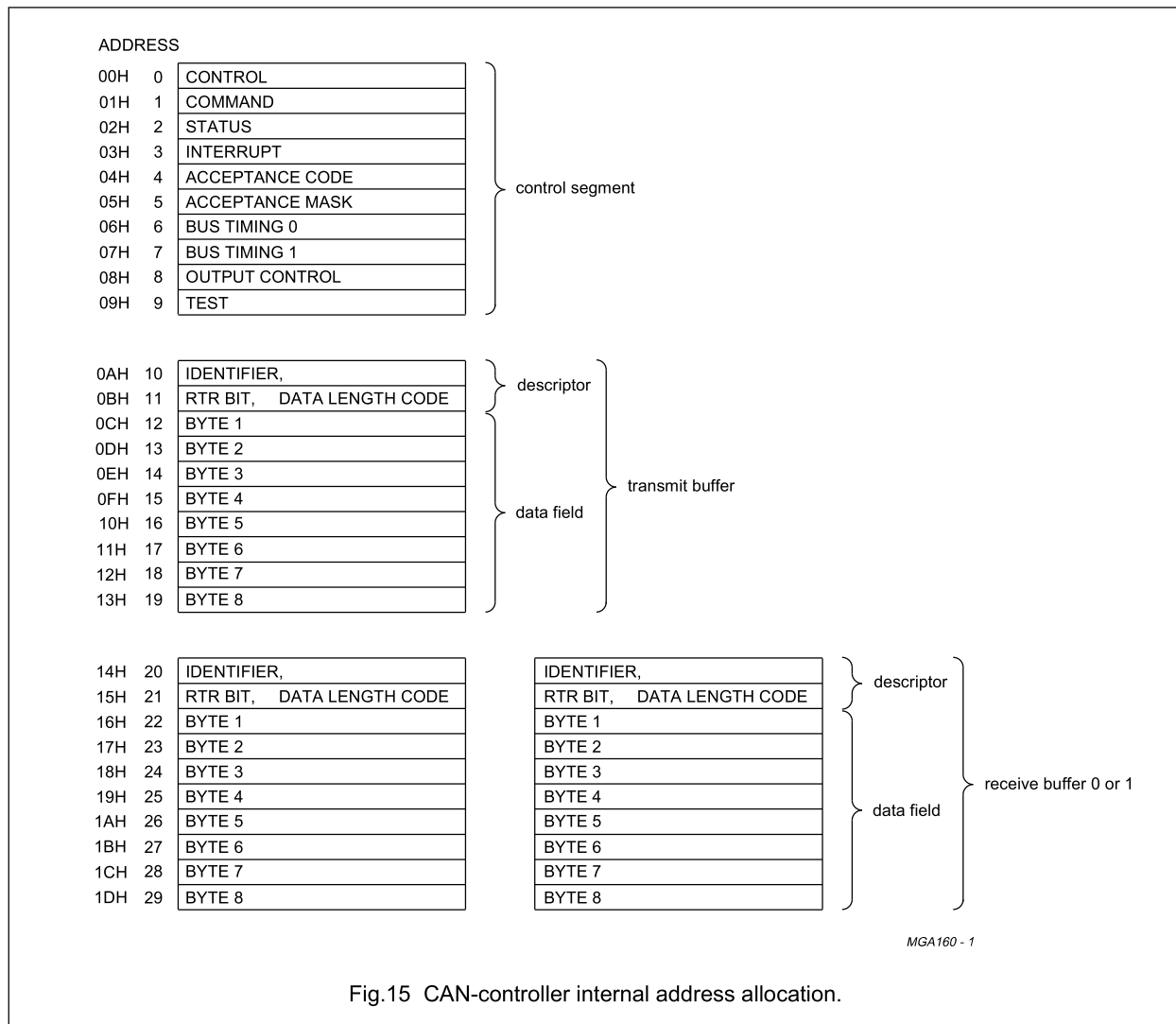

Fig.15 CAN-controller internal address allocation.

## 8-bit microcontroller with on-chip CAN

P8xC592

**Table 30** CPU/CAN Register map

BIT							
7	6	5	4	3	2	1	0
<b>Control Segment</b>							
ADDRESS 0: CONTROL REGISTER							
TM	S	RA	OIE	EIE	TIE	RIE	RR
ADDRESS 1: COMMAND REGISTER							
RX0A	RX1A	WUM	SLP	COS	RRB	AT	TR
ADDRESS 2: STATUS REGISTER							
BS	ES	TS	RS	TCS	TBS	DO	RBS
ADDRESS 3: INTERRUPT REGISTER							
Reserved	Reserved	Reserved	WUI	OI	EI	TI	RI
ADDRESS 4: ACCEPTANCE CODE REGISTER							
AC.7	AC.6	AC.5	AC.4	AC.3	AC.2	AC.1	AC.0
ADDRESS 5: ACCEPTANCE MASK REGISTER							
AM.7	AM.6	AM.5	AM.4	AM.3	AM.2	AM.1	AM.0
ADDRESS 6: BUS TIMING REGISTER 0							
SJW.1	SJW.0	BRP.5	BRP.4	BRP.3	BRP.2	BRP.1	BRP.0
ADDRESS 7: BUS TIMING REGISTER 1							
SAM	TSEG2.2	TSEG2.1	TSEG2.0	TSEG1.3	TSEG1.2	TSEG1.1	TSEG1.0
ADDRESS 8: OUTPUT CONTROL REGISTER							
OCTP1	OCTN1	OCPOL1	OCTP0	OCTN0	OCPOL0	OCMODE1	OCMODE0
ADDRESS 9: TEST REGISTER (note 1)							
Reserved	Reserved	Map Internal Register	Connect RX Buffer 0 CPU	Connect TX Buffer CPU	Access Internal Bus	Normal RAM Connect	Float Output Driver

## 8-bit microcontroller with on-chip CAN

P8xC592

BIT							
7	6	5	4	3	2	1	0
<b>Transmit Buffer</b>							
ADDRESS 10: IDENTIFIER							
ID.10	ID.9	ID.8	ID.7	ID.6	ID.5	ID.4	ID.3
ADDRESS 11: RTR, DATA LENGTH CODE							
ID.2	ID.1	ID.0	RTR	DLC.3	DLC.2	DLC.1	DLC.0
ADDRESS 12 TO 19: BYTES 1 TO 8							
Data	Data	Data	Data	Data	Data	Data	Data
<b>Receive Buffer 0 and 1</b>							
ADDRESS 20: IDENTIFIER							
ID.10	ID.9	ID.8	ID.7	ID.6	ID.5	ID.4	ID.3
ADDRESS 21: RTR, DATA LENGTH CODE							
ID.2	ID.1	ID.0	RTR	DLC.3	DLC.2	DLC.1	DLC.0
ADDRESS 22 TO 29: BYTES 1 TO 8							
Data	Data	Data	Data	Data	Data	Data	Data

**Note**

1. The Test Register is used for production testing only.

## 13.5.3 CONTROL REGISTER (CR)

The contents of the Control Register are used to change the behaviour of the CAN-controller. Control bits may be set or reset by the CPU which uses the Control Register as a read/write memory.

**Table 31** Control Register (address 0)

7	6	5	4	3	2	1	0
TM	S	RA	OIE	EIE	TIE	RIE	RR

**Table 32** Description of the CR bits

BIT	SYMBOL	FUNCTION
7	TM	<b>Test Mode</b> (note 1). If the value of TM is: HIGH (enabled), then the CAN-controller enters Test Mode (normal operations impossible). LOW (disabled), then the CAN-controller is in normal operating mode.
6	S	<b>Sync</b> (note 2). If the value of S is: HIGH (2 edges), then bus-line transitions from recessive-to-dominant and vice-versa are used for resynchronization (see Sections 13.5.20 and 13.6). LOW (1 edge), then the only transitions from recessive-to-dominant are used for resynchronization.

## 8-bit microcontroller with on-chip CAN

P8xC592

BIT	SYMBOL	FUNCTION
5	RA	<b>Reference Active</b> (notes 2). If the value of RA is: HIGH (output), then the pin REF is an $\frac{1}{2}AV_{DD}$ reference output. LOW (input), then a reference voltage may be input.
4	OIE	<b>Overrun Interrupt Enable</b> . If the value of OIE is: HIGH (enabled) and the Data Overrun bit is set (see Section 13.5.5) then the CPU receives an Overrun Interrupt signal. LOW (disabled), then the CPU receives no Overrun Interrupt signal from the CAN-controller.
3	EIE	<b>Error Interrupt Enable</b> . If the value of EIE is: HIGH (enabled) and the Error or Bus Status change (see Section 13.5.5) then the CPU receives an Error Interrupt signal. LOW (disabled), then the CPU receives no Error Interrupt signal.
2	TIE	<b>Transmit Interrupt Enable</b> . If the value of TIE is: HIGH (enabled) and when a message has been successfully transmitted or the Transmit Buffer is accessible again, (e.g. after an Abort Transmission command), then the CAN-controller transmits a Transmit Interrupt signal to the CPU. LOW (disabled), then there is no transmission of the Transmit Interrupt signal by the CAN-controller to the CPU.
1	RIE	<b>Receive Interrupt Enable</b> . If the value of RIE is: HIGH (enabled) and when a message has been received without errors, then the CAN-controller transmits a Receive Interrupt signal to the CPU. LOW (disabled), then there is no transmission of the Receive Interrupt signal by the CAN-controller to the CPU.
0	RR	<b>Reset Request</b> (note 3). If the value of RR is: HIGH (present), then detection of a Reset Request results in the CAN-controller aborting the current transmission/reception of a message entering the reset state synchronously to the system clock ( $t_{SCL}$ , see Section 13.5.9). LOW (absent), on the HIGH-to-LOW transition of the Reset Request bit, the CAN-controller returns to its normal operating state.

**Notes to the description of the CR bits**

- The test mode is intended for factory testing and not for customer use.
- A modification of the bits Reference Active and Sync is only possible with Reset Request = HIGH (present). It is allowed to set these bits while Reset Request is changed from a HIGH level to a LOW level. After an external reset (pin RST = HIGH) the Reference Active bit is set HIGH (output), the Sync bit is undefined.
- During an external reset (RST = HIGH) or when the Bus Status bit is set HIGH (Bus-OFF), the IML forces the Reset Request HIGH (present). After the Reset Request bit is set LOW (absent) the CAN-controller will wait for:
  - One occurrence of the Bus-Free signal (11 recessive bits, see Section 13.6.9.6), if the preceding reset (Reset Request = HIGH) has been caused by an external reset or a CPU initiated reset.
  - 128 occurrences of Bus-Free, if the preceding reset (Reset Request = HIGH) has been caused by a CAN-controller initiated Bus-OFF, before re-entering the Bus-On mode, see Section 13.6.9.
  - When Reset Request is set HIGH (present), for whatever reason, the Control, Command, Status and Interrupt bits are affected, see Table 40. The registers at addresses 4 to 8 are only accessible when the Reset Request is set HIGH (present).



8-bit microcontroller with on-chip CAN

P8xC592

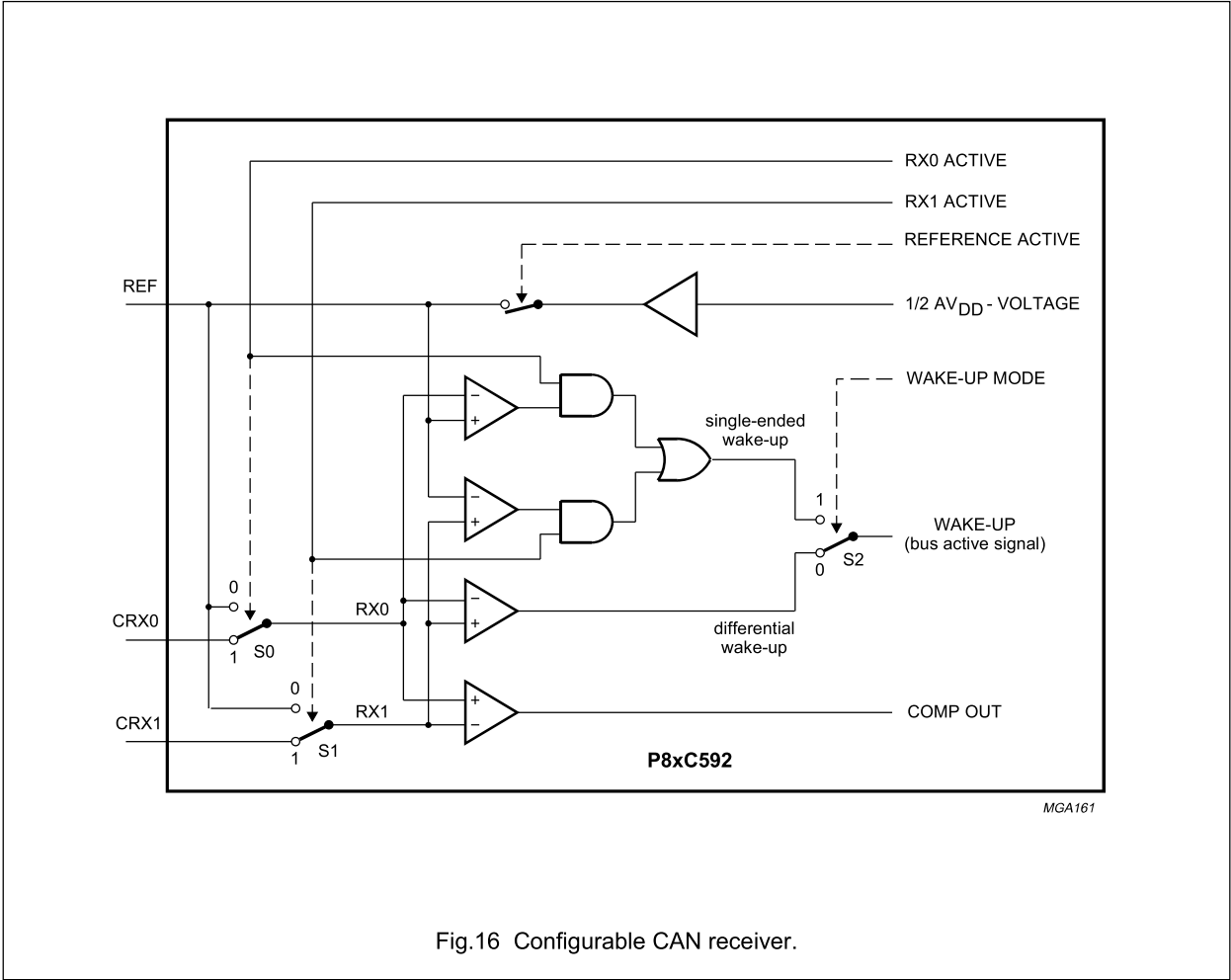

Fig.16 Configurable CAN receiver.

## 8-bit microcontroller with on-chip CAN

P8xC592

## 13.5.4 COMMAND REGISTER (CMR)

A command bit initiates an action within the transfer layer of the CAN-controller. The Command Register appears to the CPU as a read/write memory, except for the bits CMR.0 (TR) to CMR.3 (COS), which return a HIGH if being read.

**Table 33** Command Register (address 1)

7	6	5	4	3	2	1	0
RX0A	RX1A	WUM	SLP	COS	RRB	AT	TR

**Table 34** Description of the CMR bits

BIT	SYMBOL	FUNCTION
7	RX0A	<b>RX0 Active.</b> See Table 35; note 1.
6	RX1A	<b>RX1 Active.</b> See Table 35; note 1.
5	WUM	<b>Wake-up Mode</b> (note 2). If the value of WUM is: HIGH (single ended), then the difference of the RX signals to the internal reference voltage $\frac{1}{2}AV_{DD}$ is used for wake up. LOW (differential), then the differential signal between RX0 and RX1 is used for wake up.
4	SLP	<b>Sleep</b> (note 3). If the value of SLP is: HIGH (sleep), then the CAN-controller enters sleep mode if no CAN interrupt is pending and there is no bus activity. LOW (wake up), then the CAN-controller functions normally.
3	COS	<b>Clear Overrun Status</b> (note 4). If the value of COS is: HIGH (clear), then the Data Overrun status bit is set to LOW (see Table 37). LOW (no action), then there is no action.
2	RRB	<b>Release Receive Buffer</b> (note 5). If the value of RRB is: HIGH (released), then the Receive Buffer attached to the CPU is released. LOW (no action), then there is no action.
1	AT	<b>Abort Transmission</b> (note 6). If the value of AT is: HIGH (present) and if not already in progress, a pending Transmission Request is cancelled. LOW (absent), then there is no action.
0	TR	<b>Transmission Request</b> (note 7). If the value of TR is: HIGH (present), then a message shall be transmitted. LOW (absent), then there is no action.

## 8-bit microcontroller with on-chip CAN

## P8xC592

**Notes to the description of the CMR bits**

1. The RX0/RX1 Active bits, if being read, reflect the status of the respective switches (see Fig. 16). It is recommended to change the switches only during the reset state (Reset Request = HIGH).
2. The Wake-Up Mode bit should be set at the same time as the Sleep bit. The differential wake up mode is useful if both bus wires are fully functioning; it minimizes the amount of wake ups due to noise. The single ended wake up mode is recommended if a wake up must be possible even if one bus wire is already or may become disturbed (see Fig. 16).
3. The CAN-controller will enter sleep mode, if the Sleep bit is set HIGH (sleep) there is no bus activity and no interrupt is pending. The CAN-controller will wake up after the Sleep bit is set LOW (wake up) or when there is bus activity. On wake up, a Wake-Up Interrupt (see Section 13.5.6) is generated (see also Chapter 15). A CAN-controller which is sleeping and then awoken by bus activity will not be able to receive this message until it detects a Bus-Free signal (see Section 13.6.9.6). The Sleep bit, if read, reflects the status of the CAN-controller.
4. This command bit is used to acknowledge the Data Overrun condition signalled by the Data Overrun status bit. Command is given only after releasing both receive buffers. The stored messages have to be rejected. The command bit is set simultaneously with setting of the Release Receive Buffer command bit the second time.
5. After reading the contents of the Receive Buffer (RBF0 or RBF1) the CPU must release this buffer by setting Release Receive Buffer bit HIGH (released). This may result in another message becoming immediately available. To prevent the RRB command being executed only once, the minimum wait time between two successive RRB commands is 3 system clock cycles ( $t_{SCL}$ , see Section 13.5.9).
6. The Abort Transmission bit is used when the CPU requires the suspension of the previously requested transmission, e.g. to transmit an urgent message. A transmission already in progress is not stopped. In order to see if the original message had been either transmitted successfully or aborted, the Transmission Complete Status bit should be checked. This should be done after the Transmit Buffer Access bit has been set HIGH (released) or a Transmit Interrupt has been generated (see Section 13.5.6).
7. If the Transmission Request bit was set HIGH in a previous command, it cannot be cancelled by setting the Transmission Request bit LOW (absent). Cancellation of the requested transmission may be performed by setting the Abort Transmission bit HIGH (present).

**Table 35** Combination of bits RX0A and RX1A (see Fig. 16)

CONTROL		RX0	RX1
RX0A	RX1A		
1	1	CRX0	CRX1
1	0	CRX0	$\frac{1}{2}AV_{DD}$
0	1	$\frac{1}{2}AV_{DD}$	CRX1
0	0	No action	

## 8-bit microcontroller with on-chip CAN

## P8xC592

## 13.5.5 STATUS REGISTER (SR)

The contents of the Status Register reflects the status of the CAN-controller. The Status Register appears to the CPU as a read only memory.

**Table 36** Status Register (address 2)

7	6	5	4	3	2	1	0
BS	ES	TS	RS	TCS	TBS	DO	RBS

**Table 37** Description of the SR bits

BIT	SYMBOL	FUNCTION
7	BS	<b>Bus Status</b> (note 1). If the value of BS is: HIGH (Bus-OFF), then the CAN-controller is not involved in bus activities. LOW (Bus-ON), then the CAN-controller is involved in bus activities.
6	ES	<b>Error Status</b> . If the value of ES is: HIGH (error), then at least one of the Error Counters (see Section 13.6.10) has reached the CPU Warning limit. LOW (ok), then both Error Counters have not reached the warning limit.
5	TS	<b>Transmit Status</b> (note 2). If the value of TS is: HIGH (transmit), then the CAN-controller is transmitting a message. LOW (idle), then no message is transmitted.
4	RS	<b>Receive Status</b> (note 2). If the value of RS is: HIGH (receive), then the CAN-controller is receiving a message. LOW (idle), then no message is received.
3	TCS	<b>Transmission Complete Status</b> (note 3). If the value of TCS is: HIGH (complete), then last requested transmission has been successfully completed. LOW (incomplete), then previously requested transmission is not yet completed.
2	TBS	<b>Transmit Buffer Access</b> (note 3). If the value of TBS is: HIGH (released), then the CPU may write a message into the TBF. LOW (locked), then the CPU cannot access the Transmit Buffer. A message is either waiting for transmission or is in the process of being transmitted.
1	DO	<b>Data Overrun</b> (note 4). If the value of DO is: HIGH (overrun), then both Receive Buffers are full and the first byte of another message should be stored. LOW (absent), then no data overrun has occurred since the Clear Overrun command was given.
0	RBS	<b>Receive Buffer Status</b> (note 5). If the value of RBS is HIGH (full), then this bit is set when a new message is available. LOW (empty), then no message has become available since the last Release Receive Buffer command bit was set.

---

## 8-bit microcontroller with on-chip CAN

P8xC592

---

### Notes to the description of the SR bits

1. When the Bus Status bit is set HIGH (Bus-OFF), the CAN-controller will set the Reset Request bit HIGH (present). It will stay in this state until the CPU sets the Reset Request bit LOW (absent). Once this is completed the CAN-controller will wait the minimum protocol-defined time (128 occurrences of the Bus-Free signal) before setting the Bus Status bit LOW (Bus-ON), the Error Status bit LOW (ok) and resetting the Error Counters. During Bus-OFF the output drivers are switched off (floating); external transceiver circuits should output a recessive level in this case.
2. If both the Receive Status and Transmit Status bits are LOW (idle) the CAN-bus is idle.
3. If the CPU tries to write to the Transmit Buffer when the Transmit Buffer Access bit is LOW (locked), the written bytes will not be accepted and will be lost without this being signalled. The Transmission Complete Status bit is set LOW (incomplete) whenever the Transmission Request bit is set HIGH (present). If an Abort Transmission command is issued, the Transmit Buffer will be released. If the message, which was requested and then aborted, was not transmitted, the Transmission Complete Status bit will remain LOW.
4. If Data Overrun = HIGH (overrun) is detected, the currently received message is dropped. A transmitted message, granted acceptance, is also stored in a Receive Buffer. This occurs because it is not known if the CAN-controller will lose arbitration and so become a receiver of the message. If no Receive Buffer is available, Data Overrun is signalled. However, this transmitted and accepted message does neither cause a Receive Interrupt nor set the Receive Buffer Status bit to HIGH (full). Also, a Data Overrun does not cause the transmission of an Overload Frame (see Sections 13.6.1 and 13.6.5).
5. If the command bit Release Receive Buffer is set HIGH (released) by the CPU, the Receive Buffer Status bit is set LOW (empty) by IML. When a new message is stored in any of the receive buffers, the Receive Buffer Status bit is set HIGH (full) again.

## 8-bit microcontroller with on-chip CAN

## P8xC592

## 13.5.6 INTERRUPT REGISTER (IR)

The Interrupt Register allows the identification of an interrupt source. When one or more bits of this register are set, a CAN interrupt (SI01) will be indicated to the CPU. All bits are reset by the CAN-controller after this register is read by the CPU. This register appears to the CPU as a read only memory.

**Table 38** Interrupt Register (address 3)

7	6	5	4	3	2	1	0
–	–	–	WUI	OI	EI	TI	RI

**Table 39** Description of the IR bits

BIT	SYMBOL	FUNCTION
7	–	Reserved.
6	–	Reserved.
5	–	Reserved.
4	WUI	<b>Wake-Up Interrupt.</b> The value of WUI is set to: HIGH (set), when the sleep mode is left. See Section 13.5.4. LOW (reset), by a read access of the Interrupt Register by the CPU.
3	OI	<b>Overrun Interrupt</b> (note 1). The value of OI is set to: HIGH (set), if both Receive Buffers contain a message and the first byte of another message should be stored (passed acceptance), and the Overrun Interrupt Enable is HIGH (enabled). LOW (reset), by a read access of the Interrupt Register by the CPU.
2	EI	<b>Error Interrupt.</b> The value of EI is set to: HIGH (set), on a change of either the Error Status or Bus Status bits, if the Error Interrupt Enable is HIGH (enabled). See Section 13.5.5. LOW (reset), by a read access of the Interrupt Register by the CPU.
1	TI	<b>Transmit Interrupt.</b> The value of TI is set to: HIGH (set), on a change of the Transmit Buffer Access from LOW to HIGH (released) and Transmit Interrupt Enable is HIGH (enabled). LOW (reset), after a read access of the Interrupt Register by the CPU.
0	RI	<b>Receive Interrupt</b> (note 2). The value of RBS is set to: HIGH (set), when a new message is available in the Receive Buffer and the Receive Interrupt Enable bit is HIGH (enabled). LOW (reset) automatically by a read access of Interrupt Register by the CPU.

**Notes**

1. Overrun Interrupt bit (if enabled) and Data Overrun bit (see Section 13.5.5) are set at the same time.
2. Receive Interrupt bit (if enabled) and Receive Buffer Status bit (see Section 13.5.5) are set at the same time.

## 8-bit microcontroller with on-chip CAN

P8xC592

**Table 40** Effects of setting the Reset Request bit HIGH (present)

TYPE	BIT	SYMBOL	FUNCTION	EFFECT
Control	CR.7	TM	Test Mode	LOW (disabled)
	CR.5	RA	Reference Active	HIGH (output); note 1
Command	CMR.7	RX0A	RX0 Active	HIGH (RX0 = CRX0); note 1
	CMR.6	RX1A	RX1 Active	HIGH (RX1 = CRX1); note 1
	CMR.4	SLP	Sleep	LOW (wake-up)
	CMR.3	COS	Clear Overrun Status	HIGH (clear)
	CMR.2	RRB	Release Receive Buffer	HIGH (released)
	CMR.1	AT	Abort Transmission	LOW (absent)
	CMR.0	TR	Transmission Request	LOW (absent)
Status	SR.7	BS	Bus Status	LOW (Bus-On); note 1
	SR.6	ES	Error Status	LOW (no error); note 1
	SR.5	TS	Transmit Status	LOW (idle)
	SR.4	RS	Receive Status	LOW (idle)
	SR.3	TCS	Transmission Complete Status	HIGH (complete)
	SR.2	TBS	Transmit Buffer Access	HIGH (released)
	SR.1	DO	Data Overrun	LOW (absent)
	SR.0	RBS	Receive Buffer Status	LOW (empty)
Interrupt	IR.3	OI	Overrun Interrupt	LOW (reset)
	IR.1	TI	Transmit Interrupt	LOW (reset)
	IR.0	RI	Receive Interrupt	LOW (reset)

**Note**

1. Only after an external reset; see note 5 to Table 37 "Description of the SR bits".

## 8-bit microcontroller with on-chip CAN

## P8xC592

## 13.5.7 ACCEPTANCE CODE REGISTER (ACR)

The Acceptance Code Register is part of the acceptance filter of the CAN-controller. This register can be accessed (read/write), if the Reset Request bit is set HIGH (present).

When a message is received which passes the acceptance test and if there is an empty Receive Buffer, then the respective Descriptor and Data Field (see Fig.15) are sequentially stored in this empty buffer.

In the event that there is no empty Receive Buffer, the Data Overrun bit is set HIGH (overrun); see Sections 13.5.5 and 13.5.6.

When the complete message has been correctly received the following occurs:

- The Receive Buffer Status bit is set HIGH (full)
- If the Receive Interrupt Enable bit is set HIGH (enabled), the Receive Interrupt is set HIGH (set).

During transmission of a message which passes the acceptance test, the message is also written to its own Receive Buffer. If no Receiver Buffer is available, Data Overrun is signalled because it is not known at the start of a message whether the CAN-controller will lose arbitration and so become a receiver of the message.

**Table 41** Acceptance Code Register (address 4)

7	6	5	4	3	2	1	0
AC.7	AC.6	AC.5	AC.4	AC.3	AC.2	AC.1	AC.0

**Table 42** Description of the ACR bits

BIT	SYMBOL	FUNCTION
7 to 0	AC.7 to AC.0	<b>Acceptance Code.</b> The Acceptance Code bits (AC.7 to AC.0) and the eight most significant bits of the message's Identifier (ID.10 to ID.3) must be equal to those bit positions which are marked relevant by the Acceptance Mask bits (AM.7 to AM.0). The acceptance is given, if the following equation is satisfied: $(ID_{10} \dots ID_3) = [(AC.7 \dots AC.0) \text{ or } (AM.7 \dots AM.0)] = 1111\ 1111\ B.$

## 13.5.8 ACCEPTANCE MASK REGISTER (AMR)

The Acceptance Mask Register is part of the acceptance filter of the CAN-controller.

This register can be accessed (read/write) if the Reset Request bit is set HIGH (present).

The Acceptance Mask Register qualifies which of the corresponding bits of the acceptance code are 'relevant' or 'don't care' for acceptance filtering.

**Table 43** Acceptance Mask Register (address 5)

7	6	5	4	3	2	1	0
AM.7	AM.6	AM.5	AM.4	AM.3	AM.2	AM.1	AM.0

**Table 44** Description of the AMR bits

BIT	SYMBOL	FUNCTION
7 to 0	AM.7 to AM.0	<b>Acceptance Mask.</b> If the Acceptance Mask bit is: HIGH (don't care), then this bit position is 'don't care' for the acceptance of a message. LOW (relevant), then this bit position is 'relevant' for acceptance filtering.



## 8-bit microcontroller with on-chip CAN

## P8xC592

## 13.5.9 BUS TIMING REGISTER 0 (BTR0)

The contents of Bus Timing Register 0 defines the values of the Baud Rate Prescaler (BRP) and the Synchronization Jump Width (SJW).

This register can be accessed (read/write) if the Reset Request bit is set HIGH (present).

For further information on bus timing, see Sections 13.5.10 and 13.5.18.

**Table 45** Bus Timing Register 0 (address 6)

7	6	5	4	3	2	1	0
SJW.1	SJW.0	BRP.5	BRP.4	BRP.3	BRP.2	BRP.1	BRP.0

**Table 46** Description of the BTR0 bits

BIT	SYMBOL	FUNCTION
7	SJW.1	<b>Synchronization Jump Width.</b> To compensate for phase shifts between clock oscillators of different bus controllers, any bus controller must resynchronize on any relevant signal edge of the current transmission. The synchronization jump width defines the maximum number of clock cycles a bit period may be shortened or lengthened by one resynchronization: $t_{SJW} = t_{SCL} (2SJW.1 + SJW.0 + 1)$ .
6	SJW.0	
5	BRP.5	<b>Baud Rate Prescaler.</b> The period of the system clock $t_{SCL}$ is programmable and determines the individual bit timing. The system clock is calculated using the following equation: $t_{SCL} = 2t_{CLK} (32BRP.5 + 16BRP.4 + 8BRP.3 + 4BRP.2 + 2BRP.1 + BRP.0 + 1)$ . Where $t_{CLK}$ = time period of the P8xC592 oscillator.
4	BRP.4	
3	BRP.3	
2	BRP.2	
1	BRP.1	
0	BRP.0	

## 8-bit microcontroller with on-chip CAN

## P8xC592

## 13.5.10 BUS TIMING REGISTER 1(BTR1)

The contents of Bus Timing Register 1 defines the length of the bit period, the location of the sample point and the number of samples to be taken at each sample point.

This register can be accessed (read/write) if the Reset Request bit is set HIGH (present). For further information on bus timing, see Sections 13.5.9 and 13.5.18.

**Table 47** Bus Timing Register 1 (address 7)

7	6	5	4	3	2	1	0
SAM	TSEG2.2	TSEG2.1	TSEG2.0	TSEG1.3	TSEG1.2	TSEG1.1	TSEG1.0

**Table 48** Description of the BTR1 bits

BIT	SYMBOL	FUNCTION
7	SAM	<p><b>Sampling.</b> If the bit SAM is:</p> <p>HIGH (3 samples), then three samples are taken. This is recommended for slow/medium speed buses (SAE class A and B) where filtering of spikes on the bus-line is beneficial (see Section 13.5.19.6)</p> <p>LOW (1 sample), the bus is sampled once.</p> <p>This is recommended for high speed buses (SAE class C).</p>
6	TSEG2.2	<p><b>Time Segment 1 (TSEG1) and Time Segment 2 (TSEG2).</b></p> <p>TSEG1 determines the number of clock cycles per bit period and the location of the sample point</p> $t_{TSEG1} = t_{SCL} (8TSEG1.3 + 4TSEG1.2 + 2TSEG1.1 + TSEG1.0 + 1).$ <p>TSEG2 determines the number of clock cycles per bit period and the location of the sample point:</p> $t_{TSEG2} = t_{SCL} (4TSEG2.2 + 2TSEG2.1 + TSEG2.0 + 1) .$
5	TSEG2.1	
4	TSEG2.0	
3	TSEG1.3	
2	TSEG1.2	
1	TSEG1.1	
0	TSEG1.0	

## 8-bit microcontroller with on-chip CAN

## P8xC592

## 13.5.11 OUTPUT CONTROL REGISTER (OCR)

The Output Control Register allows, under software control, the set-up of different output driver configurations. This register can be accessed (read/write) if the Reset Request bit is set HIGH (present). If the CAN-controller is in the sleep mode (Sleep = HIGH) a recessive level is output on the CTX0 and CTX1 pins. If the CAN-controller

is in the reset state (Reset Request = HIGH) the output drivers are floating.

Tables 50 and 51, show the relationship between the bits of the Output Control Register and the two serial output pins CTX0 and CTX1 of the P8xC592 CAN-controller, connected to the serial bus (see Fig.14).

**Table 49** Output Control Register (address 8)

7	6	5	4	3	2	1	0
OCTP1	OCTN1	OCPOL1	OCTP0	OCTN0	OCPOL0	OCMODE1	OCMODE0

**Table 50** Description of the OCR bits

BIT	SYMBOL	FUNCTION
7	OCTP1	See Tables 51 and 52.
6	OCTN1	
5	OCPOL1	
4	OCTP0	
3	OCTN0	
2	OCPOL0	
1	OCMODE1	<b>Output Mode.</b>
0	OCMODE0	These bits select the output mode; see Table 51.

**Table 51** Description of the Output Mode bits

OCMODE1	OCMODE0	DESCRIPTION
1	0	<b>Normal Output Mode.</b> The bit sequence (TXD) is sent via CTX0, CTX1. TXD is the data bit to be transmitted. The voltage levels on the output driver pins CTX0 and CTX1 depend on both the driver characteristic programmed by OCTPx, OCTNx (float, pull-up, pull-down, push-pull) and the output polarity programmed by OCPOLx (see Fig.17).
1	1	<b>Clock Output Mode.</b> For the CTX0 pin this is the same as in Normal Output Mode (CTX0: bit sequence). However, the data stream to CTX1 is replaced by the transmit clock (TXCLK). The rising edge of the transmit clock (non-inverted) marks the beginning of a bit period. The clock pulse width is $t_{SCL}$ .
0	0	<b>Bi-phase Output Mode.</b> In contrast to Normal Output Mode the bit representation is time variant and toggled. If the bus controllers are galvanically decoupled from the bus-line by a transformer, the bit stream is not allowed to contain a DC component. This is achieved by the following scheme. During recessive bits all outputs are deactivated (floating). Dominant bits are sent alternately on CTX0 and CTX1, i.e. the first dominant bit is sent on CTX0, the second is sent on CTX1, and the third one is sent on CTX0 again, etc.
0	1	<b>Test Output Mode.</b> For the CTX0 pin this is the same as in Normal Output Mode (CTX0: bit sequence). To measure the delay time of the transmitter and receiver this mode connects the output of the input comparator (COMP OUT) with the input of the output driver CTX1. This mode is used for production testing only.

8-bit microcontroller with on-chip CAN

P8xC592

**Table 52** Output pin set-up

DRIVE	OCTP <sub>x</sub>	OCTN <sub>x</sub>	OCPOL <sub>x</sub>	TXD	TP <sub>x</sub> <sup>(1)</sup>	TN <sub>x</sub> <sup>(2)</sup>	CTX <sub>x</sub> <sup>(3)</sup>
Float	0	0	0	0	OFF	OFF	float
	0	0	0	1	OFF	OFF	float
	0	0	1	0	OFF	OFF	float
	0	0	1	1	OFF	OFF	float
Pull-down	0	1	0	0	OFF	ON	LOW
	0	1	0	1	OFF	OFF	float
	0	1	1	0	OFF	OFF	float
	0	1	1	1	OFF	ON	LOW
Pull-up	1	0	0	0	OFF	OFF	float
	1	0	0	1	ON	OFF	HIGH
	1	0	1	0	ON	OFF	HIGH
	1	0	1	1	OFF	OFF	float
Push/Pull	1	1	0	0	OFF	ON	LOW
	1	1	0	1	ON	OFF	HIGH
	1	1	1	0	ON	OFF	HIGH
	1	1	1	1	OFF	ON	LOW

**Notes**

1. TP<sub>x</sub> is the on-chip output transistor x, connected to V<sub>DD</sub>; x = 0 or 1.
2. TN<sub>x</sub> is the on-chip output transistor x, connected to CV<sub>SS</sub>; x = 0 or 1.
3. CTX<sub>x</sub> is the serial output level on CTX0 or CTX1. It is required that the output level on the CAN-bus is dominant with TXD = 0 and recessive with TXD = 1, see Section 13.6.1.1 "Bit representation".

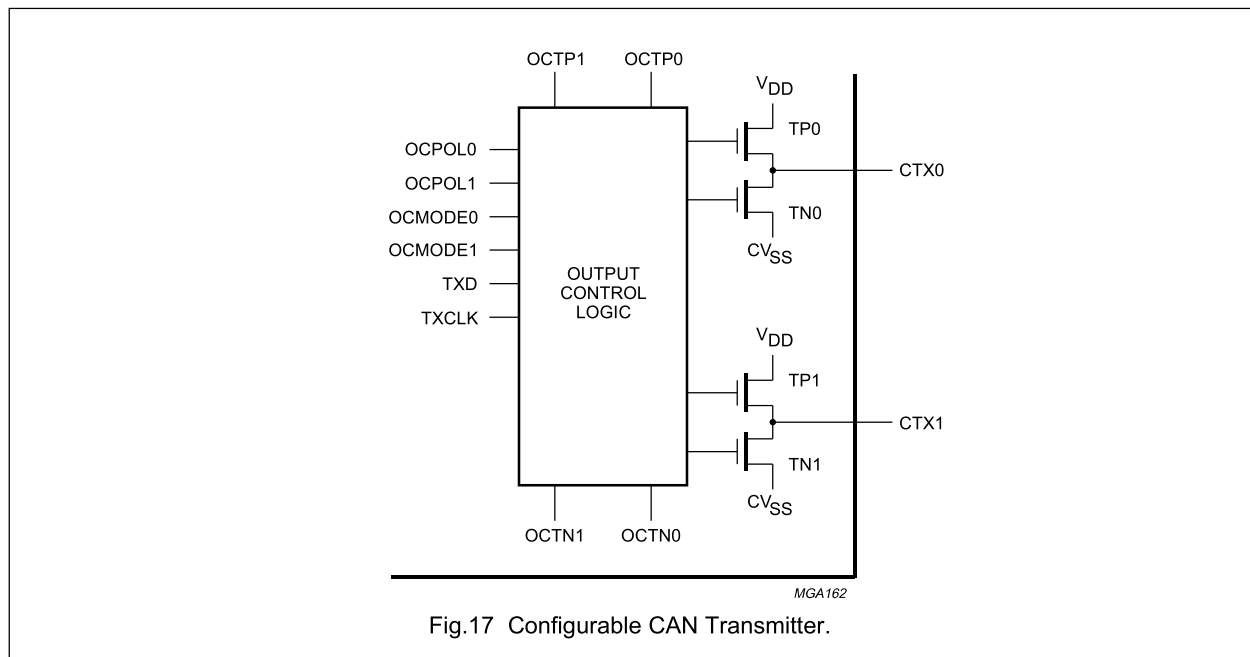

## 8-bit microcontroller with on-chip CAN

## P8xC592

## 13.5.12 TEST REGISTER (TR)

The Test Register is used for production testing only.

**Table 53** Test Register (address 9)

7	6	5	4	3	2	1	0
Reserved	Reserved	Map Internal Register	Connect RX Buffer 0 CPU	Connect TX Buffer CPU	Access Internal Bus	Normal RAM Connect	Float Output Driver

## 13.5.13 TRANSMIT BUFFER LAYOUT

The global layout of the Transmit Buffer is shown in Fig.15. This buffer serves to store a message from the CPU to be transmitted by the CAN-controller. It is subdivided into Descriptor and Data Field. The Transmit Buffer can be written to and read from by the CPU.

## 13.5.13.1 Descriptor

**Table 54** Descriptor Byte 1 Register (DSCR1, address 10)

7	6	5	4	3	2	1	0
ID.10	ID.9	ID.8	ID.7	ID.6	ID.5	ID.4	ID.3

**Table 55** Descriptor Byte 2 Register (DSCR2, address 11)

7	6	5	4	3	2	1	0
ID.2	ID.1	ID.0	RTR	DLC.3	DLC.2	DLC.1	DLC.0

**Table 56** Description of the ID.n bits in DSCR1 and DSCR2

BIT	SYMBOL	FUNCTION
<b>DSCR1</b>		
7	ID.10	<b>Identifier.</b> The Identifier consists of 11 bits (ID.10 to ID.0). ID.10 is the most significant bit, which is transmitted first on the bus during the arbitration process. The Identifier acts as the messages' name, used in a receiver for acceptance filtering, and also determines the bus access priority during the arbitration process. The lower the binary value of the Identifier the higher the priority. This is due to the larger number of leading dominant bits during arbitration (see Section 13.6.7).
6	ID.9	
5	ID.8	
4	ID.7	
3	ID.6	
2	ID.5	
1	ID.4	
0	ID.3	
<b>DSCR2</b>		
7	ID.2	<b>Identifier.</b> See DSCR1.
6	ID.1	
5	ID.0	

## 8-bit microcontroller with on-chip CAN

## P8xC592

**Table 57** Description of the other DSCR2 bits

BIT	SYMBOL	FUNCTION
4	RTR	<b>Remote Transmission Request.</b> If the RTR bit is: HIGH (remote), then the Remote Frame will be transmitted by the CAN-controller. LOW (data), then the Data Frame will be transmitted by the CAN-controller.
3	DLC.3	<b>Data Length Code (DLC).</b> The number of bytes (Data Byte Count) in the Data Field of a message is coded by the Data Length Code. At the start of a Remote Frame transmission the Data Length Code is not considered due to the RTR bit being HIGH (remote). This forces the number of transmitted/received data bytes to be a logic 0. Nevertheless, the Data Length Code must be specified correctly to avoid bus errors, if two CAN-controllers start a Remote Frame transmission simultaneously. The range of the Data Byte Count is 0 to 8 bytes and coded as follows: Data Byte Count = 8DLC.3 + 4DLC.2 + 2DLC.1 + DLC.0. For reasons of compatibility no Data Byte Counts other than 0,1,2,...8 should be used.
2	DLC.2	
1	DLC.1	
0	DLC.0	

**13.5.13.2 Data Field**

The number of transferred data bytes is determined by the Data Length Code. The first bit transmitted is the most significant bit of data byte 1 at address 12.

**13.5.14 RECEIVE BUFFER LAYOUT**

The layout of the Receive Buffer and the individual bytes correspond to the definitions given for the Transmit Buffer layout, except that the addresses start at 20 instead of 10 (see Fig.15).

**13.5.15 HANDLING OF THE CPU-CAN INTERFACE**

Via the four special registers CANADR, CANDAT, CANCON and CANSTA the CPU has access to the CAN-controller and also to the DMA-logic. Note that CANCON and CANSTA have different meanings for a Read and Write access.

**Table 58** The SFRs between CPU and CAN

Reserved bits are read as HIGH. R = Read; W = Write; R/W = Read/Write.

ADDRESS	ACCESS	BIT							
		7	6	5	4	3	2	1	0
<b>CANADR</b>									
DBH	R/W	DMA	Reserved	AutoInc	CANA4	CANA3	CANA2	CANA1	CANA0
<b>CANDAT</b>									
DAH	R/W	CAND7	CAND6	CAND5	CAND4	CAND3	CAND2	CAND1	CAND0
<b>CANCON; Do not use a RMW instruction</b>									
D9H	R	Reserved	Reserved	Reserved	WUI	OI	EI	TI	RI
	W	RX0A	RX1A	WUM	SLP	COS	RRB	AT	TR
<b>CANSTA; The bit addresses of CANSTA (7 to 0) are DFH to D8H; do not use a RMW instruction</b>									
DFH to D8H	R	BS	ES	TS	RS	TCS	TBS	DO	RBS
	W	RAMA7	RAMA6	RAMA5	RAMA4	RAMA3	RAMA2	RAMA1	RAMA0

## 8-bit microcontroller with on-chip CAN

P8xC592

## 13.5.15.1 Special Function Register CANADR

CANADR is implemented as a read/write register.

**Table 59** SFR CANADR (address DBH)

7	6	5	4	3	2	1	0
DMA	–	AutoInc	CANA4	CANA3	CANA2	CANA1	CANA0

**Table 60** Description of the CANADR bits

BIT	SYMBOL	FUNCTION
7	DMA	DMA-logic controlled via bit CANADR.7 (see Section 13.5.17).
6	–	Reserved.
5	AutoInc	Auto Address Increment mode controlled via bit CANADR.5 (see Section 13.5.16).
4	CANA4	The five least significant bits CANADR.4 to CANADR.0 define the address of one of the CAN-controller internal registers to be accessed via CANDAT. For instance, after an external hardware (e.g. power-on) reset CANADR contains the value 64H, and hence the CPU accesses (read/write) the Acceptance Code register of the CAN-controller, via the SFR CANDAT.
3	CANA3	
2	CANA2	
1	CANA1	
0	CANA0	

## 13.5.15.2 Special Function Register CANDAT

CANDAT is implemented as a read/write register.

**Table 61** SFR CANDAT (address DAH)

7	6	5	4	3	2	1	0
CAND7	CAND6	CAND5	CAND4	CAND3	CAND2	CAND1	CAND0

**Table 62** Description of the CANADR bits

BIT	SYMBOL	FUNCTION
7 to 0	CAND7 to CAND0	The SFR CANDAT appears as a port to the CAN-controller internal register (memory location) being selected by CANADR. Reading or writing CANDAT is effectively an access to that CAN-controller internal register, which is selected by CANADR.

## 8-bit microcontroller with on-chip CAN

P8xC592

## 13.5.15.3 Special Function Register CANCON

**Table 63** SFR CANCON in **Read** access (address D9H)

<b>7</b>	<b>6</b>	<b>5</b>	<b>4</b>	<b>3</b>	<b>2</b>	<b>1</b>	<b>0</b>
–	–	–	WUI	OI	EI	TI	RI

**Table 64** Description of the CANCON bits in **Read** access

When reading CANCON the Interrupt Register of the CAN-controller is accessed.

<b>BIT</b>	<b>SYMBOL</b>	<b>FUNCTION</b>
7	–	Reserved; bits are read as HIGH.
6	–	
5	–	
4	WUI	Wake-Up Interrupt (see Table 39).
3	OI	Overrun Interrupt (see Table 39).
2	EI	Error Interrupt (see Table 39).
1	TI	Transmit Interrupt (see Table 39).
0	RI	Receive Interrupt (see Table 39).

**Table 65** SFR CANCON in **Write** access (address D9H)

<b>7</b>	<b>6</b>	<b>5</b>	<b>4</b>	<b>3</b>	<b>2</b>	<b>1</b>	<b>0</b>
RX0A	RX1A	WUM	SLP	COS	RRB	AT	TR

**Table 66** Description of the CANCON bits in **Write** access

When writing to CANCON then the Command Register of the CAN-controller is accessed.

<b>BIT</b>	<b>SYMBOL</b>	<b>FUNCTION</b>
7	RX0A	RX0 Active (see Table 34).
6	RX1A	RX1 Active (see Table 34).
5	WUM	Wake-Up Mode (see Table 34).
4	SLP	Sleep (see Table 34).
3	COS	Clear Overrun Status (see Table 34).
2	RRB	Release Receive Buffer (see Table 34).
1	AT	Abort Transmission (see Table 34).
0	TR	Transmission Request (see Table 34).



## 8-bit microcontroller with on-chip CAN

P8xC592

## 13.5.15.4 Special Function Register CANSTA

CANSTA is implemented as a bit-addressable read/write register.  
The bit addresses of CANSTA (7 to 0) are DFH to D8H.

**Table 67** SFR CANCON in **Read** access (address DFH to D8H)

7	6	5	4	3	2	1	0
BS	ES	TS	RS	TCS	TBS	DO	RBS

**Table 68** Description of the CANCON bits in **Read** access

When reading CANSTA the Status Register of the CAN-controller is accessed.

BIT	SYMBOL	FUNCTION
7	BS	Bus Status (see Table 37).
6	ES	Error Status (see Table 37).
5	TS	Transmit Status (see Table 37).
4	RS	Receive Status (see Table 37).
3	TCS	Transmission Complete Status (see Table 37).
2	TBS	Transmit Buffer Access (see Table 37).
1	DO	Data Overrun (see Table 37).
0	RBS	Receive Buffer Status (see Table 37).

**Table 69** SFR CANCON in **Write** access (address DFH to D8H)

7	6	5	4	3	2	1	0
RAMA7	RAMA6	RAMA5	RAMA4	RAMA3	RAMA2	RAMA1	RAMA0

**Table 70** Description of the CANSTA bits in **Write** access

Writing to CANSTA sets the address of the on-chip MAIN RAM (internal Data Memory) for a subsequent DMA transfer.

BIT	SYMBOL	FUNCTION
7 to 0	RAMA7 to RAMA0	–

## 8-bit microcontroller with on-chip CAN

## P8xC592

### 13.5.16 AUTO ADDRESS INCREMENT

With the Auto Address Increment mode a fast stack-like reading and writing of CAN-controller internal registers is provided. If the bit CANADR.5 (AutoInc) is HIGH, the content of CANADR is incremented automatically after any read or write access to CANDAT. For instance, loading a message into the Transmit Buffer can be done by writing 2AH into CANADR and then moving byte by byte of the message to CANDAT. Incrementing CANADR beyond XX111111B resets the bit CANADR.5 (AutoInc) automatically (CANADR = XX000000B).

### 13.5.17 HIGH SPEED DMA

The DMA-logic allows you to transfer a complete message (up to 10 bytes) between CAN-controller and MAIN RAM in 2 instruction cycles at maximum; up to 4 bytes are transferred in 1 instruction cycle. The performance of the CPU is strongly enhanced because this very fast transfer is carried out in the background.

A DMA transfer is achieved by first writing the RAM address (00H to FFH) into CANSTA and then setting the TX- or RX-Buffer address in CANDR and the bit CANADR.7 (DMA) simultaneously; the RAM address points to the location of the first byte to be transferred. Setting the DMA bit causes an automatic evaluation of the Data Length Code and then the transfer; for a TX-DMA transfer the Data Length Code is expected at the location 'RAM address +1'.

In order to program a TX-DMA transfer the value 8AH (address 10) has to be written into CANADR. Then a complete message, consisting of the 2-byte Descriptor and the Data Field (0 to 8 bytes), starting at location 'RAM address' is transferred to the TX-Buffer.

The RX-DMA transfer is very versatile. By writing a value in the range of 94H (address 20) up to 9DH (address 29) into CANADR the whole or a part of the received message, starting at the specified address, is transferred to the internal Data Memory. This allows e.g. to transfer the bytes of the Data Field only.

After a successful DMA transfer the DMA-bit is reset.

During a DMA transfer the CPU can process the next instruction. However, an access to the Data Memory,

CANADR, CANDAT, CANCON or CANSTA is not allowed. After having set the DMA-bit, every interrupt is disabled until the end of the transfer. Note, that disadvantageous programming may lead to an interrupt response time of at most 10 instruction cycles. The shortest interrupt response time is achieved by using 2 consecutive 1-cycle instructions directly after setting the DMA-bit.

During the reset state (bit Reset Request is HIGH) a DMA transfer is not possible.

### 13.5.18 BUS TIMING/SYNCHRONIZATION

The Bus Timing Logic (BTL) monitors the serial bus-line via the on-chip input comparator and performs the following functions (see Section 13.4):

- Monitors the serial bus-line level
- Adjusts the sample point, within a bit period (programmable)
- Samples the bus-line level using majority logic (programmable, 1 or 3 samples)
- Synchronization to the bit stream:
  - hard synchronization at the start of a message
  - resynchronization during transfer of a message.

The configuration of the BTL is performed during the initialization of the CAN-controller. The BTL uses the following three registers:

- Control Register (Sync)
- Bus Timing Register 0
- Bus Timing Register 1.

### 13.5.19 BIT TIMING

A bit period is built up from a number of system clock cycles ( $t_{SCL}$ ), see Section 13.5.9.

One bit period is the result of the addition of the programmable segments TSEG1 and TSEG2 and the general segment SYNCSEG.

#### 13.5.19.1 Synchronization Segment (SYNCSEG)

The incoming edge of a bit is expected during this state; this state corresponds to one system clock cycle ( $1 \times t_{SCL}$ ).

## 8-bit microcontroller with on-chip CAN

## P8xC592

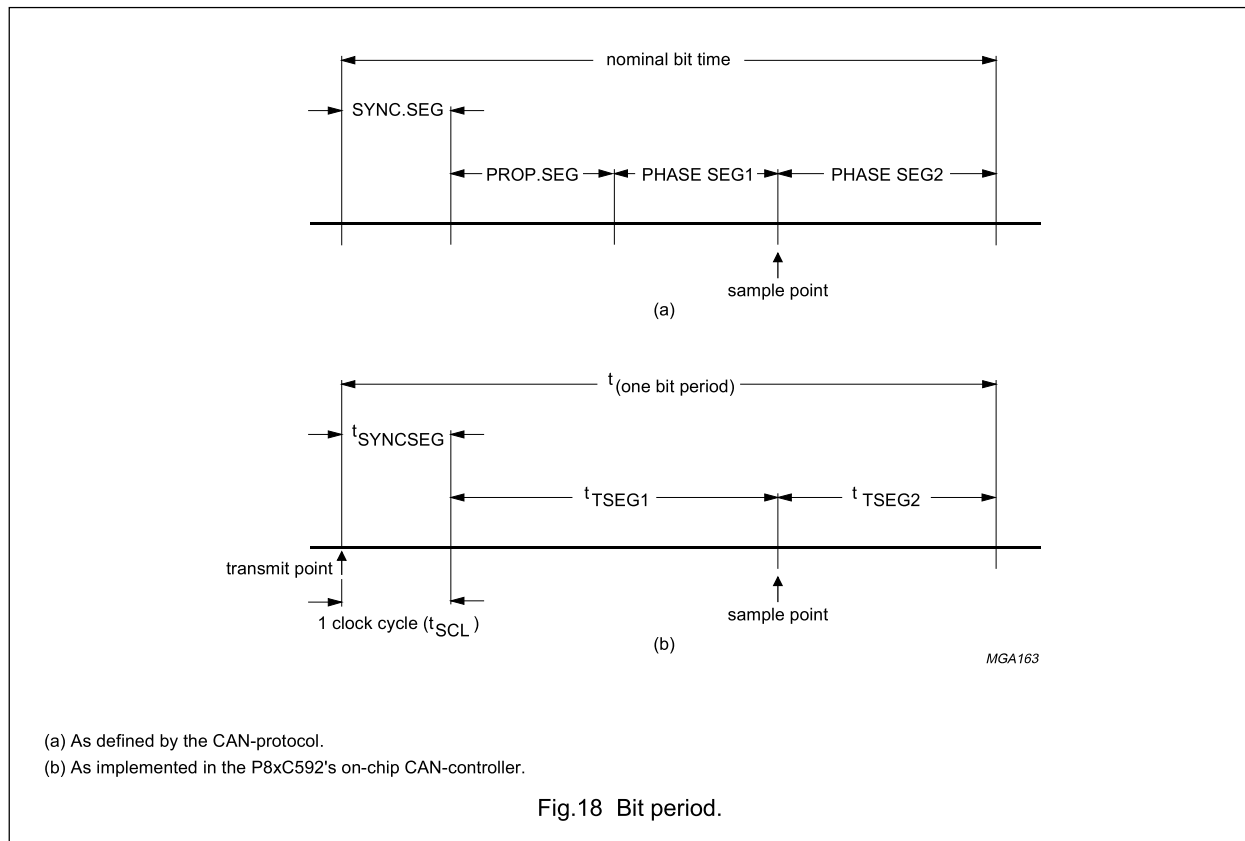

### 13.5.19.2 Time Segment 1 (TSEG1)

This segment determines the location of the sampling point within a bit period, which is at the end of TSEG1. TSEG1 is programmable from 1 to 16 system clock cycles (see Section 13.5.10).

The correct location of the sample point is essential for the correct functioning of a transmission. The following points must be taken into consideration:

- A Start-Of-Frame (see Section 13.6.2) causes all CAN-controllers to perform a 'hard synchronization' (see Section 13.5.20) on the first recessive-to-dominant edge. During arbitration, however, several CAN-controllers may simultaneously transmit. Therefore it may require twice the sum of bus-line, input comparator and the output driver delay times until the bus is stable. This is the propagation delay time.

- To avoid sampling at an incorrect position, it is necessary to include an additional synchronization buffer on both sides of the sample point. The main reasons for incorrect sampling are:
  - Incorrect synchronization due to spikes on the bus-line
  - Slight variations in the oscillator frequency of each CAN-controller in the network, which results in a phase error.
- Time Segment 1 consists of the segment for compensation of propagation delays and the synchronization buffer segment directly before the sample point (see Fig.18).

## 8-bit microcontroller with on-chip CAN

## P8xC592

### 13.5.19.3 Time Segment 2 (TSEG2)

This time segment provides:

- Additional time at the sample point for calculation of the subsequent bit levels (e.g. arbitration)
- Synchronization buffer segment directly after the sample point.

TSEG2 is programmable from 1 to 8 system clock cycles (see Section 13.5.10).

### 13.5.19.4 Synchronisation Jump Width (SJW)

SJW defines the maximum number of clock cycles ( $t_{SCL}$ ) a period may be reduced or increased by one resynchronization. SJW is programmable from 1 to 4 system clock cycles, see Section 13.5.2.

### 13.5.19.5 Propagation Delay Time ( $t_{prop}$ )

The Propagation Delay Time is:

$$t_{prop} = 2 \times (\text{physical bus delay} \\ + \text{input comparator delay} \\ + \text{output driver delay}).$$

$t_{prop}$  is rounded up to the nearest multiple of  $t_{SCL}$ .

### 13.5.19.6 Bit Timing Restrictions

Restrictions on the configuration of the bit timing are based on internal processing. The restrictions are:

- $t_{TSEG2} \geq 2t_{SCL}$
- $t_{TSEG2} \geq t_{SJW}$
- $t_{TSEG1} \geq t_{TSEG2}$
- $t_{TSEG1} \geq t_{SJW} + t_{prop}$ .

The three sample mode (SAM = HIGH) has the effect of introducing a delay of one system clock cycle on the bus-line. This must be taken into account for the correct calculation of TSEG1 and TSEG2:

- $t_{TSEG1} \geq t_{SJW} + t_{prop} + 2t_{SCL}$
- $t_{TSEG2} \geq 3t_{SCL}$ .

### 13.5.20 SYNCHRONIZATION

Synchronization is performed by a state machine which compares the incoming edge with its actual bit timing and adapts the bit timing by hard synchronization or resynchronization.

This type of synchronization occurs only at the beginning of a message.

The CAN-controller synchronizes on the first incoming recessive-to-dominant edge of a message (being the leading edge of a message's Start-Of-Frame bit; see Section 13.6.2.

Resynchronization occurs during the transmission of a message's bit stream to compensate for:

- Variations in individual CAN-controller oscillator frequencies
- Changes introduced by switching from one transmitter to another (e.g. during arbitration).

As a result of resynchronization either  $t_{TSEG1}$  may be increased by up to a maximum of  $t_{SJW}$  or  $t_{TSEG2}$  may be decreased by up to a maximum of  $t_{SJW}$ :

- $t_{TSEG1} \leq t_{SCL} [(TSEG1 + 1) + (SJW + 1)]$
- $t_{TSEG2} \geq t_{SCL} [(TSEG2 + 1) - (SJW + 1)]$ .

TSEG1, TSEG2 and SJW are the programmed numerical values.

The phase error ( $e$ ) of an edge is given by the position of the edge relative to SYNCSEG, measured in system clock cycles ( $t_{SCL}$ ).

The value of the phase error is defined as:

- $e = 0$ , if the edge occurs within SYNCSEG
- $e > 0$ , if the edge occurs within TSEG1
- $e < 0$ , if the edge occurs within TSEG2.

The effect of resynchronization is:

- The same as that of a hard synchronization, if the magnitude of the phase error ( $e$ ) is less or equal to the programmed value of  $t_{SJW}$
- To increase a bit period by the amount of  $t_{SJW}$ , if the phase error is positive and the magnitude of the phase error is larger than  $t_{SJW}$
- To decrease a bit period by the amount of  $t_{SJW}$ , if the phase error is negative and the magnitude of the phase error is larger than  $t_{SJW}$ .

## 8-bit microcontroller with on-chip CAN

## P8xC592

### 13.5.20.1 Synchronization Rules

The synchronization rules are as follows:

- Only one synchronization within one bit time is used.
- An edge is used for synchronization only if the value detected at the previous sample point differs from the bus value immediately after the edge.
- Hard synchronization is performed whenever there is a recessive-to-dominant edge during Bus-Idle (see Section 13.6.6).
- All other edges (recessive-to-dominant and optionally dominant-to recessive edges if the Sync bit is set HIGH (see Section 13.5.3) which are candidates for resynchronization will be used with the following exception:
  - A transmitting CAN-controller will not perform a resynchronization as a result of a recessive-to-dominant edge with positive phase error, if only these edges are used for resynchronization. This ensures that the delay times of the output driver and input comparator do not cause a permanent increase in the bit time.

## 13.6 CAN 2.0A Protocol description

### 13.6.1 FRAME TYPES

The P8xC592's CAN-controller supports the four different CAN-protocol frame types for communication:

- Data Frame, to transfer data
- Remote Frame, request for data
- Error Frame, globally signal a (locally) detected error condition
- Overload Frame, to extend delay time of subsequent frames (an Overload Frame is not initiated by the P8xC592 CAN-controller).

#### 13.6.1.1 Bit representation

There are two logical bit representations used in the CAN-protocol:

- A recessive bit on the bus-line appears only if all connected CAN-controllers send a recessive bit at that moment.
- Dominant bits always overwrite recessive bits i.e. the resulting bit level on the bus-line is dominant.

### 13.6.2 DATA FRAME

A Data Frame carries data from a transmitting CAN-controller to one or more receiving ones.

A Data Frame is composed of seven different bit-fields:

- Start-Of-Frame
- Arbitration Field
- Control Field
- Data Field (may have a length of zero)
- CRC Field (CRC = Cyclic Redundancy Code)
- Acknowledge Field
- End-Of-Frame.

#### 13.6.2.1 Start-Of-Frame bit

Signals the start of a Data Frame or Remote Frame. It consists of a single dominant bit use for hard synchronization of a CAN-controller in receive mode.

#### 13.6.2.2 Arbitration Field

Consists of the message Identifier and the RTR bit. In the case of simultaneous message transmissions by two or more CAN-controllers the bus access conflict is solved by bit-wise arbitration, which is active during the transmission of the Arbitration Field.

#### 13.6.2.3 Identifier

This 11-bit field is used to provide information about the message, as well as the bus access priority. It is transmitted in the order ID.10 to ID.0 (LSB). The situation that the seven most significant bits (ID.10 to ID.4) are all recessive must not occur.

An Identifier does not define which particular CAN-controller will receive the frame because a CAN based communication network does not differentiate between a point-to-point, multicast or broadcast communication.

---

## 8-bit microcontroller with on-chip CAN

## P8xC592

---

### 13.6.2.4 RTR bit

A CAN-controller, acting as a receiver for certain information may initiate the transmission of the respective data by transmitting a Remote Frame to the network, addressing the data source via the Identifier and setting the RTR bit HIGH (remote; recessive bus level). If the data source simultaneously transmits a Data Frame containing the requested data, it uses the same Identifier. No bus access conflict occurs due to the RTR bit being set LOW (data; dominant bus level) in the Data Frame.

### 13.6.2.5 Control Field

This field consists of six bits. It includes two reserved bits (for future expansions of the CAN-protocol), transmitted with a dominant bus level, and is followed by the Data Length Code (4 bits).

The number of bytes (destuffed; number of data bytes to be transmitted/received) in the Data Field is indicated by the Data Length Code. Admissible values of the Data Length Code, and hence the number of bytes in the (destuffed) Data Field, are {0, 1, ..., 8}. A logic 0 (logic 1) in the Data Length Code is transmitted as dominant (recessive) bus level, respectively.

### 13.6.2.6 Data Field

The data, stored within the Data Field of the Transmit Buffer, are transmitted according to the Data Length Code. Conversely, data of a received Data Frame will be stored in the Data Field of a Receive Buffer. The Data Field can contain from 0 up to 8 bytes. The most significant bit of the first data byte (lowest address) is transmitted/received first.

### 13.6.2.7 Cyclic Redundancy Code Field (CRC)

The CRC Field consists of the CRC Sequence (15 bits) and the CRC Delimiter (1 recessive bit). The Cyclic Redundancy Code (CRC) encloses the destuffed bit stream of the Start-Of-Frame, Arbitration Field, Data Field and CRC Sequence. The most significant bit of the CRC Sequence is transmitted/received first. This frame check sequence, implemented in the CAN-controller is derived from a cyclic redundancy code best suited for frames with a total bit count of less than 127 bits, see Section 13.6.8.3. With Start-Of-Frame (dominant bit) included in the code word, any rotation of the code word can be detected by the absence of the CRC Delimiter (recessive bit).

### 13.6.2.8 Acknowledge Field (ACK)

The Acknowledge Field consists of two bits, the Acknowledge Slot and the Acknowledge Delimiter, which are transmitted with a recessive level by the transmitter of the Data Frame. All CAN-controllers having received the matching CRC Sequence, report this by overwriting the transmitter's recessive bit in the Acknowledge Slot with a dominant bit. Thereby a transmitter, still monitoring the bus level recognizes that at least one receiver within the network has received a complete and correct message (i.e. no error was found). The Acknowledge Delimiter (recessive bit) is the second bit of the Acknowledge Field. As a result, the Acknowledge Slot is surrounded by two recessive bits: the CRC Delimiter and the Acknowledge Delimiter.

All nodes within a CAN network may use all the information coming to the network by all CAN-controllers (shared memory concept). Therefore, acknowledgement and error handling are defined to provide all information in a consistent way throughout this shared memory. Hence, there is no reason to discriminate different receivers of a message in the acknowledge field. If a node is disconnected from the network due to bus failure, this particular node is no longer part of the shared memory. To identify a 'lost node' additional and application specific precautions are required.

### 13.6.2.9 End-Of-Frame

Each Data Frame or Remote Frame is delimited by the End-Of-Frame bit sequence which consists of seven recessive bits (exceeds the bit stuff width by two bits). Using this method a receiver detects the end of a frame independent of a previous transmission error because the receiver expects all bits up to the end of the CRC Sequence to be coded by the method of bit-stuffing, see Section 13.6.7.3. The bit-stuffing logic is deactivated during the End-Of-Frame sequence.

8-bit microcontroller with on-chip CAN

P8xC592

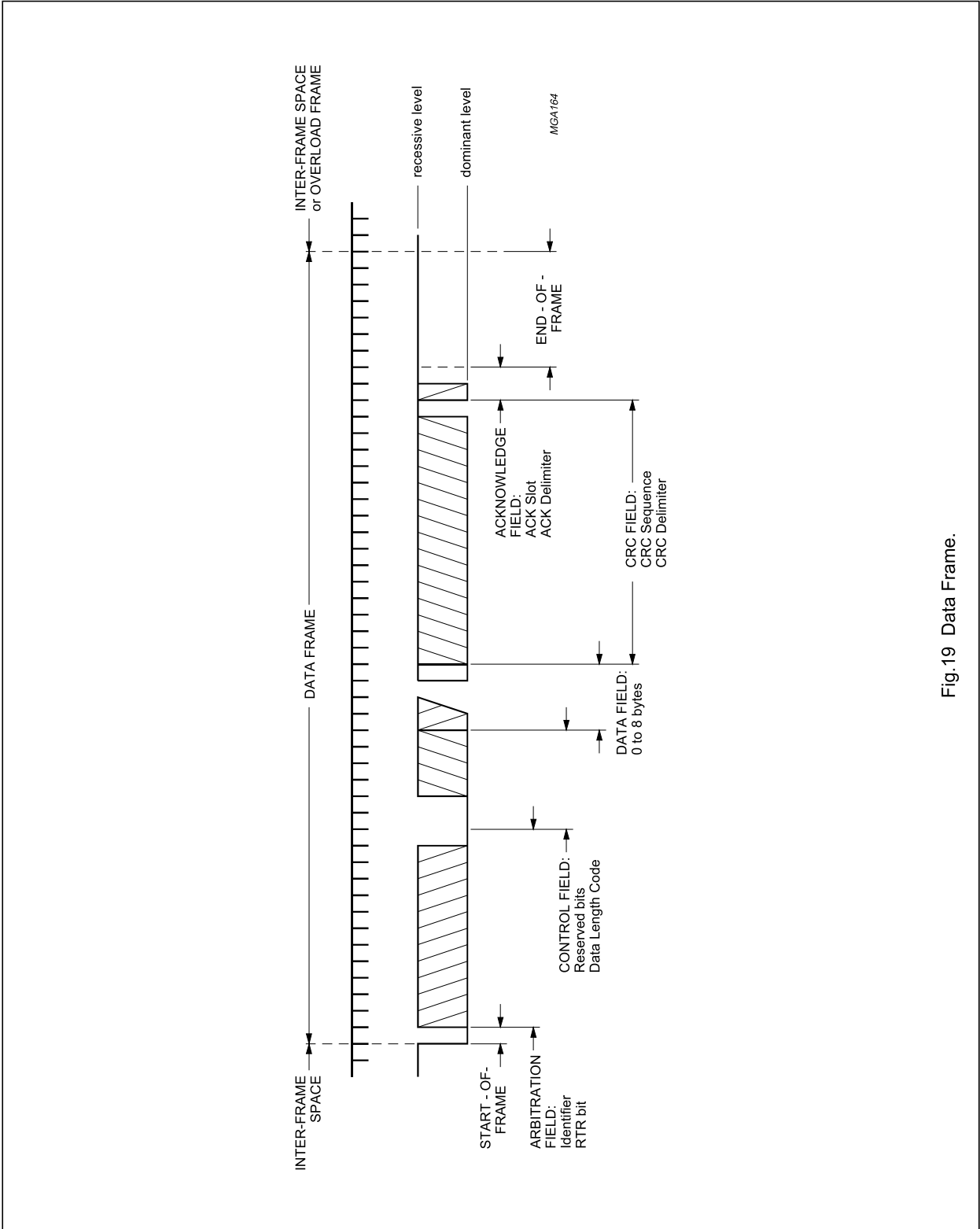

Fig. 19 Data Frame.

## 8-bit microcontroller with on-chip CAN

## P8xC592

### 13.6.3 REMOTE FRAME

A CAN-controller acting as a receiver for certain information may initiate the transmission of the respective data by transmitting a Remote Frame to the network, addressing the data source via the Identifier and setting the RTR bit HIGH (remote; recessive bus level). The Remote Frame is similar to the Data Frame with the following exceptions:

- RTR bit is set HIGH
- Data Length Code is ignored
- No Data Field contained.

Note that the value of the Data Length Code should be the one of the corresponding Data Frame, although it is ignored for a Remote Frame.

A Remote Frame is composed of six different bit fields:

- Start-of-Frame
- Arbitration Field
- Control Field
- CRC Field
- Acknowledge Field
- End-Of-Frame.

See Section 13.6.2 for more detailed explanation of the Remote Frame bit fields.

### 13.6.4 ERROR FRAME

The Error Frame consists of two different fields:

- The first field, accomplished by the superimposing of Error Flags contributed from different CAN-controllers
- The second field is the Error Delimiter.

#### 13.6.4.1 Error Flag

There are two forms of an Error Flag:

- Active Error Flag, consists of six consecutive dominant bits.
- Passive Error Flag, consists of six consecutive recessive bits unless it is overwritten by dominant bits from other CAN-controllers.

An error-active CAN-controller (see Section 13.6.9) detecting an error condition signals this by transmission of an Active Error Flag. This Error Flag's form violates the bit-stuffing rule (see Section 13.6.7) applied to all fields,

from Start-Of-Frame to CRC Delimiter, or destroys the fixed form of the fields Acknowledge Field or End-Of-Frame (see Fig.20).

Consequently, all other CAN-controllers detect an error condition and start transmission of an Error Flag. Therefore the sequence of dominant bits, which can be monitored on the bus, results from a superposition of different Error Flags transmitted by individual CAN-controllers. The total length of this sequence varies between six (minimum) and twelve (maximum) bits.

An error-passive CAN-controller (see Section 13.6.9) detecting an error condition tries to signal this by transmission of a Passive Error Flag. The error-passive CAN-controller waits for six consecutive bits with identical polarity, beginning at the start of the Passive Error Flag. The Passive Error Flag is complete when these six identical bits have been detected.

#### 13.6.4.2 Error Delimiter

The Error Delimiter consists of eight recessive bits and has the same format as the Overload Delimiter. After transmission of an Error Flag, each CAN-controller monitors the bus-line until it detects a transition from a dominant-to-recessive bit level. At this point in time, every CAN-controller has finished sending its Error Flag and has additionally sent the first out of the 8 recessive bits of the Error Delimiter. Afterwards all CAN-controllers transmit the remaining recessive bits. After this event and an Intermission Field all error-active CAN-controllers within the network can start a transmission simultaneously.

If a detected error is signalled during transmission of a Data Frame or Remote Frame, the current message is spoiled and a retransmission of the message is initiated.

If a CAN-controller monitors any deviation of the Error Frame, a new Error Frame will be transmitted. Several consecutive Error Frames may result in the CAN-controller becoming error-passive and leaving the network unblocked.

In order to terminate an Error Flag correctly, an error-passive CAN-controller requires the bus to be Bus-Idle (see Section 13.6.6) for at least three bit periods (if there is a local error at an error-passive-receiver). Therefore a CAN-bus should not be 100% permanently loaded.



## 8-bit microcontroller with on-chip CAN

## P8xC592

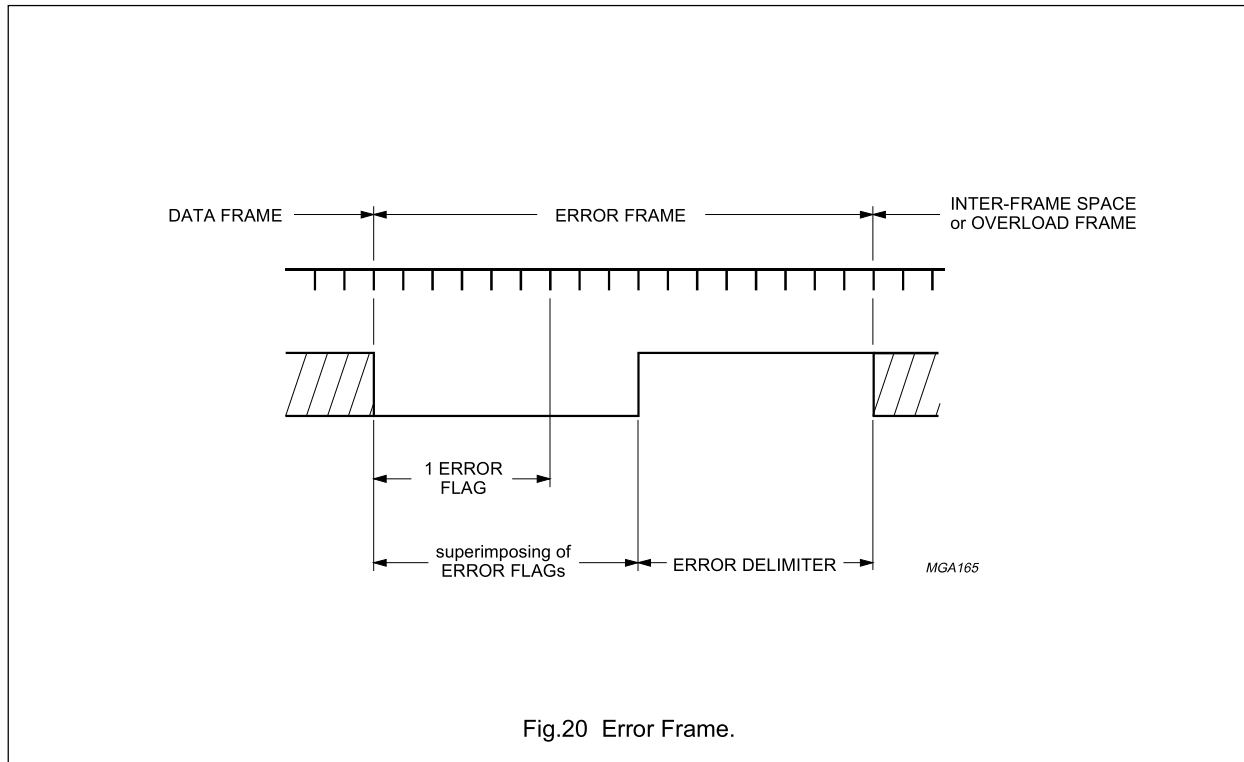

Fig.20 Error Frame.

## 13.6.5 OVERLOAD FRAME

The Overload Frame consists of two fields:

- The Overload Flag
- The Overload Delimiter.

The transmission of an Overload Frame may only start:

- Condition 1; during the first bit period of an expected Intermission Field.
- Condition 2; one bit period after detecting the dominant bit during Intermission Field.

The P8xC592's on-chip CAN-controller will never initiate transmission of a condition 1 Overload Frame and will only react on a transmitted condition 2 Overload Frame, according to the CAN-protocol. No more than two Overload Frames are generated to delay a Data Frame or a Remote Frame. Although the overall form of the Overload Frame corresponds to that of the Error Frame, an Overload Frame does not initiate or require the retransmission of the preceding frame.

## 13.6.5.1 Overload Flag

The Overload Flag consists of six dominant bits and has a similar format to the Error Flag.

There are two conditions in the CAN-protocol which lead to the transmission of an Overload Flag:

- Condition 1; receiver circuitry requires more time to process the current data before receiving the next frame (receiver not ready).
- Condition 2; detection of a dominant bit during Intermission Field (see Section 13.6.6).

The Overload Flag's form corrupts the fixed form of the Intermission Field. All other CAN-controllers detecting the overload condition also transmit an Overload Flag (condition 2).

## 8-bit microcontroller with on-chip CAN

## P8xC592

### 13.6.5.2 Overload Delimiter

The Overload Delimiter consists of eight recessive bits and takes the same form as the Error Delimiter. After transmission of an Overload Flag, each CAN-controller monitors the bus-line until it detects a transition from a dominant-to-recessive bit level. At this point in time, every CAN-controller has finished sending its Overload Flag and all CAN-controllers start simultaneously transmitting seven more recessive bits.

### 13.6.6 INTER-FRAME SPACE

Data Frames and Remote Frames are separated from preceding frames (all types) by an Inter-Frame Space, consisting of an Intermission Field and a Bus-Idle. Error-passive CAN-controllers also send a Suspend Transmission (see Section 13.6.9) after transmission of a message. Overload Frames and Error Frames are not preceded by an Inter-Frame Space.

#### 13.6.6.1 Intermission Field

The Intermission Field consists of three recessive bits. During an Intermission period, no frame transmissions will be started by the P8xC592's on-chip CAN-controller. An Intermission is required to have a fixed time period to allow a CAN-controller to execute internal processes prior to the next receive or transmit task.

#### 13.6.6.2 Bus-Idle

The Bus-Idle time may be of arbitrary length (min. 0 bit). The bus is recognized to be free and a CAN-controller having information to transmit may access the bus. The detection of a dominant bit level during Bus-Idle on the bus is interpreted as the Start-Of-Frame.

### 13.6.7 BUS ORGANIZATION

Bus organization is based on five basic rules described in the following subsections.

#### 13.6.7.1 Bus Access

CAN-controllers only start transmission during the Bus-Idle state. All CAN-controllers synchronize on the leading edge of the Start-Of-Frame (hard synchronization).

#### 13.6.7.2 Bus Arbitration

If two or more CAN-controllers simultaneously start transmitting, the bus access conflict is solved by a bit-wise arbitration process during transmission of the Arbitration Field.

During arbitration every transmitting CAN-controller compares its transmitted bit level with the monitored bus level. Any CAN-controller which transmits a recessive bit and monitors a dominant bus level immediately becomes the receiver of the higher-priority message on the bus without corrupting any information on the bus. Each message contains an unique Identifier and a RTR bit describing the type of data within the message. The Identifier together with the RTR bit implicitly define the message's bus access priority. During arbitration the most significant bit of the Identifier is transmitted first and the RTR bit last. The message with the lowest binary value of the Identifier and RTR bit has the highest priority. A Data Frame has higher priority than a Remote Frame due to its RTR bit having a dominant level.

For every Data Frame there is an unique transmitter. For reasons of compatibility with other CAN-bus controllers, use of the Identifier bit pattern ID = 1111111XXXXB (X being bits of arbitrary level) is forbidden.

The number of available different Identifiers:

$$(2^{11} - 2^4) = 2032.$$

#### 13.6.7.3 Coding/Decoding

The following bit fields are coded using the bit-stuffing technique:

- Start-Of-Frame
- Arbitration Field
- Control Field
- Data Field
- CRC Sequence.

When a transmitting CAN-controller detects five consecutive bits of identical polarity to be transmitted, a complementary (stuff) bit is inserted into the transmitted bit-stream.

When a receiving CAN-controller has monitored five consecutive bits with identical polarity in the received bit streams of the above described bit fields, it automatically deletes the next received (stuff) bit. The level of the deleted stuff bit has to be the complement of the previous bits; otherwise a Stuff Error will be detected and signalled (see Section 13.6.8).

The remaining bit fields or frames are of fixed form and are not coded or decoded by the method of bit-stuffing.

The bit-stream in a message is coded according to the Non-Return-to-Zero (NRZ) method, i.e. during a bit period, the bit level is held constant, either recessive or dominant.

## 8-bit microcontroller with on-chip CAN

## P8xC592

### 13.6.7.4 Error Signalling

A CAN-controller which detects an error condition, transmits an Error Flag. Whenever a Bit Error, Stuff Error, Form Error or an Acknowledgement Error is detected, transmission of an Error Flag is started at the next bit. Whenever a CRC Error is detected, transmission of an Error Flag starts at the bit following the Acknowledge Delimiter, unless an Error Flag for another error condition has already started. An Error Flag violates the bit-stuffing law or corrupts the fixed form bit fields. A violation of the bit-stuffing law affects any CAN-controller which detects the error condition. These devices will also transmit an Error Flag.

An error-passive CAN-controller (see Section 13.6.9) which detects an error condition, transmits a Passive Error Flag. A Passive Error Flag is not able to interrupt a current message at different CAN-controllers but this type of Error Flag may be ignored (overwritten) by other CAN-controllers. After having detected an error condition, an error-passive CAN-controller will wait for six consecutive bits with identical polarity and when monitoring them, interpret them as an Error Flag.

After transmission of an Error Flag, each CAN-controller monitors the bus-line until it detects a transition from a dominant-to-recessive bit level. At this point in time, every CAN-controller has finished transmitting its Error Flag and all CAN-controllers start transmitting seven additional recessive bits (Error Delimiter, see Section 13.6.4).

The message format of a Data Frame or Remote Frame is defined in such a way that all detectable errors can be signalled within the message transmission time and therefore it is very simple for the CAN-controllers to associate an Error Frame to the corresponding message and to initiate retransmission of the corrupted message. If a CAN-controller monitors any deviation of the fixed form of an Error Frame, it transmits a new Error Frame.

### 13.6.7.5 Overload Signalling

Some CAN-controllers (but not the one on-chip of the P8xC592) require to delay the transmission of the next Data Frame or Remote Frame by transmitting one or more Overload Frames. The transmission of an Overload Frame must start during the first bit of an expected Intermission Field. Transmission of Overload Frames which are reactions on a dominant bit during an expected Intermission Field, start one bit after this event.

Though the format of Overload Frame and Error Frame are identical, they are treated differently. Transmission of an Overload Frame during Intermission Field does not initiate

the retransmission of any previous Data Frame or Remote Frame. If a CAN-controller which transmitted an Overload Frame monitors any deviation of its fixed form, it transmits an Error Frame.

### 13.6.8 ERROR DETECTION

The processes described in Sections 13.6.8.1 to 13.6.10.3 are implemented in the P8xC592's on-chip CAN-controller for error detection.

#### 13.6.8.1 Bit Error

A transmitting CAN-controller monitors the bus on a bit-by-bit basis. If the bit level monitored is different from the transmitted one, a Bit Error is signalled.

The exceptions being:

- During the Arbitration Field, a recessive bit can be overwritten by a dominant bit. In this case, the CAN-controller interprets this as a loss of arbitration.
- During the Acknowledge Slot, only the receiving CAN-controllers are able to recognize a Bit Error.

#### 13.6.8.2 Stuff Error

The following bit fields are coded using the bit-stuffing technique:

- Start-Of-Frame
- Arbitration Field
- Control Field
- Data Field
- CRC Sequence.

There are two possible ways of generating a Stuff Error:

- A disturbance generates more than the allowed five consecutive bits with identical polarity. These errors are detected by all CAN-controllers.
- A disturbance falsifies one or more of the five bits preceding the stuff bit. This error situation is not recognized as a Stuff Error by the receivers. Therefore, other error detection processes may detect this error condition such as:
  - CRC check, format violation at the receiving CAN-controllers, or
  - Bit Error detection by the transmitting CAN-controller.

## 8-bit microcontroller with on-chip CAN

## P8xC592

### 13.6.8.3 CRC Error

To ensure the validity of a transmitted message all receivers perform a CRC check. Therefore, in addition to the (destuffed) information digits (Start-Of-Frame up to Data Field), every message includes some control digits (CRC Sequence; generated by the transmitting CAN-controller of the respective message) used for error detection.

The code used by all CAN-controllers is a (shortened) BCH code, extended by a parity check and has the following attributes:

- 127 bits as maximum length of the code.
- 112 bits as maximum number of information digits (max. 83 bits are used by the CAN-controller).
- Length of the CRC Sequence amounts to 15 bits.
- Hamming distance  $d = 6$ .

As a result, '(d-1)' random errors are detectable (some exceptions exist).

The CRC Sequence is determined (calculated) by the following procedure:

1. The destuffed bit stream consisting of Start-Of-Frame up to the Data Field (if present) is interpreted as polynomial with coefficients 0 or 1.
2. This polynomial is divided (modulo-2) by the following generator polynomial, which includes a parity check:
 
$$f(x) = (x^{14} + x^9 + x^8 + x^6 + x^5 + x^4 + x^2 + x + 1)$$

$$(x + 1) = 1100010110011001 \text{ B.}$$
3. The remainder of this polynomial division is the CRC Sequence.

Burst errors are detected up to a length of 15 [degree of  $f(x)$ ]. Multiple errors (number of disturbed bits at least  $d = 6$ ) are not detected with a residual error probability of  $2^{-15}$  ( $3 \times 10^{-5}$ ) by CRC check only.

### 13.6.8.4 Form Error

Form Errors result from violations of the fixed form of the following bit fields:

- CRC Delimiter
- Acknowledge Delimiter
- End-Of-Frame
- Error Delimiter
- Overload Delimiter.

During the transmission of these bit fields an error condition is recognized if a dominant bit level instead of a recessive one is detected.

### 13.6.8.5 Acknowledgement Error

This is detected by a transmitter whenever it does not monitor a dominant bit during the Acknowledge Slot.

### 13.6.8.6 Error detection by an Error Flag from another CAN-controller

The detection of an error is signalled by transmitting an Error Flag. An Active Error Flag causes a Stuff Error, a Bit Error or a Form Error at all other CAN-controllers.

### 13.6.8.7 Error Detection Capabilities

Errors which occur at all CAN-controllers (global errors) are 100% detected. For local errors, i.e. for errors occurring at some CAN-controllers only, the shortened BCH code, extended by a parity check, has the following error detection capabilities:

- Up to five single Bit Errors are 100% detected, even if they are distributed randomly within the code.
- All single Bit Errors are detected if their total number (within the code) is odd.
- The residual error probability of the CRC check amounts to ( $3 \times 10^{-5}$ ). As an error may be detected not only by CRC check but also by other detection processes described above the residual error probability is several magnitudes less than ( $3 \times 10^{-5}$ ).

## 13.6.9 ERROR CONFINEMENT DEFINITIONS

### 13.6.9.1 Bus-OFF

A CAN-controller which has too many unsuccessful transmissions, relative to the number of successful transmissions, will enter the Bus-OFF state. It remains in this state, neither receiving nor transmitting messages until the Reset Request bit is set LOW (absent) and both Error Counters set to 0 (see Section 13.6.10).

### 13.6.9.2 Acknowledge

A CAN-controller which has received a valid message correctly, indicates this to the transmitter by transmitting a dominant bit level on the bus during the Acknowledge Slot, independent of accepting or rejecting the message.

### 13.6.9.3 Error-Active

An error-active CAN-controller in its normal operating state is able to receive and to transmit normally and also to transmit an Active Error Flag (see Section 13.6.10).

## 8-bit microcontroller with on-chip CAN

## P8xC592

### 13.6.9.4 Error-Passive

An error-passive CAN-controller may transmit or receive messages normally. In the case of a detected error condition it transmits a Passive Error Flag instead of an Active Error Flag. Hence the influence on bus activities by an error-active CAN-controller (e.g. due to a malfunction) is reduced.

### 13.6.9.5 Suspend Transmission

After an error-passive CAN-controller has transmitted a message, it sends eight recessive bits after the Intermission Field and then checks for Bus-Idle. If during Suspend Transmission another CAN-controller starts transmitting a message the suspended CAN-controller will become the receiver of this message; otherwise being in Bus-Idle it may start to transmit a further message.

### 13.6.9.6 Start-Up

A CAN-controller which either was switched off or in the Bus-OFF state, must run a Start-Up routine in order to:

- Synchronize with other available CAN-controllers before starting to transmit. Synchronization is achieved, when 11 recessive bits, equivalent to Acknowledge Delimiter, End-Of-Frame and Intermission Field, have been detected (Bus-Free).
- Wait for other CAN-controllers without passing into the Bus-OFF state (due to a missing acknowledge), if there is no other CAN-controller currently available.

## 13.6.10 AIMS OF ERROR CONFINEMENT

### 13.6.10.1 Distinction of short and long disturbances

The CPU must be informed when there are long disturbances and when bus activities have returned to normal operation. During long disturbances, a CAN-controller enters the Bus-OFF state and the CPU may use default values.

Minor disturbances of bus activities will not effect a CAN-controller. In particular, a CAN-controller does not enter the Bus-OFF state or inform the CPU of a short bus disturbance.

### 13.6.10.2 Detection and localization of hardware disturbances and defects

The rules for error confinement are defined by the CAN-protocol specification (and implemented in the P8xC592's on-chip CAN-controller), in such a way that the CAN-controller, being nearest to the error-locus, reacts with a high probability the quickest (i.e. becomes error-passive or Bus-OFF). Hence errors can be localized and their influence on normal bus activities is minimized.

### 13.6.10.3 Error Confinement

All CAN-controllers contain a Transmit Error Counter and a Receive Error Counter, which registers errors during the transmission and the reception of messages, respectively.

If a message is transmitted or received correctly, the count is decreased. In the event of an error, the count is increased. The Error Counters have a non-proportional method of counting: an error causes a larger counter increase than a correctly transmitted/received message causes the count to decrease. Over a period of time this may result in an increase in error counts, even if there are fewer corrupted messages than uncorrupted ones. The level of the Error Counters reflect the relative frequency of disturbances. The ratio of increase/decrease depends on the acceptable ratio of invalid/valid messages on the bus and is hardware implemented to eight.

If one of the Error Counters exceeds the Warning Limit of 96 error points, indicating a significant accumulation of error conditions, this is signalled by the CAN-controller (Error Status, Error Interrupt).

A CAN-controller operates in the error-active mode until it exceeds 127 error points on one of its Error Counters. At this value it will enter the error-passive state. A transmit error which exceeds 255 error points results in the CAN-controller entering the Bus-OFF state.

---

## 8-bit microcontroller with on-chip CAN

P8xC592

---

### 14 INTERRUPT SYSTEM

External events and the real-time-driven on-chip peripherals require service by the CPU asynchronous to the execution of any particular section of code. To tie the asynchronous activities of these functions to normal program execution a multiple-source, two-priority-level, nested interrupt system is provided. Interrupt response latency is from 2.25  $\mu$ s to 7.5  $\mu$ s when using a 16 MHz crystal. The latency time strongly depends on the sequence of instructions executed directly after an interrupt request. During a CAN-DMA transfer the interrupt system is disabled (see Section 13.5.17). The P8xC592 acknowledges interrupt requests from fifteen sources as follows:

- $\overline{\text{INT0}}$  and  $\overline{\text{INT1}}$ : externally via pins 27 and 28 respectively
- Timer 0 and Timer 1: from the two internal counters
  - If the capture function remains unused and the Capture Register contents are 'don't care' then the corresponding input pins 'CTnI', with 'n = 0 ... 3', may be used as positive and/or negative edge triggered external interrupts INT2 to INT5. But note that they can not terminate the Idle mode because the Timer 2 is switched off then
- Timer T2, 8 separate interrupts:
  - 4 capture interrupts
  - 3 compare interrupts
  - an overflow interrupt
- ADC end-of-conversion interrupt
- CAN-controller interrupt
- UART serial I/O port interrupt.

Each interrupt vectors to a separate location in Program Memory for its service program. Each source can be individually enabled or disabled by a corresponding bit in the IEN0 or IEN1 register, moreover each interrupt may be programmed to a HIGH or LOW priority level using a corresponding bit in the IP0 or IP1 register. Also all enabled sources can be globally disabled or enabled. Both external interrupts can be programmed to be level-activated or transition-activated, and an active LOW level allows 'wire-ORing' of several interrupt sources to the input pin.

# 8-bit microcontroller with on-chip CAN

# P8xC592

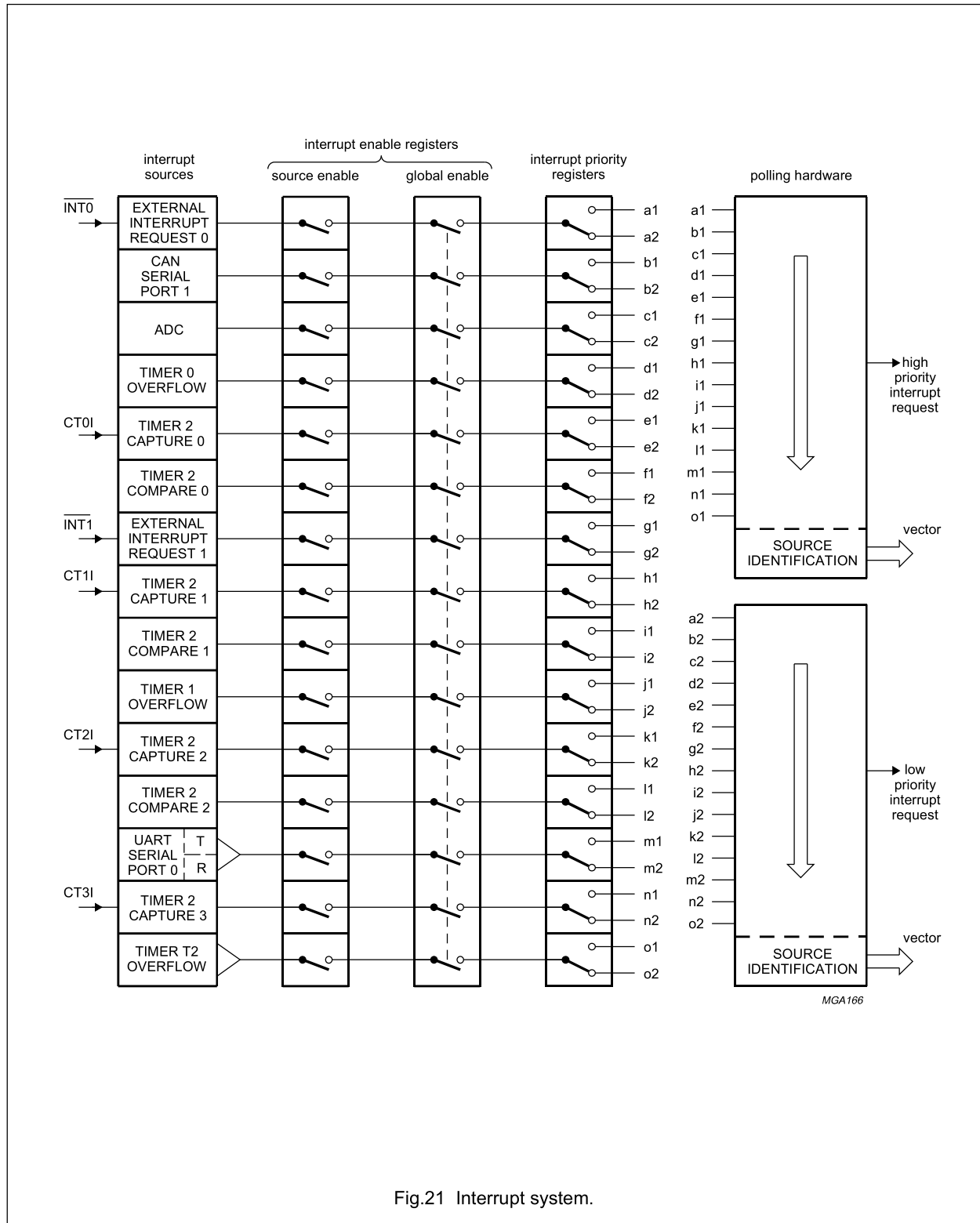

Fig.21 Interrupt system.

## 8-bit microcontroller with on-chip CAN

P8xC592

**14.1 Interrupt Enable and Priority Registers**

## 14.1.1 INTERRUPT ENABLE REGISTER 0 (IEN0)

**Table 71** Interrupt Enable register 0 (address A8H)

7	6	5	4	3	2	1	0
EA	EAD	ES1	ES0	ET1	EX1	ET0	EX0

**Table 72** Description of the IEN0 bits

BIT	SYMBOL	FUNCTION
7	EA	<b>General enable/disable control.</b> If bit EA is: LOW, then no interrupt is enabled. HIGH, then any individually enabled interrupt will be accepted.
6	EAD	Enable ADC interrupt.
5	ES1	Enable SIO1 (CAN) interrupt.
4	ES0	Enable SIO0 (UART) interrupt.
3	ET1	Enable Timer 1 interrupt.
2	EX1	Enable External 1 interrupt.
1	ET0	Enable Timer 0 interrupt.
0	EX0	Enable External 0 interrupt.

## 14.1.2 INTERRUPT ENABLE REGISTER 1 (IEN1)

**Table 73** Interrupt Enable register 0 (address E8H)

7	6	5	4	3	2	1	0
ET2	ECM2	ECM1	ECM0	ECT3	ECT2	ECT1	ECT0

**Table 74** Description of the IEN1 bits

Logic 0 = interrupt disabled; Logic 1 = interrupt enabled.

BIT	SYMBOL	FUNCTION
7	ET2	Enable T2 overflow interrupt(s).
6	ECM2	Enable T2 comparator 2 interrupt.
5	ECM1	Enable T2 comparator 1 interrupt.
4	ECM0	Enable T2 comparator 0 interrupt.
3	ECT3	Enable T2 capture register 3 interrupt.
2	ECT1	Enable T2 capture register 2 interrupt.
1	ECT1	Enable T2 capture register 1 interrupt.
0	ECT0	Enable T2 capture register 0 interrupt.



## 8-bit microcontroller with on-chip CAN

## P8xC592

## 14.1.3 INTERRUPT PRIORITY REGISTER 0 (IP0)

**Table 75** Interrupt Priority register 0 (address B8H)

7	6	5	4	3	2	1	0
–	PAD	PS1	PS0	PT1	PX1	PT0	PX0

**Table 76** Description of the IP0 bits

BIT	SYMBOL	FUNCTION
7	–	Not used.
6	PAD	ADC interrupt priority level.
5	PS1	SIO1 (CAN) interrupt priority level.
4	PS0	SIO0 (UART) interrupt priority level.
3	PT1	Timer 1 interrupt priority level.
2	PX1	External interrupt 1 priority level.
1	PT0	Timer 0 interrupt priority level.
0	PX0	External interrupt 0 priority level.

## 14.1.4 INTERRUPT PRIORITY REGISTER 1 (IP1)

**Table 77** Interrupt Priority register 1 (address F8H)

7	6	5	4	3	2	1	0
PT2	PCM2	PCM1	PCM0	PCT3	PCT2	PCT1	PCT0

**Table 78** Description of the IP1 bits

Logic 0 = low priority; Logic 1 = high priority.

BIT	SYMBOL	FUNCTION
7	PT2	T2 overflow interrupt(s) priority level.
6	PCM2	T2 comparator 2 priority interrupt level.
5	PCM1	T2 comparator 1 priority interrupt level.
4	PCM0	T2 comparator 0 priority interrupt level.
3	PCT3	T2 capture register 3 priority interrupt level.
2	PCT2	T2 capture register 2 priority interrupt level.
1	PCT1	T2 capture register 1 priority interrupt level.
0	PCT0	T2 capture register 0 priority interrupt level.

## 8-bit microcontroller with on-chip CAN

## P8xC592

## 14.2 Interrupt Vectors

The vector indicates the Program Memory location where the appropriate interrupt service routine starts (see Table 79).

**Table 79** Interrupt vectors

SOURCE	BIT	VECTOR
External 0	X0	0003H
Timer 0 overflow	T0	000BH
External 1	X1	0013H
Timer 1 overflow	T1	001BH
Serial I/O 0 (UART)	S0	0023H
Serial I/O 1 (CAN)	S1	002BH
T2 capture 0	CT0	0033H
T2 capture 1	CT1	003BH
T2 capture 2	CT2	0043H
T2 capture 3	CT3	004BH
ADC completion	ADC	0053H
T2 compare 0	CM0	005BH
T2 compare 1	CM1	0063H
T2 compare 2	CM2	006BH
T2 overflow	T2	0073H

## 14.3 Interrupt Priority

Each interrupt source can be either high priority or low priority. If both priorities are requested simultaneously, the processor will branch to the high priority vector. If there are simultaneous requests from sources of the same priority, then interrupts will be serviced in the following order:

X0, S1, ADC, T0, CT0, CM0, X1, CT1, CM1, T1, CT2, CM2, S0, CT3, T2.

A low priority interrupt routine can only be interrupted by a high priority interrupt. A high priority interrupt routine can not be interrupted.

## 15 POWER REDUCTION MODES

The P8xC592 has three software-selectable modes to reduce power consumption. These are:

- Sleep mode, affecting the CAN-controller only
- Idle mode, affecting the
  - CPU (halted)
  - Timer 2 (stopped and reset)
  - PWM0, PWM1 (reset, output = HIGH)
  - ADC (aborted if in progress)
- Power-down mode, affecting the whole P8xC592 device.

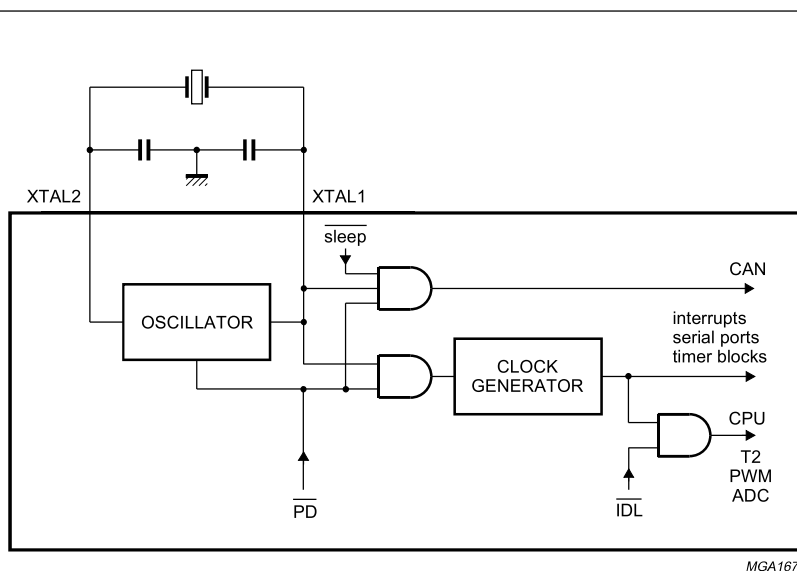

Fig.22 Internal Sleep, Idle and Power-down clock configuration.

## 8-bit microcontroller with on-chip CAN

## P8xC592

## 15.1 Power Control Register (PCON)

Table 80 Power Control Register (address 87H)

7	6	5	4	3	2	1	0
SMOD	–	–	WLE	GF1	GF0	PD	IDL

Table 81 Description of the PCON bits

BIT	SYMBOL	FUNCTION
7	SMOD	<b>Double baud rate bit.</b> When set to logic 1 the baud rate is doubled when the serial port SIO0 is being used in Modes 1, 2 and 3.
6	–	Reserved.
5	–	
4	WLE	<b>Watchdog Load Enable.</b> This flag must be set by software prior to loading T3 (Watchdog timer). It is cleared when T3 is loaded.
3	GF1	<b>General purpose flag bits.</b>
2	GF0	
1	PD	<b>Power-down bit.</b> Setting this bit activates Power-down mode (note 1). It can only be set if input $\overline{EW}$ is HIGH.
0	IDL	<b>Idle mode bit.</b> Setting this bit activates the Idle mode (note 1).

## Note

1. If PD and IDL are set to HIGH at the same time, PD takes precedence. The reset value of PCON is 0XX00000B.

## 15.2 CAN Sleep Mode

In order to reduce power consumption of the P8xC592 the CAN-controller may be switched off (disconnecting the internal clock) by setting the CAN Command Register bit 4 (Sleep) HIGH. The CAN-controller leaves this Sleep mode by detecting either activity on the CAN-bus (dominant bit-level on CRX0/CRX1; see Chapter 5, Table 1) or by setting the Sleep bit to LOW. As the CPU can not only write to the Sleep bit, but can also read it, the CAN-controller status can be determined directly.

## 15.3 Idle Mode

The instruction that sets bit PCON.0 to HIGH is the last one executed in the normal operating mode before Idle mode is activated.

Once in the Idle mode, the CPU status is preserved in its entirety: the Stack Pointer, Program Counter, Program Status Word, Accumulator, RAM and all other registers maintain their data during Idle mode. The status of the external pins during Idle mode is shown in see Table 82.

There are three ways to terminate the Idle mode:

- Activation of any enabled interrupt will cause PCON.0 to be cleared by hardware, provided that the interrupt source is active during Idle mode. After the interrupt is serviced, the program continues with the instruction immediately after the one, at which the interrupt request was detected.
- The flag bits GF0 and GF1 may be used to determine whether the interrupt was received during normal execution or during the Idle mode. For example, the instruction that writes to PCON.0 can also set or clear one or both flag bits. When Idle mode is terminated by an interrupt, the service routine can examine the status of the flag bits.
- Another way of terminating the Idle mode is an external hardware reset. Since the oscillator is still running, the reset signal is required to be active only for two machine cycles (24 oscillator periods) to complete the reset operation.
- The third way is the internally generated watchdog reset after an overflow of Timer 3.

## 8-bit microcontroller with on-chip CAN

## P8xC592

**15.4 Power-down Mode**

The instruction that sets bit PCON.1 to HIGH, is the last one executed before entering the Power-down mode. In Power-down mode the oscillator of the P8xC592 is stopped. If the CAN-controller is in use, it is recommended to set it into Sleep mode before entering Power-down mode. However, setting PCON.1 to HIGH also sets the Sleep bit (CAN-controller Command Register bit 4) to HIGH.

The P8xC592 leaves Power-down mode either by a hardware reset or by a CAN Wake-Up interrupt (due to activity on the CAN-bus), if the SIO1 (CAN) interrupt source is enabled (contents of register IEN0 = 1X1XXXXXB).

A hardware reset affects the whole P8xC592, but leaves the contents of the on-chip RAM unchanged (CAN-controller-and CPU's SFRs are reset, see Section 13.5.2, Chapter 17 and Table 40). A CAN Wake-Up interrupt during Power-down mode causes a reset output pulse with a width of 6144 machine cycles (4.6 ms with  $f_{CLK} = 16$  MHz). All hardware except that for the CAN-controller of the P8xC592 is reset (i.e. the contents of all CAN-controller registers are preserved).

A capacitance connected to the RST pin can be used to lengthen the internally generated reset pulse. If the pulse exceeds 8192 machine cycles, the CAN-controller part is reset too.

**Table 82** Status of external pins during Idle and Power-down modes

MODE	PROGRAM	ALE	$\overline{PSEN}$	PORT0	PORT1 <sup>(1)</sup>	PORT2	PORT3	PORT4	PWM0/ PWM1
Idle	internal	1	1	port data	port data	port data	port data	port data	1
	external	1	1	floating	port data	address	port data	port data	1
Power-down	internal	0	0	port data	port data	port data	port data	port data	1
	external	0	0	floating	port data	port data	port data	port data	1

**Note**

1. If the port pins P1.6 and P1.7 are used as the CAN transmitter outputs (CTX0 and CTX1), then during Sleep and Power-down mode these pins output a 'recessive' level (see Sections 13.5.2 and 13.5.11).

## 8-bit microcontroller with on-chip CAN

## P8xC592

## 16 OSCILLATOR CIRCUITRY

The oscillator circuitry of the P8xC592 is a single-stage inverting amplifier in a Pierce oscillator configuration. The circuitry between XTAL1 and XTAL2 is basically an inverter biased to the transfer point. Either a crystal or ceramic resonator can be used as the feedback element to complete the oscillator circuitry. Both are operated in parallel resonance. XTAL1 (pin 34) is the high gain amplifier input, and XTAL2 (pin 33) is the output (see Fig.23). If XTAL1 is driven from an external source, XTAL2 must be left open (see Fig.24).

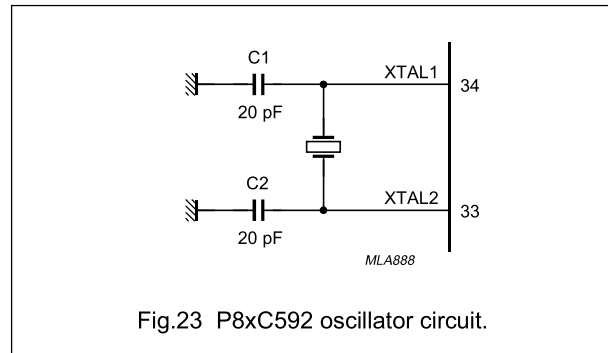

Fig.23 P8xC592 oscillator circuit.

## 17 RESET CIRCUITRY

The reset pin RST is connected to a Schmitt trigger for noise rejection (see Fig.25). A reset is accomplished by holding the RST pin HIGH for at least two machine cycles (24 oscillator periods). The CPU responds by executing an internal reset. During reset ALE and PSEN output a HIGH level. In order to perform a correct reset, this level must not be affected by external elements.

Also with the P8xC592, the RST line can be pulled HIGH internally by a pull-up transistor activated by the Watchdog timer T3. The length of the output pulse from T3 is 3 machine cycles. A pulse of such short duration is necessary in order to recover from a processor or system fault as fast as possible.

During Power-down a reset could be generated internally via the CAN Wake-Up interrupt. Then the RST pin is pulled HIGH for 6144 machine cycles. In this case the CAN-controller is not reset.

If the Watchdog timer or the CAN Wake-Up interrupt is used to reset external devices, the usual capacitor arrangement for Power-on-reset (see Fig.26) should not be used.

However, the internal reset is forced, independent of the external level on the RST pin.

The MAIN RAM and AUXILIARY RAM are not affected. When  $V_{DD}$  is turned on, the RAM content is indeterminate. A reset leaves the internal registers as shown in Table 83.

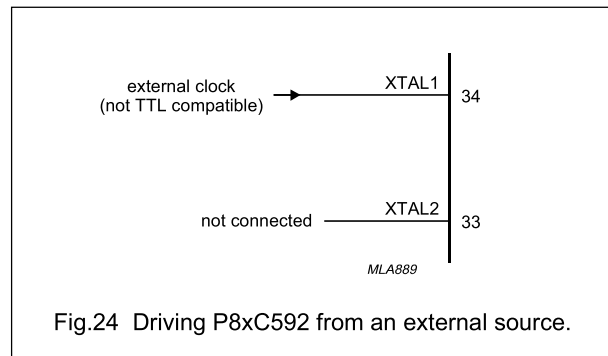

Fig.24 Driving P8xC592 from an external source.

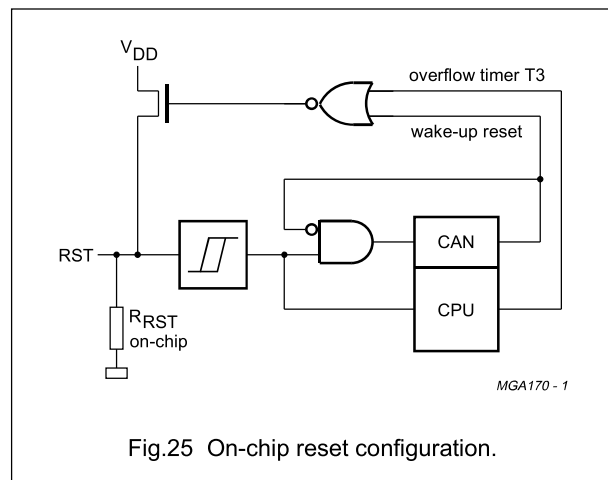

Fig.25 On-chip reset configuration.

## 8-bit microcontroller with on-chip CAN

## P8xC592

**Table 83** Internal registers' contents after a reset

X = undefined state.

REGISTER	7	6	5	4	3	2	1	0
<b>CPU part</b>								
ACC	0	0	0	0	0	0	0	0
ADC0	X	X	0	0	0	0	0	0
ADCH	X	X	X	X	X	X	X	X
B	0	0	0	0	0	0	0	0
CML0 to CML2	0	0	0	0	0	0	0	0
CMH0 to CMH2	0	0	0	0	0	0	0	0
CTCON	0	0	0	0	0	0	0	0
CTL0 to CTL3	X	X	X	X	X	X	X	X
CTH0 to CTH3	X	X	X	X	X	X	X	X
DPL	0	0	0	0	0	0	0	0
DPH	0	0	0	0	0	0	0	0
IEN0	0	0	0	0	0	0	0	0
IEN1	0	0	0	0	0	0	0	0
IP0	X	0	0	0	0	0	0	0
IP1	0	0	0	0	0	0	0	0
PCH	0	0	0	0	0	0	0	0
PCL	0	0	0	0	0	0	0	0
PCON	0	X	X	0	0	0	0	0
PSW	0	0	0	0	0	0	0	0
PWM0	0	0	0	0	0	0	0	0
PCWM1	0	0	0	0	0	0	0	0
PCWMP	0	0	0	0	0	0	0	0
P0 to P4	1	1	1	1	1	1	1	1
P5	X	X	X	X	X	X	X	X
RTE	0	0	0	0	0	0	0	0
S0BUF	X	X	X	X	X	X	X	X
SOCON	0	0	0	0	0	0	0	0

REGISTER	7	6	5	4	3	2	1	0
CANSTA	0	0	0	0	1	1	0	0
CANCON	X	X	X	0	0	0	0	0
CANDAT	X	X	X	X	X	X	X	X
CANADR	0	X	1	0	0	1	0	0
SP	0	0	0	0	0	1	1	1
STE	1	1	0	0	0	0	0	0
TCON	0	0	0	0	0	0	0	0
TH0, TH1	0	0	0	0	0	0	0	0
TMH2	0	0	0	0	0	0	0	0
TL0, TL1	0	0	0	0	0	0	0	0
TML2	0	0	0	0	0	0	0	0
TMOD	0	0	0	0	0	0	0	0
TM2CON	0	0	0	0	0	0	0	0
TM2IR	0	0	0	0	0	0	0	0
T3	0	0	0	0	0	0	0	0
<b>CAN part</b>								
CR	0	X	1	X	X	X	X	1
CMR	1	1	X	0	X	X	X	X
SR	0	0	0	0	1	1	0	0
IR	X	X	X	0	0	0	0	0
ACR	X	X	X	X	X	X	X	X
AMR	X	X	X	X	X	X	X	X
BTR0	X	X	X	X	X	X	X	X
BTR1	X	X	X	X	X	X	X	X
OCR	X	X	X	X	X	X	X	X
TR	X	X	X	X	X	X	X	X
TXB 10 to 19	X	X	X	X	X	X	X	X
RXB 20 to 29	X	X	X	X	X	X	X	X

## 8-bit microcontroller with on-chip CAN

## P8xC592

## 17.1 Power-on Reset

If the RST pin is connected to  $V_{DD}$  via a  $2.2\ \mu\text{F}$  capacitor, as shown in Fig.26, an automatic reset can be obtained by switching on  $V_{DD}$  (provided its rise time is  $<10\ \text{ms}$ ). The decrease of the RST pin voltage depends on the capacitor and the internal resistor  $R_{RST}$ . That voltage must remain above the lower threshold for at minimum the oscillator start-up time plus 2 machine cycles.

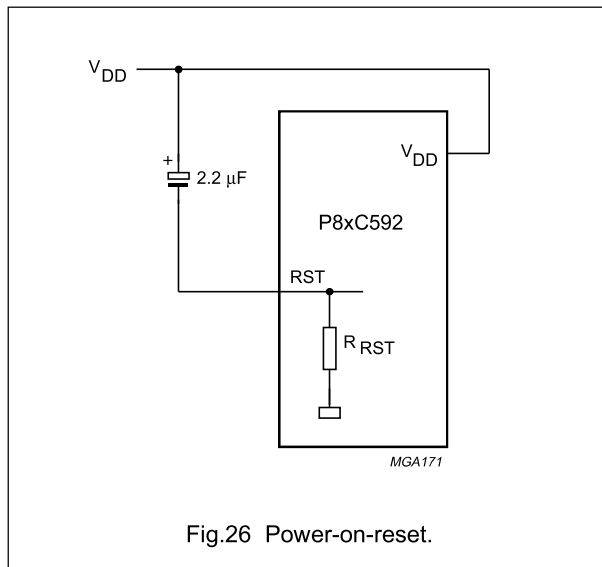

## 18 INSTRUCTION SET

The P8xC592 uses the powerful instruction set of the P80C51. It consists of 49 single-byte, 45 two-byte and 17 three-byte instructions. Using a 16 MHz quartz, 64 of the instructions are executed in  $0.75\ \mu\text{s}$ , 45 in  $1.5\ \mu\text{s}$  and the multiply, divide instructions in  $3\ \mu\text{s}$ . A summary of the instruction set is given in Tables 84, 85, 86, 87 and 88.

## 18.1 Addressing Modes

Most instructions have a 'destination/source' field that specifies the data type, addressing modes and operands involved. For all these instructions, except from MOVs, the destination operand is also a source operand (e.g. ADD A, R7).

Five types of addressing modes are used:

- Register Addressing,
  - R0 to R7 (4 banks)
  - A,B,C (bit), AB (2 bytes), DPTR (double byte).
- Direct Addressing,
  - lower 128 bytes of internal MAIN RAM (including the 4 R0 to R7 register banks)
  - Special Function Registers (SFRs)
  - 128 bits in a subset of the internal MAIN RAM (see Fig.5)
  - 128 bits in a subset of the Special Function Registers (see Figs 6 and 7).
- Register-Indirect Addressing,
  - internal RAM (@R0, @R1, @SP [PUSH/POP])
  - internal AUXILIARY RAM (@R0, @R1, @DPTR)
  - external Data Memory (@DPTR).
- Immediate Addressing,
  - Program Memory (in-code 8 bit or 16 bit constant).
- Base-Register-plus Index-Register-Indirect Addressing,
  - Program Memory look-up table (@DPTR+A, @PC+A).

The first three addressing modes are usable for destination operands.

## 8-bit microcontroller with on-chip CAN

P8xC592

**18.2 Instruction Set**

For the description of the **Data Addressing Modes** and **Hexadecimal opcode cross-reference** see Table 88.

**Table 84** Instruction set description: Arithmetic operations

MNEMONIC	DESCRIPTION	BYTES	CYCLES	OPCODE (HEX)	
<b>Arithmetic operations</b>					
ADD	A,Rr	Add register to A	1	1	2*
ADD	A,direct	Add direct byte to A	2	1	25
ADD	A,@Ri	Add indirect RAM to A	1	1	26, 27
ADD	A,#data	Add immediate data to A	2	1	24
ADDC	A,Rr	Add register to A with carry flag	1	1	3*
ADDC	A,direct	Add direct byte to A with carry flag	2	1	35
ADDC	A,@Ri	Add indirect RAM to A with carry flag	1	1	36, 37
ADDC	A,#data	Add immediate data to A with carry flag	2	1	34
SUBB	A,Rr	Subtract register from A with borrow	1	1	9*
SUBB	A,direct	Subtract direct byte from A with borrow	2	1	95
SUBB	A,@Ri	Subtract indirect RAM from A with borrow	1	1	96, 97
SUBB	A,#data	Subtract immediate data from A with borrow	2	1	94
INC	A	Increment A	1	1	04
INC	Rr	Increment register	1	1	0*
INC	direct	Increment direct byte	2	1	05
INC	@Ri	Increment indirect RAM	1	1	06, 07
DEC	A	Decrement A	1	1	14
DEC	Rr	Decrement register	1	1	1*
DEC	direct	Decrement direct byte	2	1	15
DEC	@Ri	Decrement indirect RAM	1	1	16, 17
INC	DPTR	Increment data pointer	1	2	A3
MUL	AB	Multiply A and B	1	4	A4
DIV	AB	Divide A by B	1	4	84
DA	A	Decimal adjust A	1	1	D4



## 8-bit microcontroller with on-chip CAN

## P8xC592

**Table 85** Instruction set description: Logic operations

MNEMONIC	DESCRIPTION	BYTES	CYCLES	OPCODE (HEX)
<b>Logic operations</b>				
ANL A,Rr	AND register to A	1	1	5*
ANL A,direct	AND direct byte to A	2	1	55
ANL A,@Ri	AND indirect RAM to A	1	1	56, 57
ANL A,#data	AND immediate data to A	2	1	54
ANL direct,A	AND A to direct byte	2	1	52
ANL direct,#data	AND immediate data to direct byte	3	2	53
ORL A,Rr	OR register to A	1	1	4*
ORL A,direct	OR direct byte to A	2	1	45
ORL A,@Ri	OR indirect RAM to A	1	1	46, 47
ORL A,#data	OR immediate data to A	2	1	44
ORL direct,A	OR A to direct byte	2	1	42
ORL direct,#data	OR immediate data to direct byte	3	2	43
XRL A,Rr	Exclusive-OR register to A	1	1	6*
XRL A,direct	Exclusive-OR direct byte to A	2	1	65
XRL A,@Ri	Exclusive-OR indirect RAM to A	1	1	66, 67
XRL A,#data	Exclusive-OR immediate data to A	2	1	64
XRL direct,A	Exclusive-OR A to direct byte	2	1	62
XRL direct,#data	Exclusive-OR immediate data to direct byte	3	2	63
CLR A	Clear A	1	1	E4
CPL A	Complement A	1	1	F4
RL A	Rotate A left	1	1	23
RLC A	Rotate A left through the carry flag	1	1	33
RR A	Rotate A right	1	1	03
RRC A	Rotate A right through the carry flag	1	1	13
SWAP A	Swap nibbles within A	1	1	C4

## 8-bit microcontroller with on-chip CAN

## P8xC592

**Table 86** Instruction set description: Data transfer

MNEMONIC	DESCRIPTION	BYTES	CYCLES	OPCODE (HEX)
<b>Data transfer</b>				
MOV A,Rr	Move register to A	1	1	E*
MOV A,direct (note 1)	Move direct byte to A	2	1	E5
MOV A,@Ri	Move indirect RAM to A	1	1	E6, E7
MOV A,#data	Move immediate data to A	2	1	74
MOV Rr,A	Move A to register	1	1	F*
MOV Rr,direct	Move direct byte to register	2	2	A*
MOV Rr,#data	Move immediate data to register	2	1	7*
MOV direct,A	Move A to direct byte	2	1	F5
MOV direct,Rr	Move register to direct byte	2	2	8*
MOV direct,direct	Move direct byte to direct	3	2	85
MOV direct,@Ri	Move indirect RAM to direct byte	2	2	86, 87
MOV direct,#data	Move immediate data to direct byte	3	2	75
MOV @Ri,A	Move A to indirect RAM	1	1	F6, F7
MOV @Ri,direct	Move direct byte to indirect RAM	2	2	A6, A7
MOV @Ri,#data	Move immediate data to indirect RAM	2	1	76, 77
MOV DPTR,#data16	Load data pointer with a 16-bit constant	3	2	90
MOVC A,@A+DPTR	Move code byte relative to DPTR to A	1	2	93
MOVC A,@A+PC	Move code byte relative to PC to A	1	2	83
MOVX A,@Ri	Move external RAM (8-bit address) to A	1	2	E2, E3
MOVX A,@DPTR	Move external RAM (16-bit address) to A	1	2	E0
MOVX @Ri,A	Move A to external RAM (8-bit address)	1	2	F2, F3
MOVX @DPTR,A	Move A to external RAM (16-bit address)	1	2	F0
PUSH direct	Push direct byte onto stack	2	2	C0
POP direct	Pop direct byte from stack	2	2	D0
XCH A,Rr	Exchange register with A	1	1	C*
XCH A,direct	Exchange direct byte with A	2	1	C5
XCH A,@Ri	Exchange indirect RAM with A	1	1	C6, C7
XCHD A,@Ri	Exchange LOW-order digit indirect RAM with A	1	1	D6, D7

**Note**

- MOV A,ACC is not permitted.

## 8-bit microcontroller with on-chip CAN

P8xC592

**Table 87** Instruction set description: Boolean variable manipulation, Program and machine control

MNEMONIC		DESCRIPTION	BYTES	CYCLES	OPCODE (HEX)
<b>Boolean variable manipulation</b>					
CLR	C	Clear carry flag	1	1	C3
CLR	bit	Clear direct bit	2	1	C2
SETB	C	Set carry flag	1	1	D3
SETB	bit	Set direct bit	2	1	D2
CPL	C	Complement carry flag	1	1	B3
CPL	bit	Complement direct bit	2	1	B2
ANL	C,bit	AND direct bit to carry flag	2	2	82
ANL	C,/bit	AND complement of direct bit to carry flag	2	2	B0
ORL	C,bit	OR direct bit to carry flag	2	2	72
ORL	C,/bit	OR complement of direct bit to carry flag	2	2	A0
MOV	C,bit	Move direct bit to carry flag	2	1	A2
MOV	bit,C	Move carry flag to direct bit	2	2	92
<b>Program and machine control</b>					
ACALL	addr11	Absolute subroutine call	2	2	•1
LCALL	addr16	Long subroutine call	3	2	12
RET		Return from subroutine	1	2	22
RETI		Return from interrupt	1	2	32
AJMP	addr11	Absolute jump	2	2	♦1
LJMP	addr16	Long jump	3	2	02
SJMP	rel	Short jump (relative address)	2	2	80
JMP	@A+DPTR	Jump indirect relative to the DPTR	1	2	73
JZ	rel	Jump if A is zero	2	2	60
JNZ	rel	Jump if A is not zero	2	2	70
JC	rel	Jump if carry flag is set	2	2	40
JNC	rel	Jump if carry flag is not set	2	2	50
JB	bit,rel	Jump if direct bit is set	3	2	20
JNB	bit,rel	Jump if direct bit is not set	3	2	30
JBC	bit,rel	Jump if direct bit is set and clear bit	3	2	10
CJNE	A,direct,rel	Compare direct to A and jump if not equal	3	2	B5
CJNE	A,#data,rel	Compare immediate to A and jump if not equal	3	2	B4
CJNE	Rr,#data,rel	Compare immediate to register and jump if not equal	3	2	B*
CJNE	@Ri,#data,rel	Compare immediate to indirect and jump if not equal	3	2	B6, B7
DJNZ	Rr,rel	Decrement register and jump if not zero	2	2	D*
DJNZ	direct,rel	Decrement direct and jump if not zero	3	2	D5
NOP		No operation	1	1	00

## 8-bit microcontroller with on-chip CAN

P8xC592

**Table 88** Description of the mnemonics in the Instruction set

MNEMONIC	DESCRIPTION
<b>Data addressing modes</b>	
Rr	Working register R0-R7.
direct	128 internal RAM locations and any special function register (SFR).
@Ri	Indirect internal RAM location addressed by register R0 or R1 of the actual register bank.
#data	8-bit constant included in instruction.
#data 16	16-bit constant included as bytes 2 and 3 of instruction.
bit	Direct addressed bit in internal RAM or SFR.
addr16	16-bit destination address. Used by LCALL and LJMP. The branch will be anywhere within the 64 kbytes Program Memory address space.
addr11	11-bit destination address. Used by ACALL and AJMP. The branch will be within the same 2 kbytes page of Program Memory as the first byte of the following instruction.
rel	Signed (two's complement) 8-bit offset byte. Used by SJMP and all conditional jumps. Range is -128 to +127 bytes relative to first byte of the following instruction.
<b>Hexadecimal opcode cross-reference</b>	
*	8, 9, A, B, C, D, E, F.
•	1, 3, 5, 7, 9, B, D, F.
♦	0, 2, 4, 6, 8, A, C, E.

8-bit microcontroller with on-chip CAN

P8xC592

Table 89 Instruction map

↓	First hexadecimal character of opcode				← Second hexadecimal character of opcode →				8 9 A B C D E F								
	0	1	2	3	4	5	6	7	8	9	A	B	C	D	E	F	
0	NOP	AJMP addr11	LJMP addr16	RR A	INC A	INC direct	INC @Ri 0	1	0	0	1	2	3	4	5	6	7
1	JBC bit,rel	ACALL addr11	LCALL addr16	RRC A	DEC A	DEC direct	DEC @Ri 0	1	0	0	1	2	3	4	5	6	7
2	JB bit,rel	AJMP addr11	RET	RL A	ADD A,#data	ADD A,direct	ADD A,@Ri 0	1	0	0	1	2	3	4	5	6	7
3	JNB bit,rel	ACALL addr11	RETI	RLC A	ADDC A,#data	ADDC A,direct	ADDC A,@Ri 0	1	0	0	1	2	3	4	5	6	7
4	JC rel	AJMP addr11	ORL direct,A	ORL direct,#data	ORL A,#data	ORL A,direct	ORL A,@Ri 0	1	0	0	1	2	3	4	5	6	7
5	JNC rel	ACALL addr11	ANL direct,A	ANL direct,#data	ANL A,#data	ANL A,direct	ANL A,@Ri 0	1	0	0	1	2	3	4	5	6	7
6	JZ rel	AJMP addr11	XRL direct,A	XRL direct,#data	XRL A,#data	XRL A,direct	XRL A,@Ri 0	1	0	0	1	2	3	4	5	6	7
7	JNZ rel	ACALL addr11	ORL C,bit	JMP @A+DPTR	MOV A,#data	MOV direct,#data	MOV @Ri,#data 0	1	0	0	1	2	3	4	5	6	7
8	SJMP rel	AJMP addr11	ANL C,bit	MOVC A,@A+PC	DIV AB	MOV direct,direct	MOV direct,@Ri 0	1	0	0	1	2	3	4	5	6	7
9	MOV DTPR,#data16	ACALL addr11	MOV bit,C	MOVC A,@A+DPTR	SUBB A,#data	SUBB A,direct	SUBB A,@Ri 0	1	0	0	1	2	3	4	5	6	7
A	ORL C,/bit	AJMP addr11	MOV bit,C	INC DPTR	MUL AB		MOV @Ri,direct 0	1	0	0	1	2	3	4	5	6	7
B	ANL C,/bit	ACALL addr11	CPL bit	CPL C	CJNE A,#data,rel	CJNE A,direct,rel	CJNE @Ri,#data,rel 0	1	0	0	1	2	3	4	5	6	7
C	PUSH direct	AJMP addr11	CLR bit	CLR C	SWAP A	XCH A,direct	XCH A,@Ri 0	1	0	0	1	2	3	4	5	6	7
D	POP direct	ACALL addr11	SETB bit	SETB C	DA A	DJNZ direct,rel	XCHD A,@Ri 0	1	0	0	1	2	3	4	5	6	7
E	MOVX A,@DTPR	AJMP addr11	MOVX A,@Ri	MOVX A,@Ri	CLR A	MOV A,direct <sup>(1)</sup>	MOV A,@Ri 0	1	0	0	1	2	3	4	5	6	7
F	MOVX @DTPR,A	ACALL addr11	MOVX @Ri,A	MOVX @Ri,A	CPL A	MOV direct,A	MOV @Ri,A 0	1	0	0	1	2	3	4	5	6	7

Note

1. MOV A, ACC is not a valid instruction.

## 8-bit microcontroller with on-chip CAN

## P8xC592

**19 ABSOLUTE MAXIMUM RATINGS** (note 1)

In accordance with the Absolute Maximum Rating System (IEC 134).

SYMBOL	PARAMETER	MIN.	MAX.	UNIT
$V_{DD}$	voltage on $V_{DD}$ pin	-0.5	+6.5	V
$V_{I1}$	input voltage on any pin (except CTX0, CTX1, CRX0, CRX1 and $\overline{EA}/V_{PP}$ )	-0.5	$V_{DD} + 0.5$	V
$V_{I2}$	input voltage on $\overline{EA}/V_{PP}$ to $V_{SS}$	-0.5	+13	V
$I_I, I_O$	input/output current on any single I/O pin (except from CTX0 and CTX1)	-	$\pm 10$	mA
$I_{OT}$	sink current of CTX0, CTX1 together	-	30	mA
	source current of CTX0, CTX1 together	-	-20	mA
$P_{tot}$	total power dissipation (note 2)	-	1.0	W
$T_{stg}$	storage temperature range	-65	+150	°C
$T_{amb}$	operating ambient temperature range:			
	P8xC592 FFA	-40	+85	°C
	P8xC592 FHA	-40	+125	°C

**Notes**

- The following applies to the Absolute Maximum Ratings:
  - Stresses above those listed under Absolute Maximum Ratings may cause permanent damage to the device. This is a stress rating only and functional operation of the device at these or any conditions other than those described in the Chapters 20 "DC characteristics" and 21 "AC characteristics" of this specification is not implied.
  - This product includes circuitry specifically designed for the protection of its internal devices from the damaging effect of excessive static charge. However, it is suggested that conventional precautions be taken to avoid applying greater than the rated maxima.
  - Parameters are valid over operating temperature range unless otherwise specified. All voltages are with respect to  $V_{SS}$  unless otherwise noted.
- This value is based on the maximum allowable die temperature and the thermal resistance of the package, not on device power consumption.

## 8-bit microcontroller with on-chip CAN

## P8xC592

**20 DC CHARACTERISTICS**

$V_{DD} = 5\text{ V} \pm 10\%$ ;  $V_{SS} = 0\text{ V}$ ; all voltages with respect to  $V_{SS}$  unless otherwise specified.

$T_{amb} = -40$  to  $+125\text{ }^{\circ}\text{C}$  for the **P8xC592FHA**;  $T_{amb} = -40$  to  $+85\text{ }^{\circ}\text{C}$  for the **P8xC592FFA**.

SYMBOL	PARAMETER	CONDITIONS	MIN.	MAX.	UNIT
<b>Supply (digital part)</b>					
$V_{DD}$	supply voltage		4.5	5.5	V
$I_{DD}$	operating supply current	$f_{CLK} = 16\text{ MHz}$ ; note 1	–	50	mA
$I_{DD(ID)}$	supply current Idle mode	$f_{CLK} = 16\text{ MHz}$ ; note 2	–	15	mA
$I_{DD(IS)}$	supply current Idle & Sleep mode	$f_{CLK} = 16\text{ MHz}$ ; note 3	–	10	mA
$I_{DD(PD)}$	supply current Power-down mode:	note 4			
	P8xC592 FHA		–	150	$\mu\text{A}$
	P8xC592 xFx		–	50	$\mu\text{A}$
<b>Inputs</b>					
$V_{IL}$	LOW level input voltage (except $\overline{EA}$ , CRX0 and CRX1)		–0.5	$0.2V_{DD} - 0.1$	V
$V_{IL1}$	LOW level input voltage $\overline{EA}$		–0.5	$0.2V_{DD} - 0.3$	V
$V_{IH}$	HIGH level input voltage (except RST, XTAL1, CRX0, CRX1)		$0.2V_{DD} + 0.9$	$V_{DD} + 0.5$	V
$V_{IH1}$	HIGH level input voltage (RST and XTAL1)		$0.7V_{DD}$	$V_{DD} + 0.5$	V
$I_{IL}$	LOW level input current Ports 1, 2, 3 and 4	$V_I = 0.45\text{ V}$	–	–50	$\mu\text{A}$
$I_{TL}$	input current HIGH-to-LOW transition Ports 1, 2, 3 and 4 (except P1.6 and P1.7)	$V_I = 2.0$ to $0.45\text{ V}$	–	–650	$\mu\text{A}$
$I_{LI1}$	input leakage current Port 0, $\overline{EA}$ , STADC, $\overline{EW}$ , P1.6, P1.7	$0.45\text{ V} < V_I < V_{DD}$	–	$\pm 10$	$\mu\text{A}$
$I_{LI2}$	input leakage current Port 5	$0.45\text{ V} < V_I < V_{DD}$	–	$\pm 1$	$\mu\text{A}$
<b>Outputs</b>					
$V_{OL}$	LOW level output voltage Ports 1, 2, 3 and 4 (except P1.6 and P1.7)	$I_{OL} = 1.6\text{ mA}$ ; note 5	–	0.45	V
$V_{OL1}$	LOW level output voltage Port 0, ALE, $\overline{PSEN}$ , $\overline{PWM0}$ , $\overline{PWM1}$ , P1.6, P1.7	$I_{OL} = 3.2\text{ mA}$ ; note 5	–	0.45	V
$V_{OH}$	HIGH level output voltage Ports 1, 2, 3 and 4 (except P1.6 and P1.7)	$I_{OH} = -60\text{ }\mu\text{A}$ $I_{OH} = -25\text{ }\mu\text{A}$ $I_{OH} = -10\text{ }\mu\text{A}$	2.4 $0.75V_{DD}$ $0.9V_{DD}$	– – –	V V V
$V_{OH1}$	HIGH level output voltage Port 0 in external bus mode, ALE, $\overline{PSEN}$ , $\overline{PWM0}$ , $\overline{PWM1}$	$I_{OH} = -400\text{ }\mu\text{A}$ $I_{OH} = -150\text{ }\mu\text{A}$ $I_{OH} = -40\text{ }\mu\text{A}$ ; note 6	2.4 $0.75V_{DD}$ $0.9V_{DD}$	– – –	V V V

## 8-bit microcontroller with on-chip CAN

## P8xC592

SYMBOL	PARAMETER	CONDITIONS	MIN.	MAX.	UNIT
V <sub>OH2</sub>	HIGH level output voltage RST	I <sub>OH</sub> = -400 μA	2.4	-	V
		I <sub>OH</sub> = -120 μA	0.8V <sub>DD</sub>	-	V
R <sub>RST</sub>	RST pull-down resistor		50	150	kΩ
C <sub>I/O</sub>	I/O pin capacitance	test frequency = 1 MHz; T <sub>amb</sub> = 25 °C	-	10	pF
<b>Supply (analog part)</b>					
AV <sub>DD</sub>	supply voltage	AV <sub>DD</sub> = V <sub>DD</sub> ± 0.2 V	4.5	5.5	V
AI <sub>DD</sub>	operating supply current	Port 5 = AV <sub>DD</sub> ; note 1	-	2.5	mA
AI <sub>DD(ID)</sub>	supply current Idle mode	note 2	-	2.5	mA
AI <sub>DD(IS)</sub>	supply current Idle and Sleep mode: P83C592 FHA P8xC592 xFx	note 3	-	400	μA
			-	350	μA
AI <sub>DD(PD)</sub>	supply current Power-down mode: P83C592 FHA P8xC592 xFx	note 4	-	400	μA
			-	350	μA
<b>Analog inputs</b>					
AV <sub>IN</sub>	analog input voltage		AV <sub>SS</sub> - 0.2	AV <sub>DD</sub> + 0.2	V
AV <sub>REF-</sub>	reference voltage		AV <sub>SS</sub> - 0.2	-	V
AV <sub>REF+</sub>			-	AV <sub>DD</sub> + 0.2	V
R <sub>REF</sub>	resistance between AV <sub>REF+</sub> and AV <sub>REF-</sub>		10	50	kΩ
C <sub>IA</sub>	analog input capacitance		-	15	pF
t <sub>ADS</sub>	sampling time	note 7	-	8t <sub>CY</sub>	μs
t <sub>ADC</sub>	conversion time (including sample time)	note 7	-	50t <sub>CY</sub>	μs
DL <sub>e</sub>	differential non-linearity	notes 8, 9 and 10	-	±1	LSB
IL <sub>e</sub>	integral non-linearity	notes 8 and 11	-	±2	LSB
OS <sub>e</sub>	offset error	notes 8 and 12	-	±2	LSB
G <sub>e</sub>	gain error	notes 8 and 13	-	±0.4	%
A <sub>e</sub>	absolute voltage error	notes 8 and 14	-	±3	LSB
M <sub>ctc</sub>	channel to channel matching		-	±1	LSB
C <sub>t</sub>	crosstalk between P5 inputs	0 to 100 kHz	-	-60	dB
<b>CAN input comparator (CRX0, CRX1)</b>					
V <sub>DIF</sub>	differential input voltage (note 15)	AV <sub>DD</sub> = 5 V ± 5%; 1.4 V < V <sub>I</sub> < AV <sub>DD</sub> -1.4 V	±32	-	mV
V <sub>HYST</sub>	hysteresis voltage (note 15)		8	30	mV
I <sub>I</sub>	input current		-	±400	nA



## 8-bit microcontroller with on-chip CAN

## P8xC592

SYMBOL	PARAMETER	CONDITIONS	MIN.	MAX.	UNIT
<b>CAN output driver (<math>V_{DD} = 5\text{ V} \pm 5\%</math>)</b>					
V <sub>OLT</sub>	LOW level output voltage (CTX0 and CTX1)	I <sub>o</sub> = 1.2 mA; note 15	–	0.1	V
		I <sub>o</sub> = 10 mA	–	0.6	V
V <sub>OHT</sub>	High level output voltage (CTX0 and CTX1)	I <sub>o</sub> = –1.2 mA; note 15	V <sub>DD</sub> – 0.1	–	V
		I <sub>o</sub> = –10 mA; note 16	V <sub>DD</sub> – 0.6	–	V
<b>Reference (<math>AV_{DD} = 5\text{ V} \pm 5\%</math>)</b>					
V <sub>REFOUT</sub>	REF output voltage	–0.1 mA < I <sub>L</sub> < 0.1 mA; C <sub>L</sub> = 10 nF; note 15; bit Reference Active = HIGH	$\frac{1}{2}AV_{DD}-0.1$	$\frac{1}{2}AV_{DD}+0.1$	V
I <sub>REFIN</sub>	REF input current	1.5 V < V <sub>REFIN</sub> < AV <sub>DD</sub> –1.5 V; bit Reference Active = LOW	–	±10	µA

**Notes to the DC characteristics**

## 1. Conditions for:

- The **digital** operating current measurement: all output pins disconnected; XTAL1 is driven with  $t_r = t_f = 10\text{ ns}$ ;  $V_{IL} = V_{SS} + 0.5\text{ V}$ ;  $V_{IH} = V_{DD} - 0.5\text{ V}$ ;  $\overline{EA} = \text{RST} = \text{Port } 0 = \text{P1.6} = \text{P1.7} = \overline{EW} = V_{DD}$ ;  $\text{STADC} = V_{SS}$ ;  $\text{CRX0} = 2.7\text{ V}$ ;  $\text{CRX1} = 2.3\text{ V}$ .
- The **analog** operating current measurement: Port 5 = AV<sub>DD</sub>; CAN: register 6: = 00H; load current reference voltage source 100 µA.

## 2. Conditions for:

- The **digital** Idle mode supply current measurement: all output pins disconnected; XTAL1 is driven with  $t_r = t_f = 10\text{ ns}$ ;  $V_{IL} = V_{SS} + 0.5\text{ V}$ ;  $V_{IH} = V_{DD} - 0.5\text{ V}$ ; Port 0 = P1.6 = P1.7 =  $\overline{EW} = V_{DD}$ ;  $\overline{EA} = \text{RST} = \text{STADC} = V_{SS}$ ;  $\text{CRX0} = 2.7\text{ V}$ ;  $\text{CRX1} = 2.3\text{ V}$ .
- The **analog** Idle mode current measurement: Port 5 = AV<sub>DD</sub>; CAN: register 6: = 00H; load current reference voltage source 100 µA.

## 3. Conditions for:

- The **digital** Idle and Sleep mode supply current measurement: all output pins disconnected; XTAL1 is driven with  $t_r = t_f = 10\text{ ns}$ ;  $V_{IL} = V_{SS} + 0.5\text{ V}$ ;  $V_{IH} = V_{DD} - 0.5\text{ V}$ ; Port 0 = P1.6 = P1.7 =  $\overline{EW} = \text{CRX0} = V_{DD}$ ;  $\overline{EA} = \text{RST} = \text{STADC} = \text{CRX1} = V_{SS}$ ; CAN: register 6: = 00H, register 7: = 12H, register 8: = 02H, register 0: = 20H, wait 15t<sub>CY</sub>, register 1: = 10H, wait for bit Sleep = 1.
- The **analog** Idle and Sleep mode current measurement: Port 5 = AV<sub>DD</sub>; load current reference voltage source 100 µA.

## 4. Window devices have to be covered. Conditions for:

- The **digital** Power-down mode supply current measurement: all output pins and Port 5 disconnected; Port 0 = P1.6 = P1.7 =  $\overline{EW} = \text{CRX0} = V_{DD}$ ;  $\overline{EA} = \text{RST} = \text{STADC} = \text{CRX1} = \text{XTAL1} = AV_{\text{REF}+} = AV_{\text{REF}-} = CV_{SS} = V_{SS}$ ;  $AV_{DD} = V_{DD}$ , but current into AV<sub>DD</sub> pin is not comprised in digital Power-down current.
- The **analog** Power-down mode supply current measurement: Port 5 = AV<sub>DD</sub>.

## 5. Capacitive loads on Port 0 and Port 2 may degrade the LOW level output voltage of ALE, Port 1 and Port 3.

During a HIGH-to-LOW transition on the Port 0 and Port 2 pins and a capacitive load >100 pF, the ALE LOW level may exceed 0.8 V. In the case that it is necessary to connect ALE to a Schmitt trigger input respectively use an address latch with a Schmitt trigger STROBE input.

## 8-bit microcontroller with on-chip CAN

## P8xC592

6. Capacitive loads on Port 0 and Port 2 may cause a HIGH level voltage degradation of ALE and  $\overline{\text{PSEN}}$  below  $0.9V_{\text{DD}}$  during the address bits are stabilizing.
7.  $t_{\text{CY}} = 12 t_{\text{CLK}}$  is the machine cycle time.
8.  $AV_{\text{REF+}} = 5.12 \text{ V}$ ;  $AV_{\text{REF-}} = 0 \text{ V}$ ;  $AV_{\text{DD}} = 5.0 \text{ V}$ .
9. The differential non-linearity ( $DL_e$ ) is the difference between the actual step width and the ideal step width.
10. The ADC is monotonic, there are no missing codes.
11. The integral non-linearity ( $IL_e$ ) is the peak difference between the centre of the steps of the actual and the ideal transfer curve after appropriate adjustment of gain and offset error.
12. The offset error ( $OS_e$ ) is the absolute difference between the straight line which fits the actual transfer curve after removing gain error, and a straight line which fits the ideal transfer curve. The offset error is constant at every point of the actual transfer curve.
13. The gain error ( $G_e$ ) is relative difference in percent between the straight line fitting the actual transfer curve after removing offset error and the straight line which fits the ideal transfer curve. The gain error is constant at every point on the transfer curve.
14. The absolute voltage error ( $A_e$ ) is the maximum difference between the centre of the steps of the actual transfer curve of the not calibrated ADC and the ideal transfer curve.
15. Not tested during production.
16. Source current for the CTX0, CTX1 outputs together.

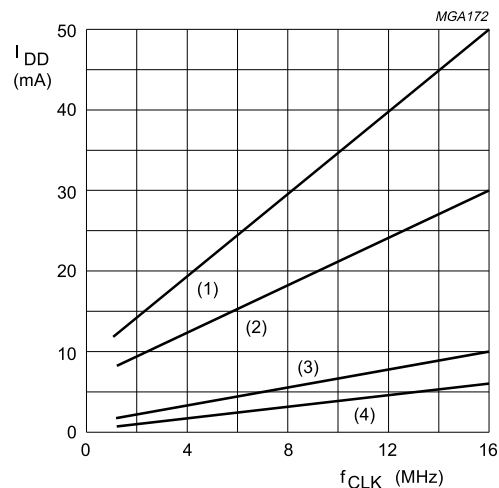

- (1) Maximum Operating mode ( $I_{\text{DD}}$ );  $V_{\text{DD}} = 5.5 \text{ V}$
- (2) Maximum Operating mode ( $I_{\text{DD}}$ );  $V_{\text{DD}} = 4.5 \text{ V}$
- (3) Maximum Idle and Sleep mode ( $I_{\text{DD(IS)}}$ );  $V_{\text{DD}} = 5.5 \text{ V}$
- (4) Maximum Idle and Sleep mode ( $I_{\text{DD(IS)}}$ );  $V_{\text{DD}} = 4.5 \text{ V}$

Fig.27 Supply current ( $I_{\text{DD}}$ ) as a function of frequency at XTAL1 ( $f_{\text{CLK}}$ ).

8-bit microcontroller with on-chip CAN

P8xC592

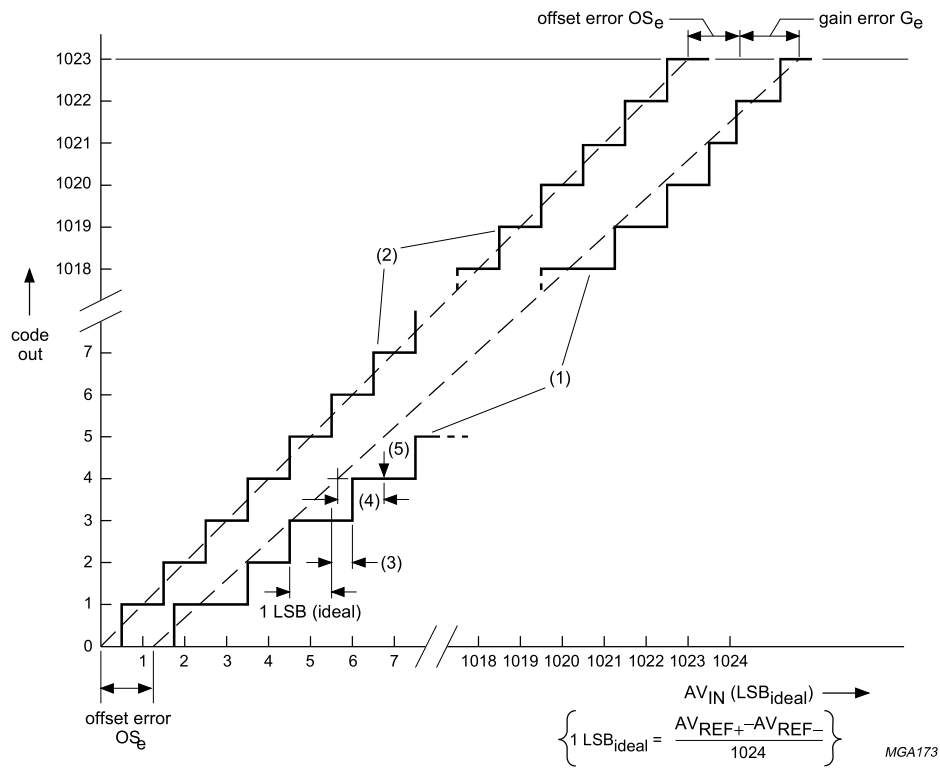

- (1) Example of an actual transfer curve.
- (2) The ideal transfer curve.
- (3) Differential non-linearity (DL<sub>e</sub>).
- (4) Integral non-linearity (IL<sub>e</sub>).
- (5) Centre of a step of the actual transfer curve.

Fig.28 ADC conversion characteristic.

## 8-bit microcontroller with on-chip CAN

## P8xC592

## 21 AC CHARACTERISTICS

See notes 1 and 2;  $C_L = 100$  pF for Port 0, ALE and  $\overline{\text{PSEN}}$ ;  $C_L = 80$  pF for all other outputs unless otherwise specified.

SYMBOL	PARAMETER	$f_{\text{CLK}} = 16$ MHz		$f_{\text{CLK}} = 12$ MHz		VARIABLE CLOCK 1.2 to 16 MHz		UNIT
		MIN.	MAX.	MIN.	MAX.	MIN.	MAX.	
<b>External Program Memory</b>								
$t_{\text{LHLL}}$	ALE pulse width	85	–	127	–	$2t_{\text{CLK}} - 40$	–	ns
$t_{\text{AVLL}}$	address valid to ALE LOW	23	–	43	–	$t_{\text{CLK}} - 40$	–	ns
$t_{\text{LLAX}}$	address hold after ALE LOW	33	–	53	–	$t_{\text{CLK}} - 30$	–	ns
$t_{\text{LLIV}}$	ALE LOW to valid instruction in	–	150	–	233	–	$4t_{\text{CLK}} - 100$	ns
$t_{\text{LLPL}}$	ALE LOW to $\overline{\text{PSEN}}$ LOW	33	–	53	–	$t_{\text{CLK}} - 30$	–	ns
$t_{\text{PLPH}}$	$\overline{\text{PSEN}}$ pulse width	143	–	205	–	$3t_{\text{CLK}} - 45$	–	ns
$t_{\text{PLIV}}$	$\overline{\text{PSEN}}$ LOW to valid instruction in	–	83	–	145	–	$3t_{\text{CLK}} - 105$	ns
$t_{\text{PXIX}}$	input instruction hold after $\overline{\text{PSEN}}$	0	–	0	–	0	–	ns
$t_{\text{PXIZ}}$	input instruction float after $\overline{\text{PSEN}}$	–	38	–	59	–	$t_{\text{CLK}} - 25$	ns
$t_{\text{AVIV}}$	address to valid instruction in	–	208	–	312	–	$5t_{\text{CLK}} - 105$	ns
$t_{\text{PLAZ}}$	$\overline{\text{PSEN}}$ LOW to address float	–	10	–	10	–	10	ns
<b>External data memory</b>								
$t_{\text{RLRH}}$	$\overline{\text{RD}}$ pulse width	275	–	400	–	$6t_{\text{CLK}} - 100$	–	ns
$t_{\text{WLWH}}$	$\overline{\text{WR}}$ pulse width	275	–	400	–	$6t_{\text{CLK}} - 100$	–	ns
$t_{\text{AVLL}}$	address valid to ALE LOW	8	–	28	–	$t_{\text{CLK}} - 55$	–	ns
$t_{\text{LLAX}}$	address hold after ALE LOW	33	–	53	–	$t_{\text{CLK}} - 30$	–	ns
$t_{\text{RLDV}}$	$\overline{\text{RD}}$ LOW to valid data in	–	148	–	252	–	$5t_{\text{CLK}} - 165$	ns
$t_{\text{RHDX}}$	data hold after $\overline{\text{RD}}$	0	–	0	–	0	–	ns
$t_{\text{RHDZ}}$	data float after $\overline{\text{RD}}$	–	55	–	97	–	$2t_{\text{CLK}} - 70$	ns
$t_{\text{LLDV}}$	ALE LOW to valid data in	–	350	–	517	–	$8t_{\text{CLK}} - 150$	ns
$t_{\text{AVDV}}$	address to valid data in	–	398	–	585	–	$9t_{\text{CLK}} - 165$	ns
$t_{\text{LLWL}}$	ALE LOW to $\overline{\text{RD}}$ or $\overline{\text{WR}}$ LOW	138	238	200	300	$3t_{\text{CLK}} - 50$	$3t_{\text{CLK}} + 50$	ns
$t_{\text{AVWL}}$	address valid to $\overline{\text{RD}}$ or $\overline{\text{WR}}$ LOW	120	–	203	–	$4t_{\text{CLK}} - 130$	–	ns
$t_{\text{WHLH}}$	$\overline{\text{RD}}$ or $\overline{\text{WR}}$ HIGH to ALE HIGH	23	103	43	123	$t_{\text{CLK}} - 40$	$t_{\text{CLK}} + 40$	ns
$t_{\text{QVWX}}$	data valid to $\overline{\text{WR}}$ transition	13	–	33	–	$t_{\text{CLK}} - 50$	–	ns
$t_{\text{QVWH}}$	data valid time $\overline{\text{WR}}$ HIGH	288	–	433	–	$7t_{\text{CLK}} - 150$	–	ns
$t_{\text{WHQX}}$	data hold after $\overline{\text{WR}}$	13	–	33	–	$t_{\text{CLK}} - 50$	–	ns
$t_{\text{RLAZ}}$	$\overline{\text{RD}}$ LOW to address float	–	0	–	0	–	0	ns

## Notes

1. For the AC Characteristics the following conditions are valid: **P8xC592 FFA (FHA)**:  $V_{\text{DD}} = 5 \text{ V} \pm 10\%$ ;  
 $T_{\text{amb}} = -40$  to  $+85$  °C (125 °C);  $f_{\text{CLK}} = 1.2$  to 16 MHz.

2.  $t_{\text{CLK}} = \frac{1}{f_{\text{CLK}}}$  = one oscillator clock period ;  $t_{\text{CLK}} = 62.5$  ns at  $f_{\text{CLK}} = 16$  MHz.

8-bit microcontroller with on-chip CAN

P8xC592

**Table 90** CAN characteristics

SYMBOL	PARAMETER	CONDITIONS	MIN.	MAX.	UNIT
<b>CAN input comparator/output driver</b>					
$t_{sd}$	sum of input and output delay	$AV_{DD} = 5\text{ V} \pm 5\%$ ; $V_{DIF} = \pm 32\text{ mV}$ ; $1.4\text{ V} < V_I < AV_{DD} - 1.4\text{ V}$	–	60	ns

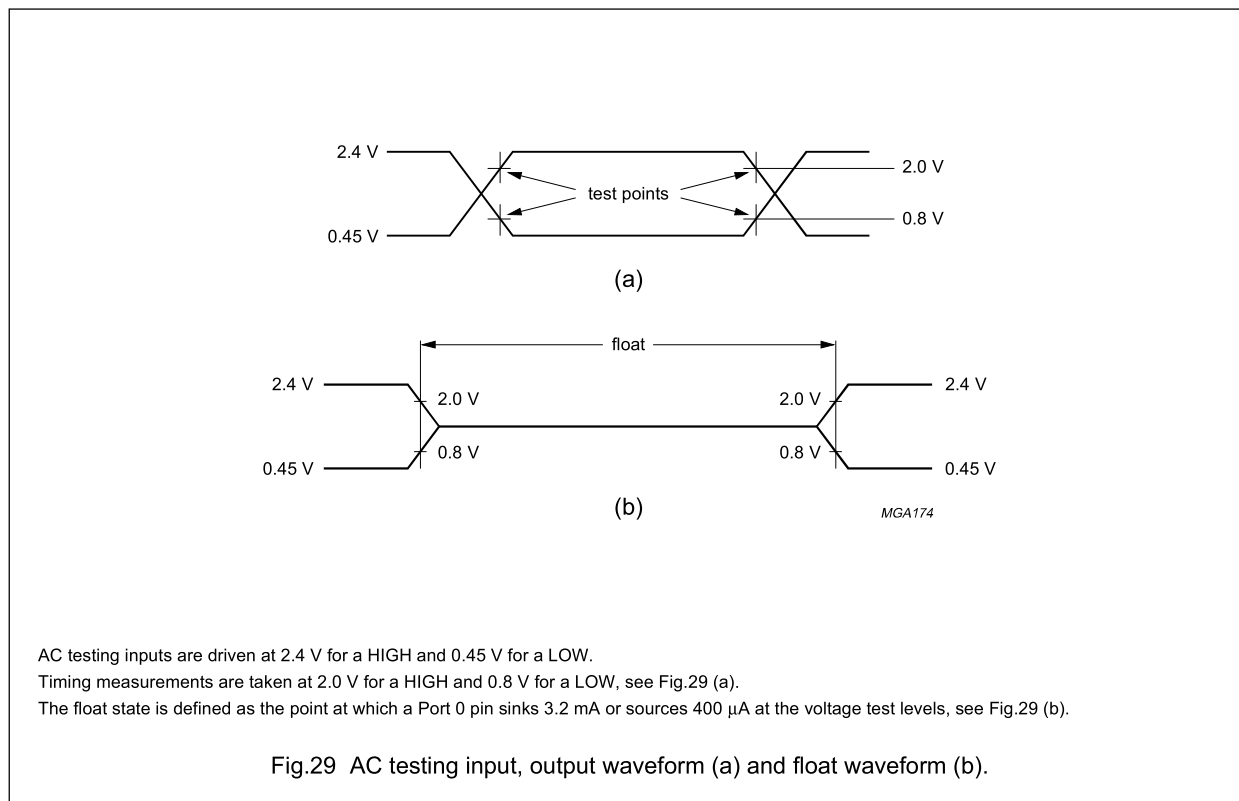
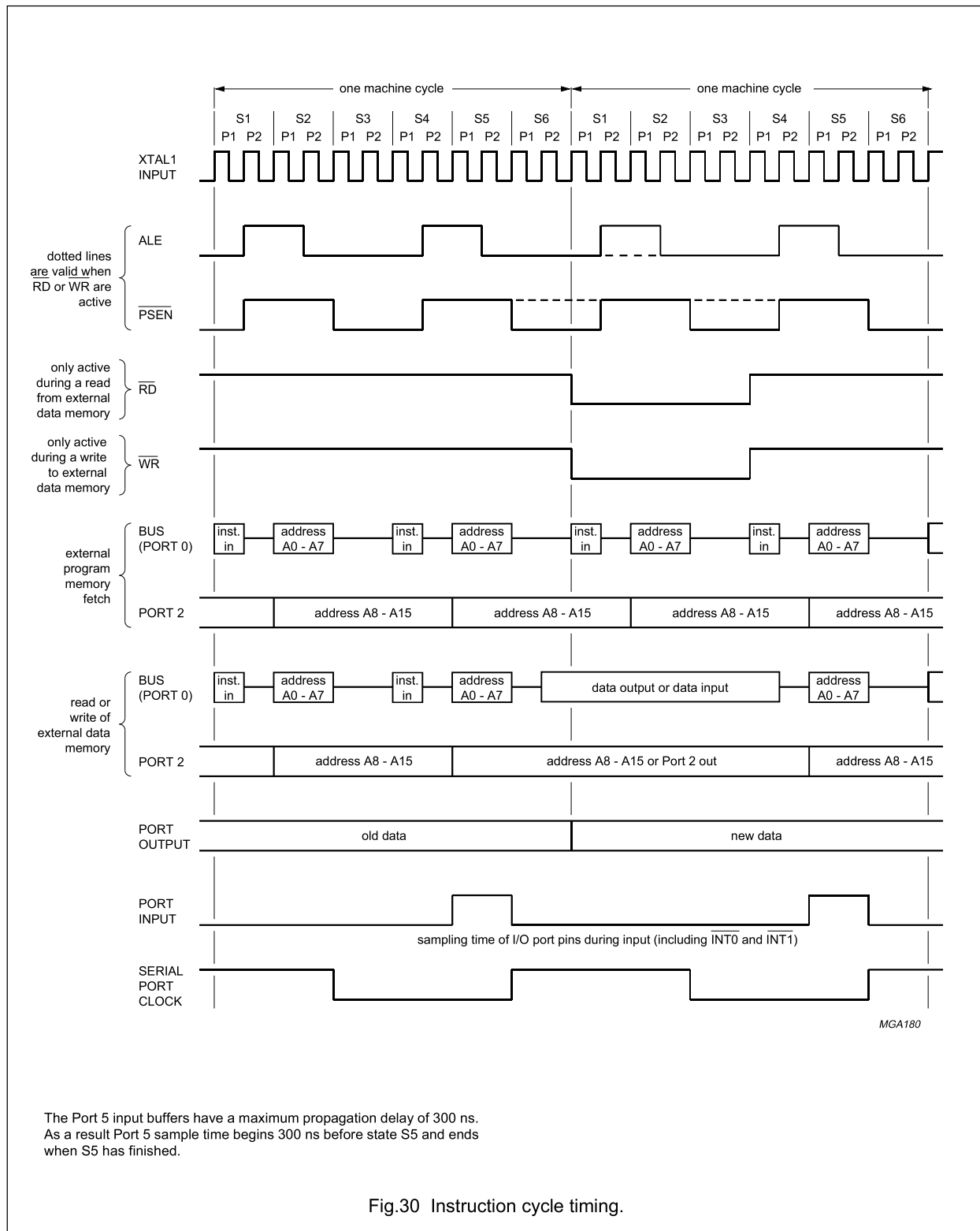

Fig.29 AC testing input, output waveform (a) and float waveform (b).

8-bit microcontroller with on-chip CAN

P8xC592



The Port 5 input buffers have a maximum propagation delay of 300 ns. As a result Port 5 sample time begins 300 ns before state S5 and ends when S5 has finished.

Fig.30 Instruction cycle timing.

8-bit microcontroller with on-chip CAN

P8xC592

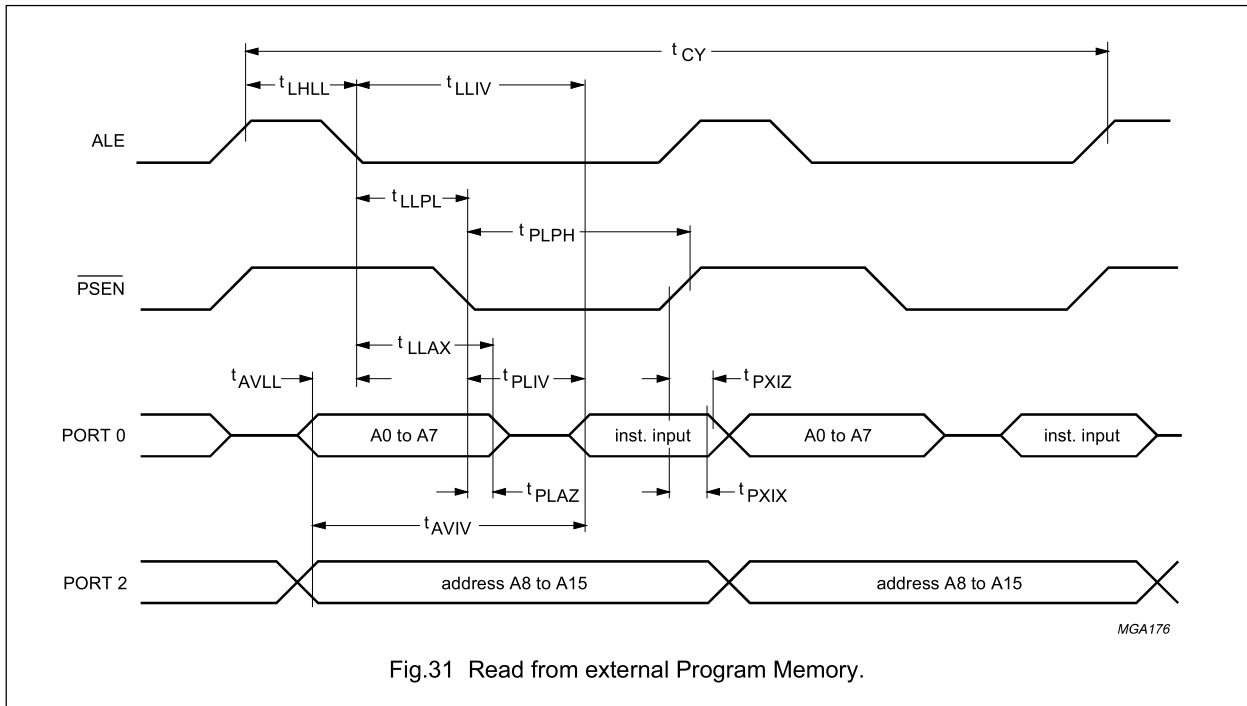

Fig.31 Read from external Program Memory.

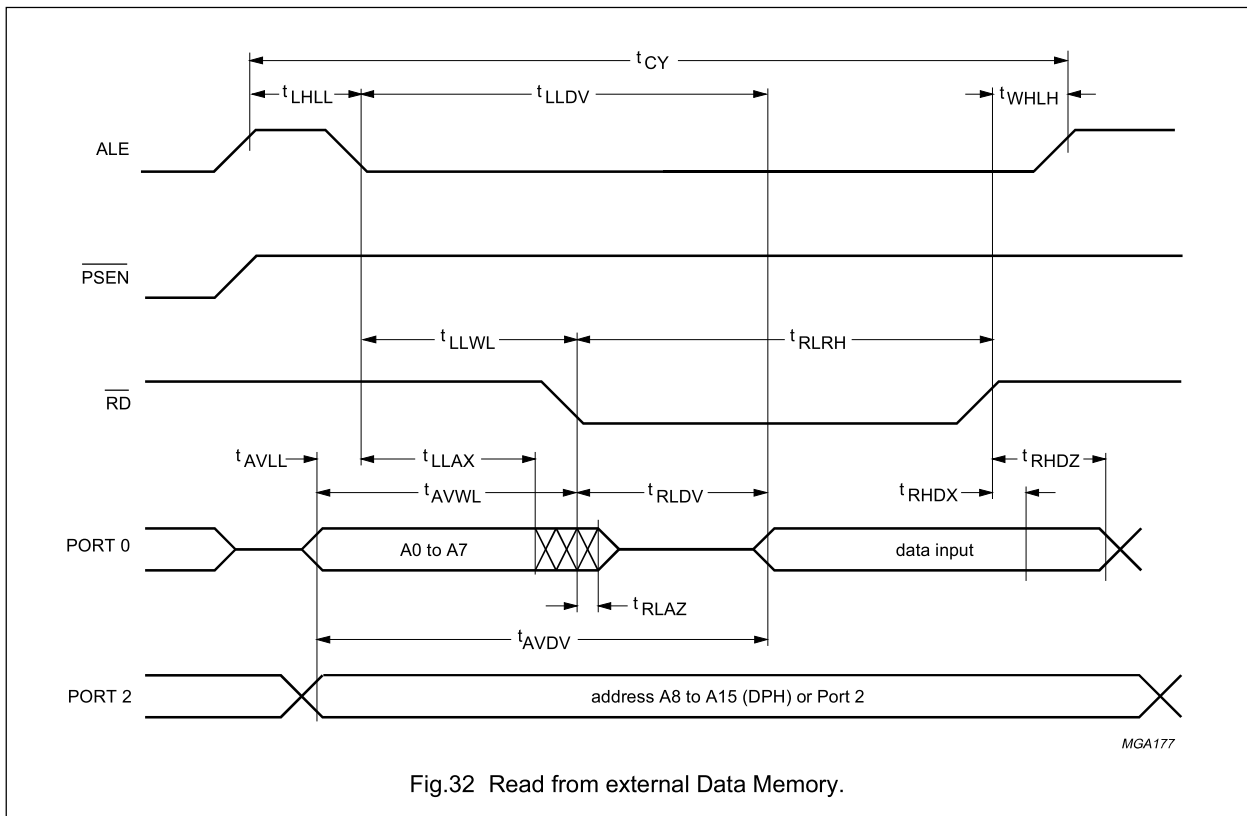

Fig.32 Read from external Data Memory.

8-bit microcontroller with on-chip CAN

P8xC592

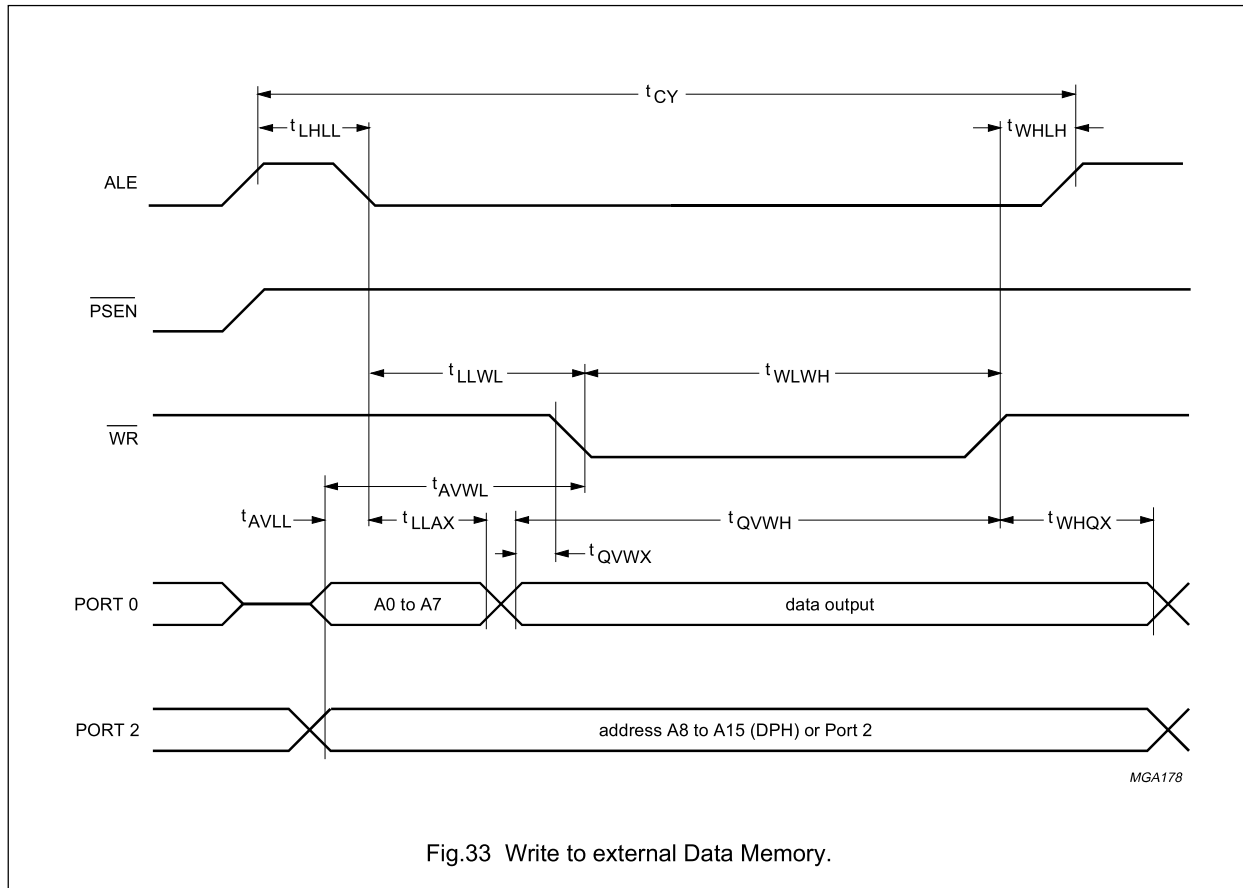

Fig.33 Write to external Data Memory.

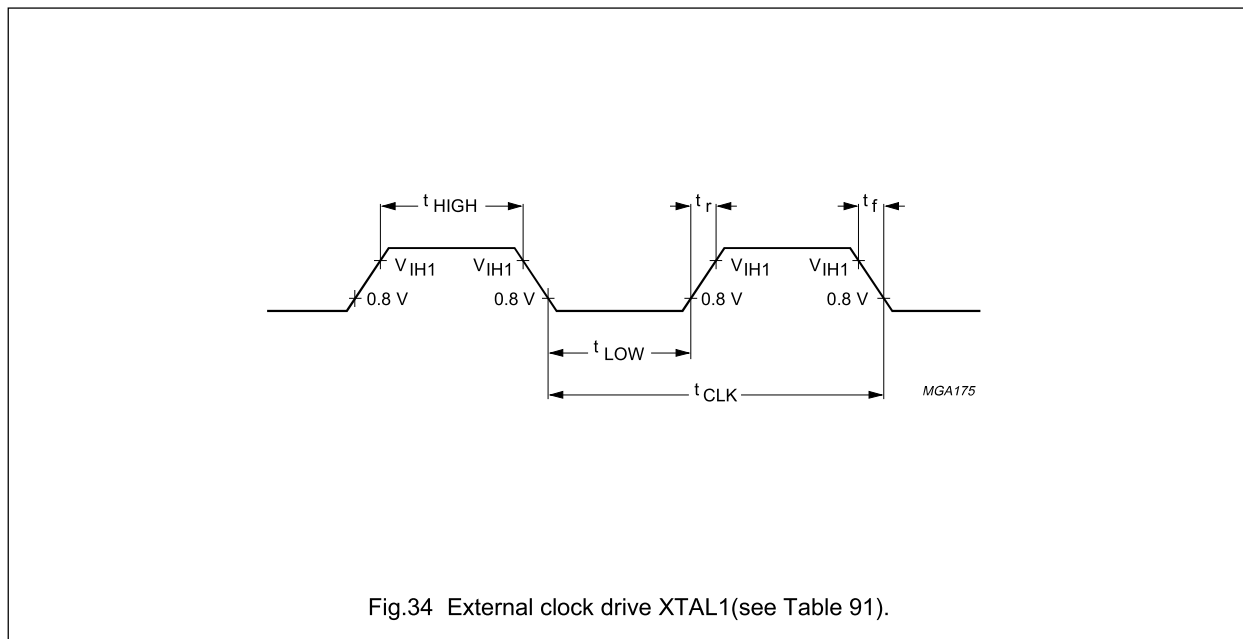

Fig.34 External clock drive XTAL1(see Table 91).



8-bit microcontroller with on-chip CAN

P8xC592

**Table 91** External clock drive XTAL1

SYMBOL	PARAMETER	VARIABLE CLOCK ( $f_{CLK} = 1.2$ to $16$ MHz)		UNIT
		MIN.	MAX.	
$t_{CLK}$	oscillator clock period (P83C592)	62.5	833.3	ns
$t_{HIGH}$	HIGH time	20	$t_{CLK} - t_{LOW}$	ns
$t_{LOW}$	LOW time	20	$t_{CLK} - t_{HIGH}$	ns
$t_r$	rise time	–	20	ns
$t_f$	fall time	–	20	ns
$t_{CY}$	cycle time ( $12 \times t_{CLK}$ )	0.75	10	$\mu s$

**Table 92** UART Timing in Shift Register Mode

SYMBOL	PARAMETER	$f_{CLK}$						UNIT
		16 MHz		12 MHz		VARIABLE CLOCK		
		MIN.	MAX.	MIN.	MAX.	MIN.	MAX.	
$t_{XLXL}$	Serial Port clock cycle timing	0.75	–	1.0	–	$12t_{CLK}$	–	ms
$t_{QVXH}$	output data setup to clock rising edge	492	–	700	–	$10t_{CLK} - 133$	–	ns
$t_{XHQX}$	output data hold after clock rising edge	8.0	–	50	–	$2t_{CLK} - 117$	–	ns
$t_{XHDX}$	input data hold after clock rising edge	0	–	0	–	0	–	ns
$t_{XHDV}$	clock rising edge to input data valid	–	492	–	700	–	$10t_{CLK} - 133$	ns

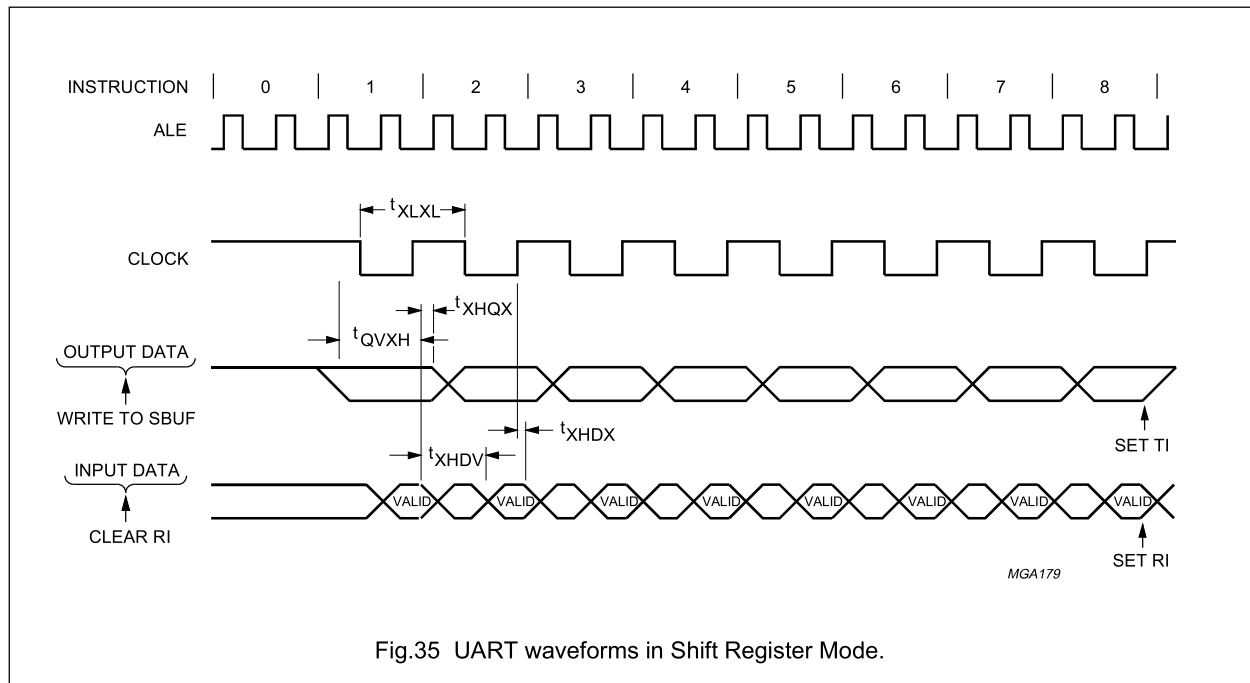

Fig.35 UART waveforms in Shift Register Mode.

## 8-bit microcontroller with on-chip CAN

## P8xC592

**22 CAN APPLICATION INFORMATION****22.1 Latency time requirements**

Real-time applications require the ability to process and transfer information in a limited and predetermined period of time. If knowing this total time and the time required to process the information, the (maximum allowed) transfer delay time is given.

It is measured from the initiation of the transfer up to the signalling of reception.

For instance, this is the period of time between programming the CAN Command Register bit 0 (Transmission Request) to HIGH and the time getting an interrupt at a receiving CAN-device (due to the reception of the respective message).

**22.1.1 MAXIMUM ALLOWED BIT-TIME CALCULATION**

The maximum allowed bit-time ( $t_{\text{BIT}}$ ) due to latency time requirements can be calculated as:

$$t_{\text{BIT}} \leq \frac{t_{\text{MAX TRANSFER TIME}}}{(n_{\text{BIT, MAX LATENCY}} + n_{\text{BIT, MESSAGE}})} \quad (1)$$

Where:

- $t_{\text{MAX TRANSFER TIME}}$ :  
the maximum allowed transfer delay time (application-specific).
- $n_{\text{BIT, MAX LATENCY}}$ :  
the maximum latency time (in terms of number of bits), which depends on the actual state of the CAN network (e.g. another message already on the network);
- $n_{\text{BIT, MESSAGE}}$ :  
the number of bits of a message; it varies with the number of transferred data bytes  $n_{\text{DATA BYTES}}$  (0..8) and Stuffbits like:

$$44 + 8.n_{\text{DATA BYTES}} \leq n_{\text{BIT, MESSAGE}} \leq 52 + 10.n_{\text{DATA BYTES}} \quad (2)$$

Example:

For the calculation of  $n_{\text{BIT, MAX LATENCY}}$  the following is assumed (the term 'our message' refers to that one the latency time is calculated for):

- since at maximum one-bit-time ago another CAN-controller is transmitting.
- a single error occurs during the transmission of that message preceding ours, leading to the additional transfer of one Error Frame
- 'our message' has the highest priority,

giving:

$$n_{\text{BIT, MAX LATENCY}} \geq 44 + 8.n_{\text{DATA BYTES, WORST CASE}} + 18 \quad (3)$$

$$n_{\text{BIT, MAX LATENCY}} \leq 52 + 10.n_{\text{DATA BYTES, WORST CASE}} + 18 \quad (4)$$

Where:

- The additional 18 bits are due to the Error Frame and the Intermission Field preceding 'our message'.
- $n_{\text{DATA BYTES, WORST CASE}}$  denotes the number of data bytes contained by the longest message being used in a given CAN network.

## 8-bit microcontroller with on-chip CAN

## P8xC592

## 22.1.2 CALCULATING THE MAXIMUM BIT-TIME

**Table 93** Example for calculating the maximum bit-time

STATEMENT	COMMENTS
$t_{\text{MAX TRANSFER TIME}} = 10 \text{ ms}$	assumption
$n_{\text{DATA BYTES, WORST CASE}} = 6$	longest message in that network; assumption
$n_{\text{DATA BYTES}} = 4$	'our message'; assumption
$n_{\text{BIT MAX LATENCY}} \leq 130$	using Equation (3) and (4)
$n_{\text{MESSAGE}} \leq 92$	using Equation (2)
$t_{\text{BIT}} \leq \frac{10 \text{ ms}}{(130 + 92)} = 0.045 \text{ ms} = 45 \mu\text{s}$	using Equation (1)

## 22.2 Connecting a P8xC592 to a bus line (physical layer)

### 22.2.1 ON-CHIP TRANSCEIVER

The P8xC592 features an on-chip differential transceiver including output driver and input comparator both being configurable (see Fig.36). Therefore it supports many types of common transmission media such as:

- Single-wire bus line
- Two-wire bus line (differential)
- Optical cable bus line.

The P8xC592 can directly drive a differential bus line. An example is given in Fig.37 for a bus line having a characteristic impedance of 120  $\Omega$ . Direct interfacing to the bus line is well suited for applications with limited requirements concerning electromagnetic susceptibility, wiring failure tolerance and protection against transients.

### 22.2.2 TRANSCEIVER FOR IN-VEHICLE COMMUNICATION

Fig.38 shows a versatile transceiver implementation designed for automotive applications. It features a bit rate of up to 1 Mbit/s and dissipates low power during standby (1.4 mA). Thus it is suitable also for applications requiring a Sleep mode function with system activation via the bus line. The transceiver provides an extended common mode range for high electromagnetic susceptibility performance.

Two external driver transistors amplify the output current to 35 mA typically and provide protection against overvoltage conditions on the bus line (e.g. due to an accidental short-circuit between a bus wire and battery voltage). The serial diodes prevent in combination with the transistors the bus from being blocked in case of a bus not powered. More than 32 nodes may be connected to the bus line.

### 22.2.3 DETECTION AND HANDLING OF BUS WIRING FAILURES

Using the P8xC592 a superior wiring failure tolerance and detection performance can be achieved. This requires both bus lines to be mutually decoupled as shown in Fig.39. Each bus wire is biased separately to a reference voltage of  $\frac{1}{2}AV_{DD}$ .

The diodes suppress reverse current in case of a termination circuit being not properly powered or a bus line being short i.e. to a voltage higher than 5 V. Applying this bus termination circuit the following wiring failures on the bus are detectable and can be handled:

- Interruption of one bus wire at any location.
- Short-circuit of one bus wire to ground or battery voltage.
- Short-circuit between the bus wires.

A bus failure can be detected e.g. by a drop out of a status message, regularly being transmitted on the bus. If a bus wire is corrupted the following actions have to be taken:

- Switch the corresponding comparator input over to a reference voltage of  $\frac{1}{2}AV_{DD}$ .
- Disable the corresponding output driver stage.

As a consequence communication will continue on that bus wire not being corrupted. The required reference voltage and the switches for the comparator inputs are provided on-chip. An output driver stage can be disabled by reconfiguration of the on-chip output driver (reprogramming of the Output Control Register of the P8xC592; see Section 13.5.11, Table 51). To find out which of the bus wires is corrupted a heuristic method is applied.

8-bit microcontroller with on-chip CAN

P8xC592

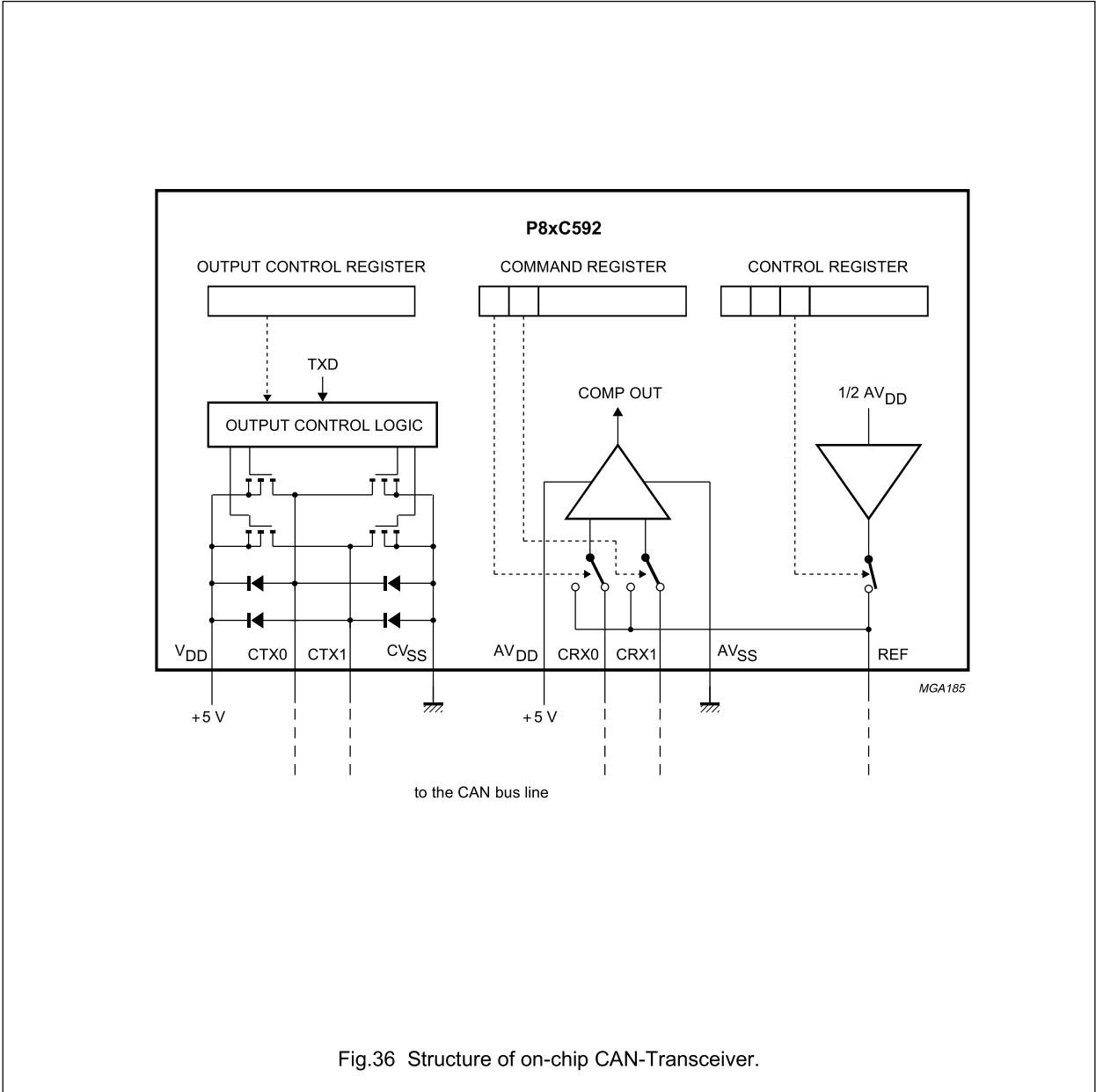

Fig.36 Structure of on-chip CAN-Transceiver.

8-bit microcontroller with on-chip CAN

P8xC592

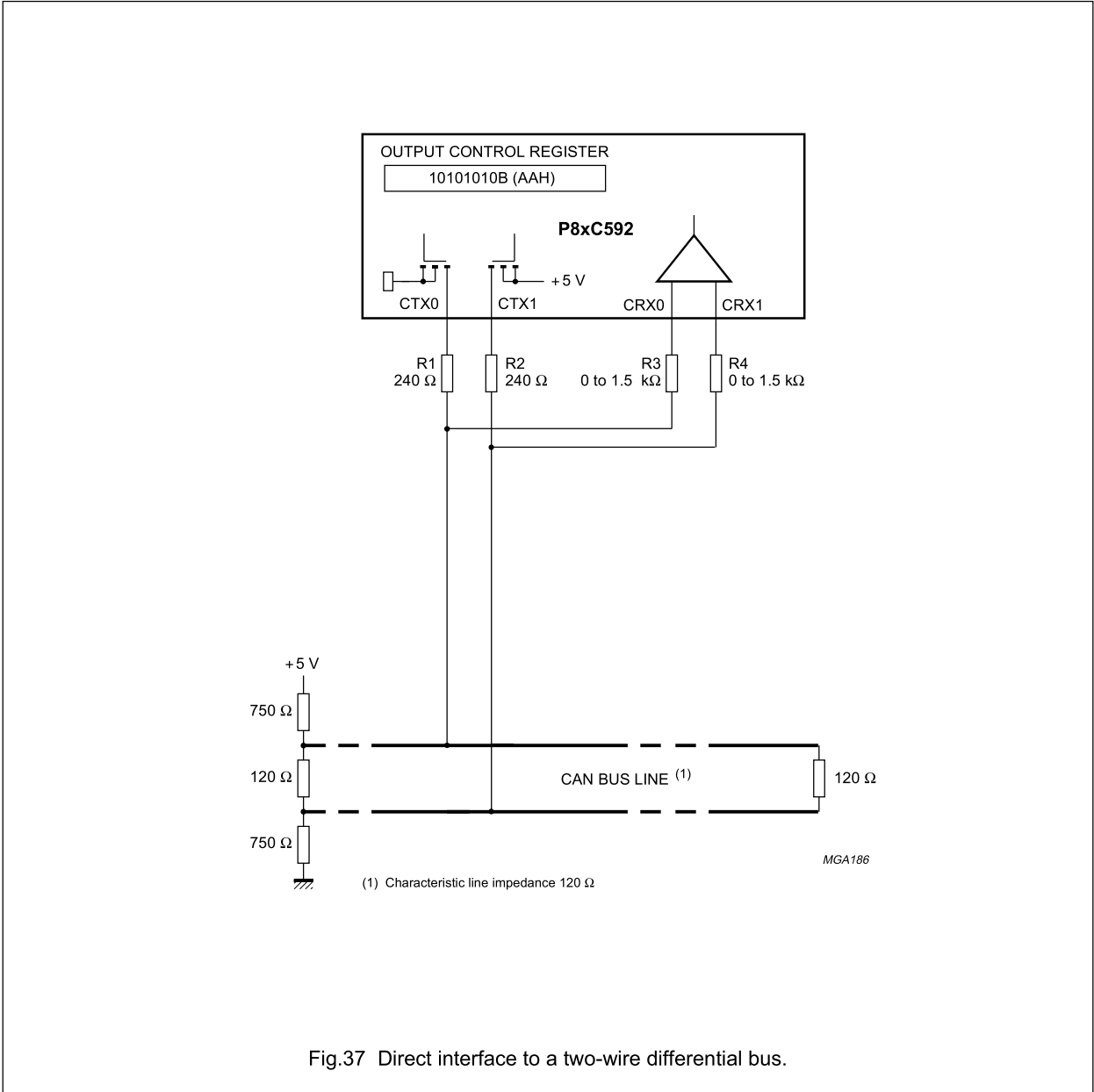

Fig.37 Direct interface to a two-wire differential bus.

8-bit microcontroller with on-chip CAN

P8xC592

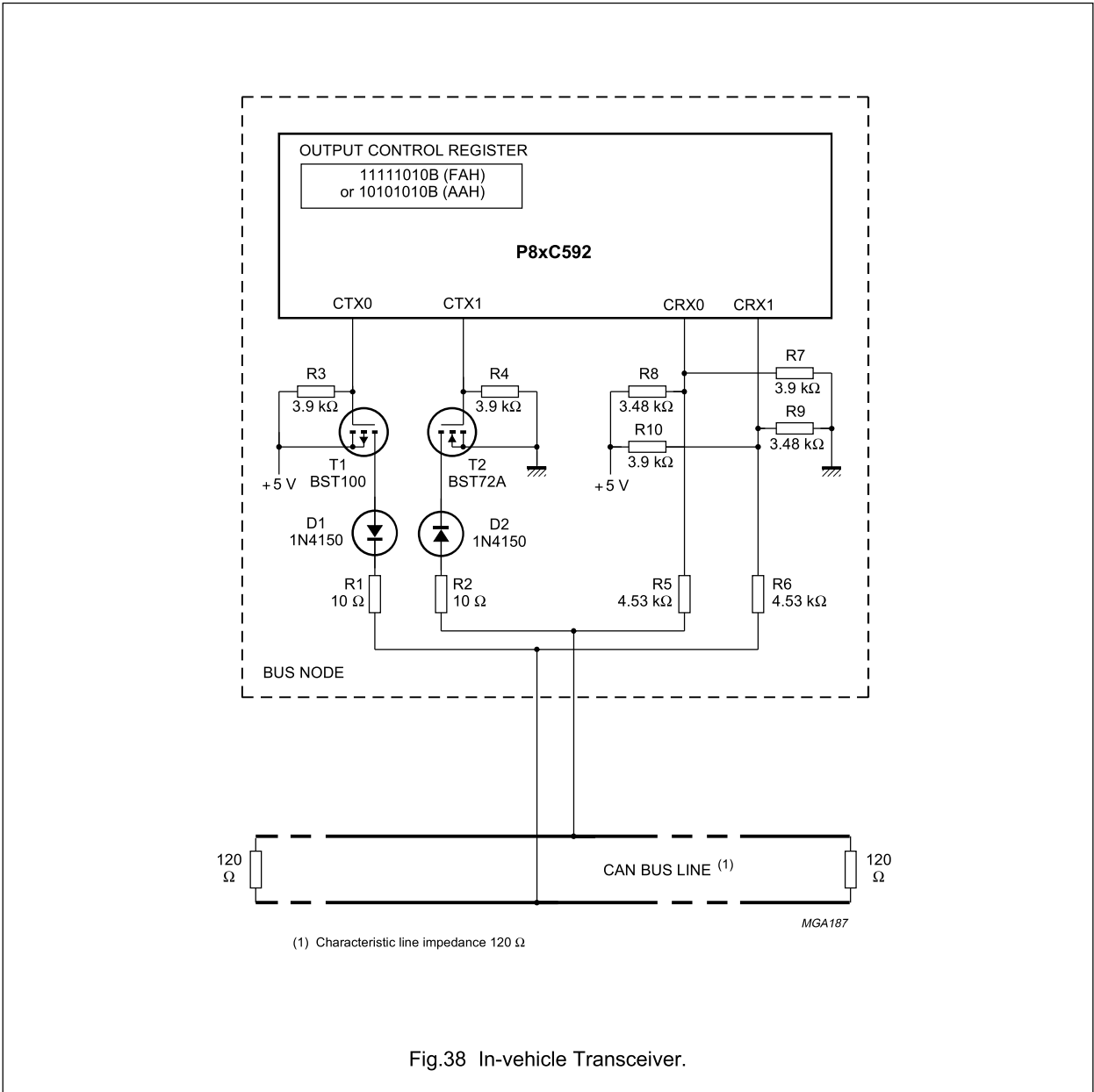

Fig.38 In-vehicle Transceiver.

8-bit microcontroller with on-chip CAN

P8xC592

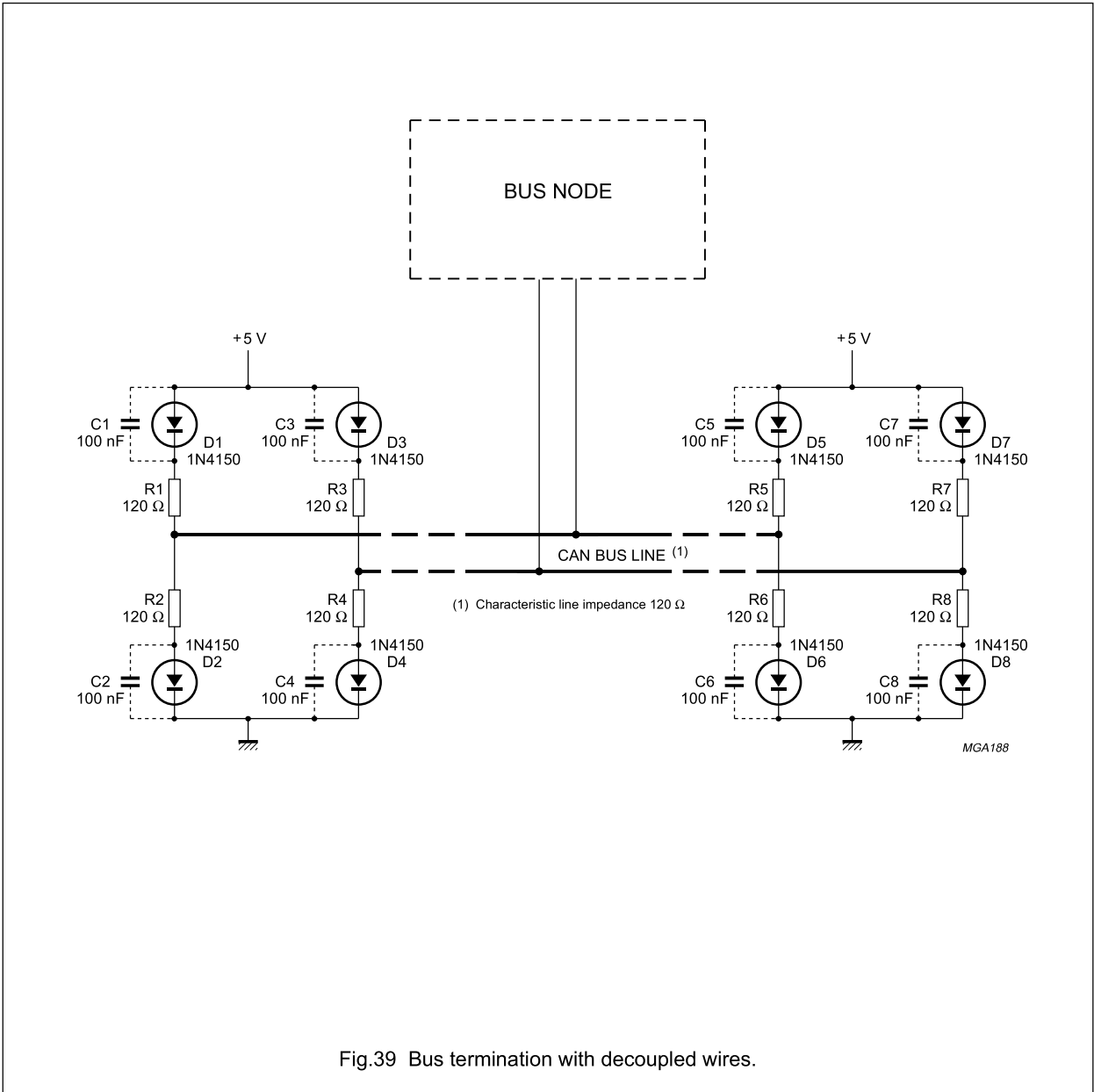

Fig.39 Bus termination with decoupled wires.

# 8-bit microcontroller with on-chip CAN

# P8xC592

## 22.2.4 CONNECTION TO AN OPTICAL BUS LINE

Using an optical medium provides the following advantages:

- Bus nodes are galvanically decoupled.
- Optical cable features very high noise immunity.
- No noise emission by the bus cable.

An example for an interface to an optical connector is given in Fig.40. In most cases a transistor is required to amplify the TX-output current.

Thus more optical power is provided to compensate for losses in the optical connectors and the optical star. The P8xC592 features an on-chip  $\frac{1}{2}AV_{DD}$  reference voltage output so only a capacitor is required for the receiver part. Two optical fibres are used to connect the bus nodes. The TX-fibre transfers the output signal of the CAN-controller to the optical star. The optical star transfers the TX-fibre input signal over to all the RX-fibres. The RX-fibres transfer the resulting optical signal over to the receivers of all the bus nodes.

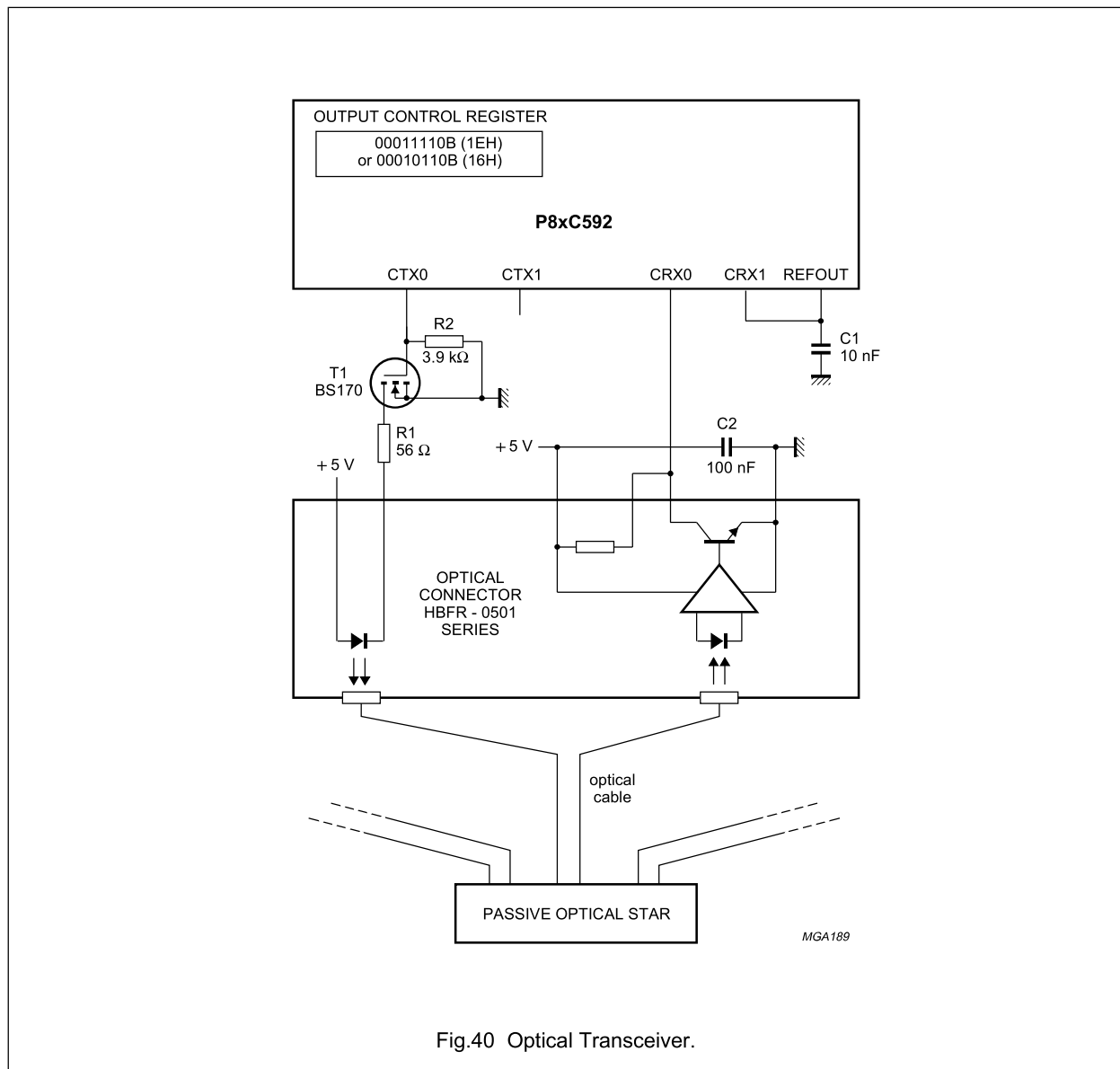

Fig.40 Optical Transceiver.



## 8-bit microcontroller with on-chip CAN

P8xC592

## 22.2.5 P8xC592 CAN INTERRUPT HANDLER SOFTWARE EXAMPLE (INCLUDING FAST DMA TRANSFER).

**MCS-51 MACRO ASSEMBLER P8xC592 CAN interrupt-handler**

LOC	OBJ	LINE	SOURCE
		1	\$TITLE (8xC592 CAN interrupt-handler)
00A0		2	\$NOSYMBOLS NOPAGING
00A1		3	
		4	*****
		5	;
		6	;Very fast receive-routine for the 8xC592. It:
		7	• is embedded in the interrupt-handler for the CAN-controller,
		8	• uses the DMA-logic and
		9	• handles up to eight different messages
00A2		10	;(if these have the same leading 8 identifier-bits).
		11	;
		12	;To allow for faster receive-routine, it is assumed that all other routines
		13	;accessing the CAN-controller, disable the interrupt of the CAN-controller
		14	;(IEN0.5) during their execution.
00A5		15	;
00A7		16	;Version: 1.0
		17	;Date: 12-April-90
		18	;Author: Bernhard Reckels
		19	;at: Philips Components Application Lab., Hamburg (PCALH)
00A9		20	
00AB		21	*****
00AD		22	;
		23	*****
		24	;initial stuff
		25	*****
		26	;
		27	;equatas
		28	
		29	;addresses of Special Function Registers
00AE		30	CANADR EQU 0DBH
00AF		31	CANDAT EQU 0DAH
		32	CANCON EQU 0D9H
00B0		33	CANSTA EQU 0D8H
		34	

## 8-bit microcontroller with on-chip CAN

P8xC592

LOC	OBJ	LINE	SOURCE
		35	;commands for the CAN-controller / DMA logic
		36	CAN_REF_REL EQU 0000100B ;Release Receive Buffer
00A0		37	CAN_RX_DMA EQU 80H + 22 ;Rx DMA-transfer
00A1		38	
		39	; addresses of CAN-controller internal registers
		40	CAN_REF EQU 20 ;1st address of Rx-buffer
		41	
		42	; masks
		43	INT_FLAG_MASK EQU 00011111B ;all CAN's interrupt-flags
		44	ID2_0_MASK EQU 11100000B ;only ID.2 ... ID.0 bits
00A2		45	; jump-address for a CAN-controller interrupt
		46	
		47	
		48	CSEG at 2BH
	020080	49	LJMP CAN_INT_HANDLER ; CAN's interrupt-vector
00A5		50	
00A7		51	; data storage
		52	
		53	DSEG at 20H
		54	CAN_INT_IMAGE: DS 1
00A9		55	
00AB		56	BSEG at 00H
00AD		57	CAN_INT_RX: DBIT 1 ; = CAN_INT_IMAGE.0
		58	CAN_INT_TX: DBIT 1 ; = CAN_INT_IMAGE.1
		59	CAN_INT_KR: DBIT 1 ; = CAN_INT_IMAGE.2
		60	CAN_INT_OV: DBIT 1 ; = CAN_INT_IMAGE.3
		61	CAN_INT_WK: DBIT 1 ; = CAN_INT_IMAGE.4
		62	
		63	.*****
		64	;CAN-controller interrupt-handler
00AE		65	;
00AF		66	;Only the receive-interrupt is coded.
		67	;
00B0		68	.*****
		69	
		70	CSEG at 080H
		71	

## 8-bit microcontroller with on-chip CAN

P8xC592

LOC	OBJ	LINE	SOURCE
00A0		72	CAN_INT_HANDLER:
00A1		73	
		74	; first save used registers
	C0D0	75	PUSH PSW
	C0E0	76	PUSH ACC
		77	
		78	; store the CAN-controller's Interrupt Register contents
		79	; (here: at a bit-addressable location).
00A2		80	; This is necessary because after reading the Interrupt Register
		81	; its contents is cleared, but – on the other hand – several flags
		82	; may be set in coincidence.
	E5D9	83	MOV A, CANON
	541F	84	ANL A, #INT_FLAG_MASK ; only interrupt-flags
00A5	F520	85	MOV CAN_INT_IMAGE, A
00A7		86	
		87	
		88	;dispatcher-----
		89	INT_TEST0:
00A9	10000	90	JBC CAN_INT_RX,CAN_RX_SERV ;receive-interrupt?
00AB		91	
00AD		92	INT_TEST1:
		93	; here the dispatcher has to be completed according
		94	; to the application-specific requirements
		95	; ...
		96	; ...
		97	; end of dispatcher-----
		98	
		99	;Rx-serve-----
00AE		100	; copy message (Data-Field only) from CAN- to CPU memory
00AF		101	
		102	CAN_RX_SERVE
00B0		103	; read 2nd Descriptor-Byte from the Rx-Buffer (address 21)
	75DB15	104	MOV CANADR, #CAN_REF + 1
	E5DA	105	MOV A, CANDAT
		106	

## 8-bit microcontroller with on-chip CAN

## P8xC592

LOC	OBJ	LINE	SOURCE
00A0		107	; determine the destination address in data-memory for the
00A1		108	; message's Data-Field
	54E0	109	ANL                   A, #ID2_0_MASK                   ; use ID.2 ... ID.0 only
	C4	110	SWAP                 A
	03	111	RR                   A   ; A = 4*ID.2 + 2*ID.1 + ID.0
		112	; this value is used as an index for an array of 8 bytes
		113	; containing the destination-addresses for the 8 different
		114	; messages. Note, that the #RX_ARRAY_OFFSET is due to the
00A2		115	; program counter-relative access to the array.
	2415	116	ADD                 A, #RX_ARRAY_START - RX_ARRAY_OFFSET
	83	117	MOVC                A, @A + PC
		118	RX_ARRAY_OFFSET:
		119	
00A5		120	; if a message passes the acceptance-filter of the CAN
00A7		121	; Controller, but the CPU doesn't need it, the array
		122	; entry's value may be set to zero indicating this.
		123	; The following <jz> instruction cares for this.
	6007	124	JZ                   CAN_RX_READY
00A9		125	
00AB		126	; now copy the Data-Field (only) from CAN- to CPU memory
00AD		127	; with the aid of the DMA-logic. Note, that a TX-DMA is
		128	; performed when writing 8AH (DMA + address 10) into CANADR
		129	; and a RX-DMA is performed when writing 94H (DMA + address 20)
		130	; ... 9DH (DMA + address 29) into CANADR. Here address 22 is
		131	; used to copy just the Data-Field.
	F5D8	132	MOV                 CANSTA, A                   ; data-memory address
	75DB96	133	MOV                 CANADR, #CAN_RX_DMA   ; starts RX-DMA at address 22
		134	
00AE		135	; the DMA-transfer is done in at maximum 2 instruction cycles.
00AF		136	; During the transfer, neither the data-memory (RAM) nor one
		137	; of the SFRs CANADR, CANDAT, CANCON and
00B0		138	; CANSTA may be accessed by the CPU.
		139	; For simplicity, two NOPs are used here.
	00	140	NOP
	00	141	NOP
00A0		142	

## 8-bit microcontroller with on-chip CAN

P8xC592

LOC	OBJ	LINE	SOURCE
00A1		143	; after reading the Rx-Buffer it must be released back to
		144	; the CAN-controller. In coincidence, the Clear Overrun bit
		145	; (CANCON.3) may be set, regardless of an existing or
		146	; non-existing data overrun.
		147	CAN_RX_READY:
	75D904	148	MOV CANCON, #CAN_RBF_REL
		149	
00A2		150	; if no other interrupt-flag is set, the interrupt-handler
		151	; for the CAN-controller can be left. Otherwise further
		152	; services are required.
	E520	153	MOV A, CAN_INT_IMAGE
	70E4	154	JNZ INT_TEST1
00A5		155	
00A7		156	; no other service is required, so the interrupt-handler
		157	; is left.
	D0E0	158	POP ACC
	D0D0	159	POP PSW
00A9	32	160	RETI
00AB		161	; end of Rx-serve-----
00AD		162	
		163	; here the array follows containing 8 destination-addresses
		164	; for up to 8 different messages to be received. The values
		165	; are fully application-specific (the values below show an
		166	; example only).
		167	RX_ARRAY_START:
	E0	168	DB 0E0H ; Rx-message #0
	00	169	DB 000H ; this message is not used
00AE		170	; ...
00AF	FA	171	DB 0FAH ; RX-message #7, containing 6 data bytes
		172	
00B0		173	END

REGISTER BANK(S) USED: 0

ASSEMBLY COMPLETE, NO ERRORS FOUND

8-bit microcontroller with on-chip CAN

P8xC592

23 PACKAGE OUTLINES

PLCC68: plastic leaded chip carrier; 68 leads

SOT188-2

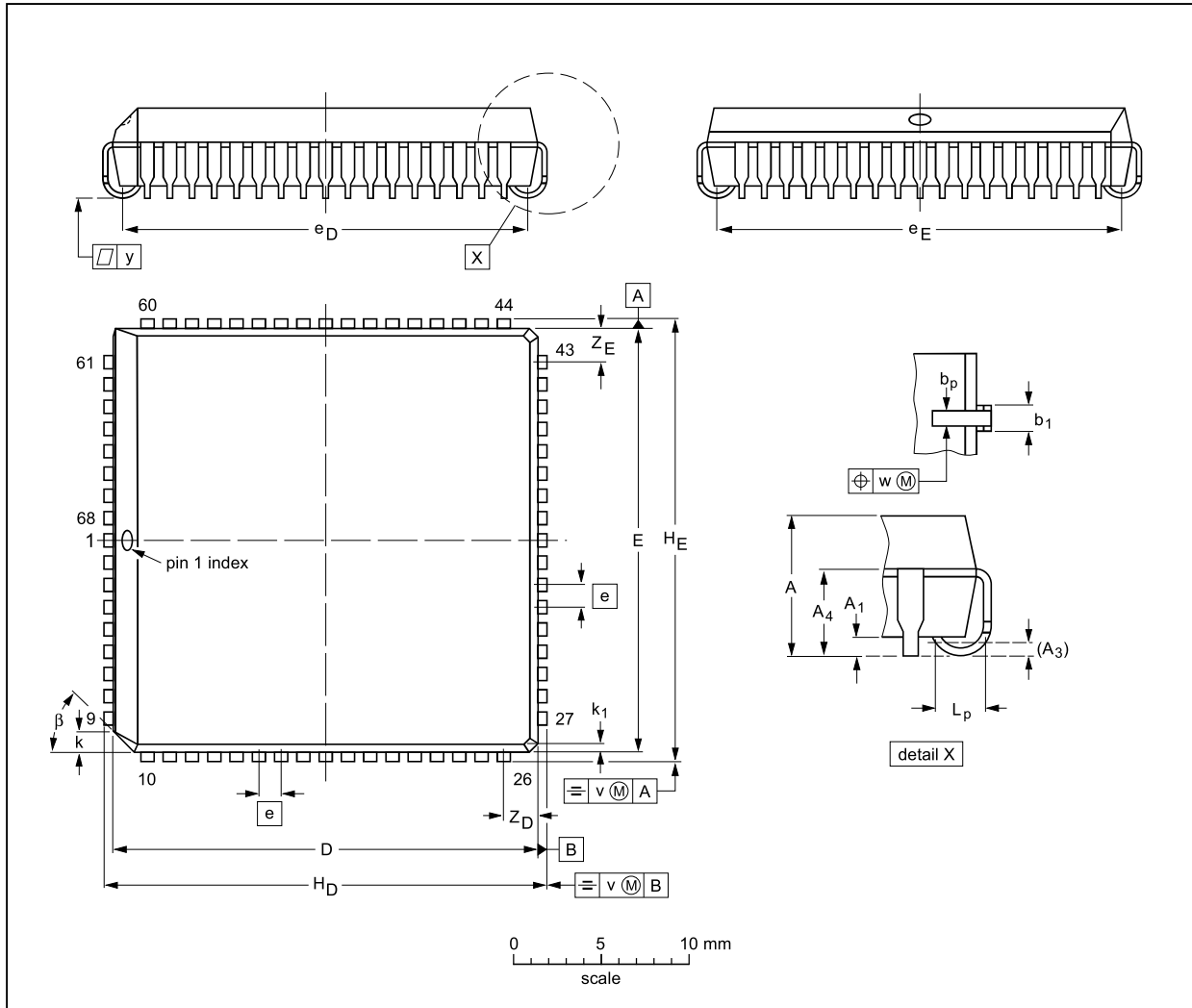

DIMENSIONS (millimetre dimensions are derived from the original inch dimensions)

UNIT	A	A <sub>1</sub> min.	A <sub>3</sub>	A <sub>4</sub> max.	b <sub>p</sub>	b <sub>1</sub>	D <sup>(1)</sup>	E <sup>(1)</sup>	e	e <sub>D</sub>	e <sub>E</sub>	H <sub>D</sub>	H <sub>E</sub>	k	k <sub>1</sub> max.	L <sub>p</sub>	v	w	y	Z <sub>D</sub> <sup>(1)</sup> max.	Z <sub>E</sub> <sup>(1)</sup> max.	β
mm	4.57 4.19	0.51	0.25	3.30	0.53 0.33	0.81 0.66	24.33 24.13	24.33 24.13	1.27	23.62 22.61	23.62 22.61	25.27 25.02	25.27 25.02	1.22 1.07	0.51	1.44 1.02	0.18	0.18	0.10	2.16	2.16	45°
inches	0.180 0.165	0.020	0.01	0.13	0.021 0.013	0.032 0.026	0.958 0.950	0.958 0.950	0.05	0.930 0.890	0.930 0.890	0.995 0.985	0.995 0.985	0.048 0.042	0.020	0.057 0.040	0.007	0.007	0.004	0.085	0.085	

Note

1. Plastic or metal protrusions of 0.01 inches maximum per side are not included.

OUTLINE VERSION	REFERENCES				EUROPEAN PROJECTION	ISSUE DATE
	IEC	JEDEC	EIAJ			
SOT188-2	112E10	MO-047AC				92-11-17 95-03-11

---

## 8-bit microcontroller with on-chip CAN

P8xC592

---

### 24 SOLDERING

#### 24.1 Introduction

There is no soldering method that is ideal for all IC packages. Wave soldering is often preferred when through-hole and surface mounted components are mixed on one printed-circuit board. However, wave soldering is not always suitable for surface mounted ICs, or for printed-circuits with high population densities. In these situations reflow soldering is often used.

This text gives a very brief insight to a complex technology. A more in-depth account of soldering ICs can be found in our *"IC Package Databook"* (order code 9398 652 90011).

#### 24.2 Reflow soldering

Reflow soldering techniques are suitable for all PLCC packages.

The choice of heating method may be influenced by larger PLCC packages (44 leads, or more). If infrared or vapour phase heating is used and the large packages are not absolutely dry (less than 0.1% moisture content by weight), vaporization of the small amount of moisture in them can cause cracking of the plastic body. For more information, refer to the Drypack chapter in our *"Quality Reference Handbook"* (order code 9397 750 00192).

Reflow soldering requires solder paste (a suspension of fine solder particles, flux and binding agent) to be applied to the printed-circuit board by screen printing, stencilling or pressure-syringe dispensing before package placement.

Several techniques exist for reflowing; for example, thermal conduction by heated belt. Dwell times vary between 50 and 300 seconds depending on heating method. Typical reflow temperatures range from 215 to 250 °C.

Preheating is necessary to dry the paste and evaporate the binding agent. Preheating duration: 45 minutes at 45 °C.

#### 24.3 Wave soldering

Wave soldering techniques can be used for all PLCC packages if the following conditions are observed:

- A double-wave (a turbulent wave with high upward pressure followed by a smooth laminar wave) soldering technique should be used.
- The longitudinal axis of the package footprint must be parallel to the solder flow.
- The package footprint must incorporate solder thieves at the downstream corners.

During placement and before soldering, the package must be fixed with a droplet of adhesive. The adhesive can be applied by screen printing, pin transfer or syringe dispensing. The package can be soldered after the adhesive is cured.

Maximum permissible solder temperature is 260 °C, and maximum duration of package immersion in solder is 10 seconds, if cooled to less than 150 °C within 6 seconds. Typical dwell time is 4 seconds at 250 °C.

A mildly-activated flux will eliminate the need for removal of corrosive residues in most applications.

#### 24.4 Repairing soldered joints

Fix the component by first soldering two diagonally-opposite end leads. Use only a low voltage soldering iron (less than 24 V) applied to the flat part of the lead. Contact time must be limited to 10 seconds at up to 300 °C. When using a dedicated tool, all other leads can be soldered in one operation within 2 to 5 seconds between 270 and 320 °C.

## 8-bit microcontroller with on-chip CAN

P8xC592

**25 DEFINITIONS**

<b>Data sheet status</b>	
Objective specification	This data sheet contains target or goal specifications for product development.
Preliminary specification	This data sheet contains preliminary data; supplementary data may be published later.
Product specification	This data sheet contains final product specifications.
<b>Limiting values</b>	
Limiting values given are in accordance with the Absolute Maximum Rating System (IEC 134). Stress above one or more of the limiting values may cause permanent damage to the device. These are stress ratings only and operation of the device at these or at any other conditions above those given in the Characteristics sections of the specification is not implied. Exposure to limiting values for extended periods may affect device reliability.	
<b>Application information</b>	
Where application information is given, it is advisory and does not form part of the specification.	

**26 LIFE SUPPORT APPLICATIONS**

These products are not designed for use in life support appliances, devices, or systems where malfunction of these products can reasonably be expected to result in personal injury. Philips customers using or selling these products for use in such applications do so at their own risk and agree to fully indemnify Philips for any damages resulting from such improper use or sale.



8-bit microcontroller with on-chip CAN

P8xC592

---

**NOTES**

8-bit microcontroller with on-chip CAN

P8xC592

---

**NOTES**

# Philips Semiconductors – a worldwide company

**Argentina:** see South America

**Australia:** 34 Waterloo Road, NORTH RYDE, NSW 2113,  
Tel. +61 2 9805 4455, Fax. +61 2 9805 4466

**Austria:** Computerstr. 6, A-1101 WIEN, P.O. Box 213,  
Tel. +43 1 60 101, Fax. +43 1 60 101 1210

**Belarus:** Hotel Minsk Business Center, Bld. 3, r. 1211, Volodarski Str. 6,  
220050 MINSK, Tel. +375 172 200 733, Fax. +375 172 200 773

**Belgium:** see The Netherlands

**Brazil:** see South America

**Bulgaria:** Philips Bulgaria Ltd., Energoproject, 15th floor,  
51 James Bourchier Blvd., 1407 SOFIA,  
Tel. +359 2 689 211, Fax. +359 2 689 102

**Canada:** PHILIPS SEMICONDUCTORS/COMPONENTS,  
Tel. +1 800 234 7381, Fax. +1 708 296 8556

**China/Hong Kong:** 501 Hong Kong Industrial Technology Centre,  
72 Tat Chee Avenue, Kowloon Tong, HONG KONG,  
Tel. +852 2319 7888, Fax. +852 2319 7700

**Colombia:** see South America

**Czech Republic:** see Austria

**Denmark:** Prags Boulevard 80, PB 1919, DK-2300 COPENHAGEN S,  
Tel. +45 32 88 2636, Fax. +45 31 57 1949

**Finland:** Sinikalliontie 3, FIN-02630 ESPOO,  
Tel. +358 615 800, Fax. +358 615 80920

**France:** 4 Rue du Port-aux-Vins, BP317, 92156 SURESNES Cedex,  
Tel. +33 1 40 99 6161, Fax. +33 1 40 99 6427

**Germany:** Hammerbrookstraße 69, D-20097 HAMBURG,  
Tel. +49 40 23 52 60, Fax. +49 40 23 536 300

**Greece:** No. 15, 25th March Street, GR 17778 TAVROS,  
Tel. +30 1 4894 339/911, Fax. +30 1 4814 240

**Hungary:** see Austria

**India:** Philips INDIA Ltd, Shivsagar Estate, A Block, Dr. Annie Besant Rd.  
Worli, MUMBAI 400 018, Tel. +91 22 4938 541, Fax. +91 22 4938 722

**Indonesia:** see Singapore

**Ireland:** Newstead, Clonskeagh, DUBLIN 14,  
Tel. +353 1 7640 000, Fax. +353 1 7640 200

**Israel:** RAPAC Electronics, 7 Kehilat Saloniki St, TEL AVIV 61180,  
Tel. +972 3 645 0444, Fax. +972 3 648 1007

**Italy:** PHILIPS SEMICONDUCTORS, Piazza IV Novembre 3,  
20124 MILANO, Tel. +39 2 6752 2531, Fax. +39 2 6752 2557

**Japan:** Philips Bldg 13-37, Kohnan 2-chome, Minato-ku, TOKYO 108,  
Tel. +81 3 3740 5130, Fax. +81 3 3740 5077

**Korea:** Philips House, 260-199 Itaewon-dong, Yongsan-ku, SEOUL,  
Tel. +82 2 709 1412, Fax. +82 2 709 1415

**Malaysia:** No. 76 Jalan Universiti, 46200 PETALING JAYA, SELANGOR,  
Tel. +60 3 750 5214, Fax. +60 3 757 4880

**Mexico:** 5900 Gateway East, Suite 200, EL PASO, TEXAS 79905,  
Tel. +1 800 234 7381, Fax. +1 708 296 8556

**Middle East:** see Italy

**Netherlands:** Postbus 90050, 5600 PB EINDHOVEN, Bldg. VB,  
Tel. +31 40 27 83749, Fax. +31 40 27 88399

**New Zealand:** 2 Wagener Place, C.P.O. Box 1041, AUCKLAND,  
Tel. +64 9 849 4160, Fax. +64 9 849 7811

**Norway:** Box 1, Manglerud 0612, OSLO,  
Tel. +47 22 74 8000, Fax. +47 22 74 8341

**Philippines:** Philips Semiconductors Philippines Inc.,  
106 Valero St. Salcedo Village, P.O. Box 2108 MCC, MAKATI,  
Metro MANILA, Tel. +63 2 816 6380, Fax. +63 2 817 3474

**Poland:** Ul. Lukiska 10, PL 04-123 WARSZAWA,  
Tel. +48 22 612 2831, Fax. +48 22 612 2327

**Portugal:** see Spain

**Romania:** see Italy

**Russia:** Philips Russia, Ul. Usatcheva 35A, 119048 MOSCOW,  
Tel. +7 095 926 5361, Fax. +7 095 564 8323

**Singapore:** Lorong 1, Toa Payoh, SINGAPORE 1231,  
Tel. +65 350 2538, Fax. +65 251 6500

**Slovakia:** see Austria

**Slovenia:** see Italy

**South Africa:** S.A. PHILIPS Pty Ltd., 195-215 Main Road Martindale,  
2092 JOHANNESBURG, P.O. Box 7430 Johannesburg 2000,  
Tel. +27 11 470 5911, Fax. +27 11 470 5494

**South America:** Rua do Rocio 220, 5th floor, Suite 51,  
04552-903 São Paulo, SÃO PAULO - SP, Brazil,  
Tel. +55 11 821 2333, Fax. +55 11 829 1849

**Spain:** Balmes 22, 08007 BARCELONA,  
Tel. +34 3 301 6312, Fax. +34 3 301 4107

**Sweden:** Kottbygatan 7, Akalla, S-16485 STOCKHOLM,  
Tel. +46 8 632 2000, Fax. +46 8 632 2745

**Switzerland:** Allmendstrasse 140, CH-8027 ZÜRICH,  
Tel. +41 1 488 2686, Fax. +41 1 481 7730

**Taiwan:** PHILIPS TAIWAN Ltd., 23-30F, 66,  
Chung Hsiao West Road, Sec. 1, P.O. Box 22978,  
TAIPEI 100, Tel. +886 2 382 4443, Fax. +886 2 382 4444

**Thailand:** PHILIPS ELECTRONICS (THAILAND) Ltd.,  
209/2 Sanpavuth-Bangna Road Prakanong, BANGKOK 10260,  
Tel. +66 2 745 4090, Fax. +66 2 398 0793

**Turkey:** Talatpasa Cad. No. 5, 80640 GÜLTEPE/ISTANBUL,  
Tel. +90 212 279 2770, Fax. +90 212 282 6707

**Ukraine:** PHILIPS UKRAINE, 2A Akademika Koroleva str., Office 165,  
252148 KIEV, Tel. +380 44 476 0297/1642, Fax. +380 44 476 6991

**United Kingdom:** Philips Semiconductors Ltd., 276 Bath Road, Hayes,  
MIDDLESEX UB3 5BX, Tel. +44 181 730 5000, Fax. +44 181 754 8421

**United States:** 811 East Arques Avenue, SUNNYVALE, CA 94088-3409,  
Tel. +1 800 234 7381, Fax. +1 708 296 8556

**Uruguay:** see South America

**Vietnam:** see Singapore

**Yugoslavia:** PHILIPS, Trg N. Pasica 5/v, 11000 BEOGRAD,  
Tel. +381 11 825 344, Fax. +381 11 635 777

**For all other countries apply to:** Philips Semiconductors, Marketing & Sales Communications,  
Building BE-p, P.O. Box 218, 5600 MD EINDHOVEN, The Netherlands, Fax. +31 40 27 24825

**Internet:** <http://www.semiconductors.philips.com/ps/>

© Philips Electronics N.V. 1996

SCA50

All rights are reserved. Reproduction in whole or in part is prohibited without the prior written consent of the copyright owner.

The information presented in this document does not form part of any quotation or contract, is believed to be accurate and reliable and may be changed without notice. No liability will be accepted by the publisher for any consequence of its use. Publication thereof does not convey nor imply any license under patent- or other industrial or intellectual property rights.

Printed in The Netherlands

617021/1200/03/pp108

Date of release: 1996 Jun 27

Document order number: 9397 750 00933

*Let's make things better.*

**Philips  
Semiconductors**



**PHILIPS**

Select & Go...

▼

▶

←

Select & Go...

▼

▶

←

Information as of 2000-08-22

## P8xC592; 8-bit microcontroller with on-chip CAN

- [Description](#)
- [Features](#)
- [Datasheet](#)
- [Blockdiagram](#)
- [Products, packages, availability and ordering](#)
- [Find similar products](#)



To be kept informed on P8xC592, subscribe to eNews.

- Catalog by Function
- Discrete semiconductors
  - Audio
  - Clocks and Watches
  - Data communications
  - Microcontrollers
  - Peripherals
  - Standard analog
  - Video
  - Wired communications
  - Wireless communications

- Catalog by System
- Automotive
  - Consumer Multimedia
  - Systems
  - Communications
  - PC/PC-peripherals

### Description

The P8xC592 is a single-chip 8-bit high-performance microcontroller with on-chip CAN-controller, derived from the 80C51 microcontroller family.

It uses the powerful 80C51 instruction set.

The P8xC592 is manufactured in an advanced CMOS process, and is designed for use in automotive and general industrial applications. In addition to the 80C51 standard features, the device provides a number of dedicated hardware functions for these applications.

Two versions of the P8xC592 will be offered:

- P80C592 (without ROM)
- P83C592 (with ROM).

Hereafter these versions will be referred to as P8xC592.

The temperature range includes (max.  $f_{CLK} = 16$  MHz):

- -40 to +85 °C version, for general applications
- -40 to +125 °C version for automotive applications.

The P8xC592 combines the functions of the P8xC552 (microcontroller) and the PCA82C200 (Philips CAN-controller) with the following enhanced features:

- 16 kbytes Program Memory
- 2 x 256 bytes Data Memory

- Relevant Links
- About catalog tree
- About search
- About this site
- Subscribe to eNews
- Catalog & Datasheets
- Search
- [P8xC592](#)
- [P8xC592](#)



- DMA between CAN Transmit/Receive Buffer and internal RAM.

The main differences between P8xC592 and P8xC552 are:

- 16 kbytes programmable ROM (P8xC552 has 8 kbytes)
- Additional 256 bytes RAM
- A CAN-controller instead of the I<sup>2</sup>C-serial interface.



[Refer to our CAN page for more information](#)

## Features

- 80C51 central processing unit (CPU)
- 16 kbytes on-chip ROM, externally expandible to 64 kbytes
- 2 x 256 bytes on-chip RAM, externally expandible to 64 kbytes
- Two standard 16-bit timers/counters
- One additional 16-bit timer/counter coupled to four capture and three compare registers
- 10-bit ADC with 8 multiplexed analog inputs
- Two 8-bit resolution Pulse Width Modulated outputs
- 15 interrupt sources with 2 priority levels (2 to 6 external interrupt sources possible)
- Five 8-bit I/O ports, plus one 8-bit input port shared with analog inputs
- CAN-controller (CAN = Controller Area Network) with DMA data transfer facility to internal RAM
- 1 Mbit/s CAN-controller with bus failure management facility
- 1/2 AVDD reference voltage
- Full-duplex UART compatible with the standard 80C51
- On-chip Watchdog Timer (WDT)
- 1.2 to 16 MHz clock frequency.

## Datasheet

Type nr.	Title	Publication release date	Datasheet status	Page count	File size (kB)	Datasheet
P8xC592	8-bit microcontroller with on-chip CAN	27-Jun-96	Product Specification	108	650	<input type="checkbox"/> <a href="#">Download</a>

## Blockdiagram



**Products, packages, availability and ordering**



<u>Partnumber</u>	<u>North American Partnumber</u>	<u>Order code (12nc)</u>	<u>marking/packing</u>	<u>package</u>	<u>device status</u>	<u>buy_online</u>
P80C592FFFA/00	P80C592FFFA	9350 865 30512	Standard Marking * Tube Dry Pack	<a href="#">SOT188</a>	Full production	<input type="text"/>
P80C592FFFA/00	P80C592FFFA-T	9350 865 30518	Standard Marking * Reel Dry Pack, SMD, 13"	<a href="#">SOT188</a>	Full production	-
P80C592FFHA/00		9350 890 10512	Standard Marking * Tube Dry Pack	<a href="#">SOT188</a>	Full production	-
P83CE598FFB/011		9350 890 10518	Standard Marking * Reel Dry Pack, SMD, 13"	<a href="#">SOT188</a>	Full production	-
P87C592EFA/02	P87C592EFAA	9352 667 95557	Standard Marking * Tray Dry Pack, Bakeable, Multiple	<a href="#">SOT318</a>	Full production	-
P87C592EFA/02	P87C592EFAA-T	9350 850 20512	Standard Marking * Tube Dry Pack	<a href="#">SOT188</a>	Full production	<input type="text"/>
P87C592EFA/A2		9350 850 20518	Standard Marking * Reel Dry Pack, SMD, 13"	<a href="#">SOT188</a>	Full production	-
		9352 104 70112	Standard Marking * Tube	<a href="#">SOT188</a>	Full production	-
		9352 104 70512	Standard Marking * Tube Dry Pack	<a href="#">SOT188</a>	Full production	-

Please read [information about some discontinued variants of this product](#).

**Find similar products:**



[P8xC592](#) links to the similar products page containing an overview of products that are similar in function or related to the part number(s) as listed on this page. The similar products page includes products from the same catalog tree(s) , relevant selection guides and products from the same functional category.

